



6060A/AN

Synthesized Signal Generator and FM Modulation Meter Combination

NSN 7Z6625012225007

The 6060A/AN combines the capabilities of one of the most successful general-purpose synthesized signal generators in the world, the Fluke 6060A, with the ability to measure FM deviation in one stand-alone unit.

The signal generator portion of this advanced unit has all of the features you would expect from Fluke's RF design engineers including frequency range from 10 kHz to 520 MHz, +13 dBm to -127 dBm output amplitude range and AM and FM modulations.

The maximum FM deviation is 500 kHz allowing the 6060A/AN to be used on many more applications than just voice communications.

The user-interactive front panel provides instant operator feedback and helps reduce entry errors. A convenient memory feature will save you time. Also included standard are IEEE-488 programmability and Reverse Power Protection. Surrounding all these capabilities is excellent RF shielding. And it is easy to service.

The FM Deviation measurement capability included in the 6060A/AN furnishes you with an effective means to measure the peak deviation (plus or minus) of a frequency modulated RF signal. Simply connect the signal of interest at the front panel connector provided for this function, then select the function and range. The result is displayed at the front panel.

The 6060A/AN is designed to fill a wide range of applications for designers, manufacturers and those who service RF equipment. It can be used as a general-purpose generator for testing land-mobile, aviation and tactical communication equipment.

The 6060A/AN comes in standard full rack width and is priced to fit your budget. Contact your local Fluke representative for a demonstration today or call 1-800-426-0361.

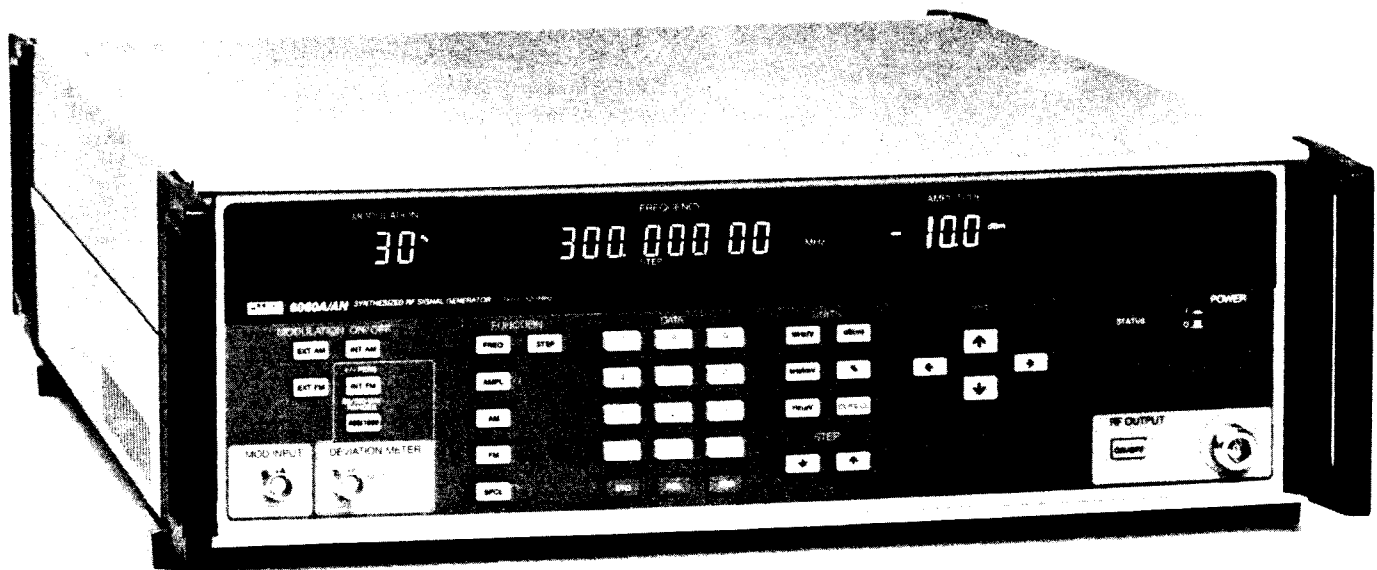



Deviation Meter:

Frequency Input:
30 MHz to 500 MHz.

Input Signal Level:
15 mV to 5V rms.

Input Impedance:
50 ohms nominal.

Measurement Ranges:
Two ranges of 500 kHz and
50.0 kHz full scale.

Polarity: Selectable \pm peak.

Modulation Rate: 100 Hz to 8 kHz.

Accuracy: $\pm 6\%$ of full-scale range from 100 Hz to 8 kHz.

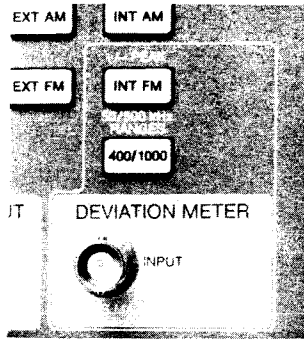

General:

Temperature:

Operating: 0°C to 50°C (32°F to 122°F)
Non-operating: -40°C to 70°C (-40°F to 158°F)

Humidity Range:

Operating: 0-95% non-condensing.

Vibration:

Non-operating: 5 Hz to 15 Hz at 0.06 in, 15 Hz to 25 Hz
at 0.04 in, and 25 Hz to 55 Hz at 0.02 in. DA.

Shock:

Non-operating: Bench handling per MIL-T-28800C
Class 5, Style E.

Electromagnetic Compatibility: The radiated emissions induce $< 1 \mu\text{V}$ of the Generator's output signal into a 1-inch diameter, two-turn loop, 1 inch from any surface as measured into a 50-ohm receiver.

Also complies with the following standards:

CE03 of MIL-STD-461B (Power and interconnecting leads), 0.015 MHz to 50 MHz

RE02 of MIL-STD-461B (14 kHz to 10 GHz)

FCC Part 15 (j), class A

CISPR 11

Reverse Power Protection Level: Up to 50 watts from a 50-ohm source, 0.01 MHz to 520 MHz. Will withstand up to 25V dc. Protection not provided when instrument is off.

IEEE-488 Interface Functions (IEEE Std 488-1978):

SH1, AH1, T5, TE0, L3, LE0, SR1, RL1, PP0, DC1, DT1, C0, and E1.

Size:	Width	Height	Depth
	43 cm	13.3 cm	55.3 cm
	17 in	5.25 in	21.8 in

Power: 115V, 230V ac $\pm 10\%$, 47 Hz to 400 Hz, < 100 watts.

Weight: < 18.2 kg (40 lbs).

Calibration Interval: After calibration, the equipment shall meet each performance requirement within the tolerance specified for a period of 9 months.

Supplemental Characteristics:

The following characteristics are provided to assist in the application of the instrument and to describe the typical performance that can be expected.

Frequency Switching Speed: < 150 ms to be within 100 Hz of final frequency.

Amplitude Switching Speed: < 100 ms to be within 0.1 dB of final amplitude.

Amplitude Range: Programmable to +19 dBm and -147.4 dBm, usable to +15 dBm. Fixed-Range, selected by Special Function, allows for more than 12 dB of vernier without switching the attenuator.

AM Accuracy: $\pm (2\% + 4\%$ of setting) for internal rates, for depths 90% or less and peak amplitude of +13 dBm or less.

AM Distortion: $< 1.5\%$ THD to 30% AM, $< 3\%$ to 70% AM, $< 5\%$ to 90% AM at internal rates.

Incidental FM: $< 0.3f_m$ for internal rates and 30% AM.

FM Accuracy: $\pm 7\%$ for rates from 0.3 to 20 kHz > 1 kHz deviation $f_o > 0.4$ MHz.

FM Distortion: $< 1\%$ THD for rates of 0.3 kHz to 20 kHz, 1 kHz to 99.9 kHz deviation for $f_o > 5$ MHz.

Incidental AM: $< 1\%$ AM at 1 kHz rate, for the maximum deviation or 50 kHz, whichever is less.

Residual FM (rms in 0.3-kHz to 3-kHz Band): < 15 Hz from 245 to 520 MHz; < 30 Hz elsewhere.

Residual FM (rms in 0.05-kHz to 15-kHz Band): < 30 Hz from 245 to 520 MHz; < 60 Hz elsewhere.

Noise (at 20 kHz offset): < -113 dBc/Hz (except < -107 dBc/Hz below 245 MHz).

Spurious: < -60 dBc for offsets greater than 10 kHz.

Fixed frequency spurs are < -60 dBc or < -140 dBm, whichever is larger.

External Modulation: Annunciators indicate when a 1V peak signal is applied, $\pm 2\%$, over a 0.02-kHz to 100-kHz band.

Deviation Meter Accuracy: $\pm 5\%$ of reading ± 1 count for rates between 100 Hz and 10 kHz.

IEEE-488 Interface: All controls except the power switch and the internal/external reference switch are remotely programmable via IEEE Std 488-1978. All status including option compliment are available remotely. The Store/Recall memory data may be transferred via an external controller. In talk only, the appropriate commands are generated when the front panel step-up and step-down entries are made to control another 6060A/AN, 6060B, 6070A, or 6071A. (The 6070 and 6071A only have FREQUENCY STEP.)



CERTIFICATE of CALIBRATION

MODEL 6060A/AN
SERIAL NO. 4205107
DATE 3/13/87

John Fluke Mfg. Co., Inc. certifies that this instrument has been calibrated at an ambient temperature of $23^{\circ}\text{C} \pm 5^{\circ}\text{C}$ using standards and instruments which are traceable to the National Bureau of Standards, or to nationally accepted measuring systems. The standards and instruments used in the calibration are supported by a calibration system which meets or exceeds the requirements of MIL-STD-45662A. The reference standards which support this calibration system are calibrated on a schedule which is adjusted to maintain traceability at the required accuracy level. NBS Test Report numbers are listed below:

DC Resistance	236930	AC Voltage	237685
DC Voltage	236962	RF Power	810375
AC Capacitance	234735	RF Voltage	809880
AC Current	236133	Temperature	237019
AC Inductance	236930		

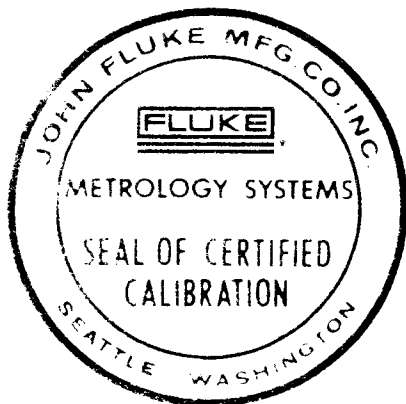

Les Huntley
Les Huntley
Metrology Assurance Manager

Ronald R Valentine
Ron Valentine
Product Assurance Manager,
Instrumentation Division

CHANGE/ERRATA INFORMATION

ISSUE NO: 11 1/87

This change/errata contains information necessary to ensure the accuracy of the following manual. Enter the corrections in the manual if either one of the following conditions exist:

1. The revision letter stamped on the indicated PCB is equal to or higher than that given with each change.
2. No revision letter is indicated at the beginning of the change/errata.

MANUAL

Title: 6060A/AN
Print Date: April 1985
Rev.- Date: 1 - 1/86

C/E PAGE EFFECTIVITY

Page No.	Print Date
1	5/86
2	5/86
3	5/86
4	5/86
5	5/86
6	5/86
7	5/86
8	5/86
9	5/86
10	1/87
11	1/87
12	1/87
13	1/87

ERRATA #6

On pages 5-13 through 5-15, Table 5-6, make the following changes:

CHANGE:	C29,38,201,202	4
TO:	C29,38,,202	3
CHANGE:	C30,37,49,118	4
TO:	C30,37,49	3
CHANGE:	C51,113,114	3
TO:	C51,113,114,118	4
DELETE:	C171	
CHANGE:	C197,219,227,240	4
TO:	C197,219,227	3
ADD:	C201	CAP CER,68PK +-2%,100V 362756 89536 362756	1
CHANGE:	R2,159,201,209	4
TO:	R2,38,159,201,209	5
CHANGE:	R7,44,94,148,152,154,169,170	8
TO:	R7,44,94,152,154,169,170	7
CHANGE:	R75	RES,MF,1.91K,+/-1%,0.125W,100PPM 236877 89536 236877	1
TO:	R75	RES,MF,3.09K,+/-1%,0.125W,100PPM 235150 89536 235150	1
CHANGE:	R76,85	2
TO:	R76,85,91	3
CHANGE:	R89	RES,MF,6.49K,+/-1%,0.125W,100PPM 294900 91637 CMF556491F	1
TO:	R89	RES,MR,3.92K,+/-1%,0.125W,100PPM 249801 89536 249801	1
DELETE:	R91	
CHANGE:	R146,150	
TO:	R148,150	

On page 5-17, replace Figure 5-6, with Figure 8-6 found on page 8-10.

On page 8-14, Figure 8-6, change the value of C201,

FROM:	47PF
TO:	68PF

ERRATA #7

On page 5-23, replace Figure 5-8, with Figure 8-8 found on page 8-16.

ERRATA #9

On page 5-34, Table 5-16, make the following deletions:

DELETE: XU2,3,5|.....

DELETE: XU4,7|.....

ERRATA #10

On page 5-13, Table 5-6,

CHANGE: C154|CAP, CER 1.8PF|512897|89536|512897|1

TO: C154|CAP, CER 6.8PF|512327|89536|512327|1

On page 8-13, Figure 8-6, change flag note 11 to read:

FACTORY SELECTED COMPONENT. SELECT VALUE BETWEEN 6.8 pf AND 22.0 pf.

CHANGE #2 - 25136

Rev.-G, A2A1 Synthesizer PCA (6060A/AN-4019)

On page 5-13, Table 5-6,

CHANGE: C54,71,91,127,166|CAP, TA, 10UF, +-20%, 10V|176214|.....|5

TO: C71,91,127,166|CAP, TA, 10UF, +-20%, 10V|176214|.....|4

CHANGE: C58,82,107,150|CAP, TA, 39UF, +-20%, 6V|163915|.....|4

TO: C54,58,82,107,150|CAP, TA, 39UF, +-20%, 6V|163915|.....|5

On page 8-11, Figure 8-6, in the lower left, change the value of C54,

FROM: 10/10V

TO: 39/6V

CHANGE #3 - 25481

Rev.-H, A2A1 Synthesizer PCA (6060A/AN-4019)

On page 5-14, Table 5-6, change the FLUKE STOCK NUMBER for Q10,13,14,

FROM: 477729

TO: 783308

On page 8-13, Figure 8-6, change Q10, Q13 and Q14,

FROM: SD213

TO: SD215

CHANGE #4 - 25482

Rev.-J, A2A1 Synthesizer PCA (6060A/AN-4019)

On page 5-15, Table 5-6, change the FLUKE STOCK NUMBER for U27,29,

FROM: 507566

TO: 802280

CHANGE #6 - 25483

Rev.-E, A2A4 Output PCA (6060A/AN-4024)

On page 5-22, Table 5-8, make the following changes:

Change the FLUKE STOCK NO. for U303,

FROM: 722264

TO: 802298

Change the FLUKE STOCK NO. for U403,

FROM: 507566

TO: 802280

CHANGE 7# - 25561

Rev.-F, A2A4 Output PCA (6060A/AN-4024)

On page 5-20, Table 5-8,

ADD: L117 | FERRITE BEAD | 321182 | 89536 | 321182 | 1

On pages 5-23 and 8-16, Figures 5-8 and 8-8, add L117 as shown in Figure 5.

On page 8-17, Figure 8-8, add L117 as shown in Figure 6.

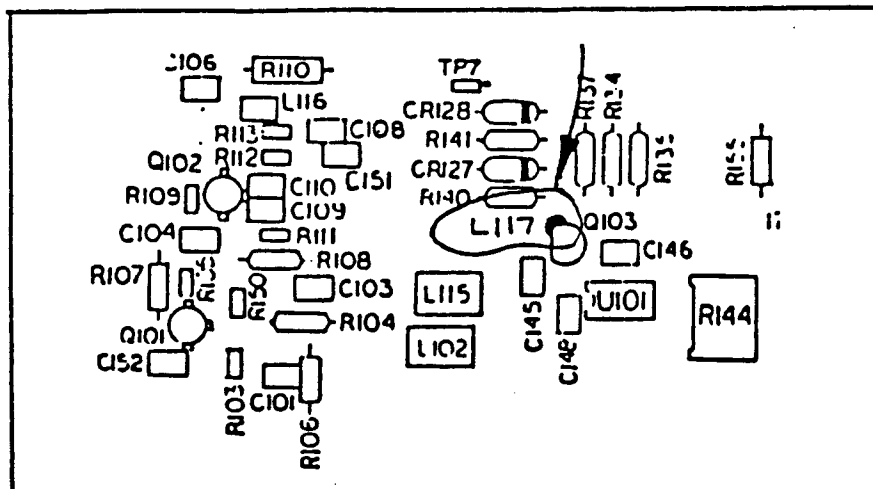

Figure 5.

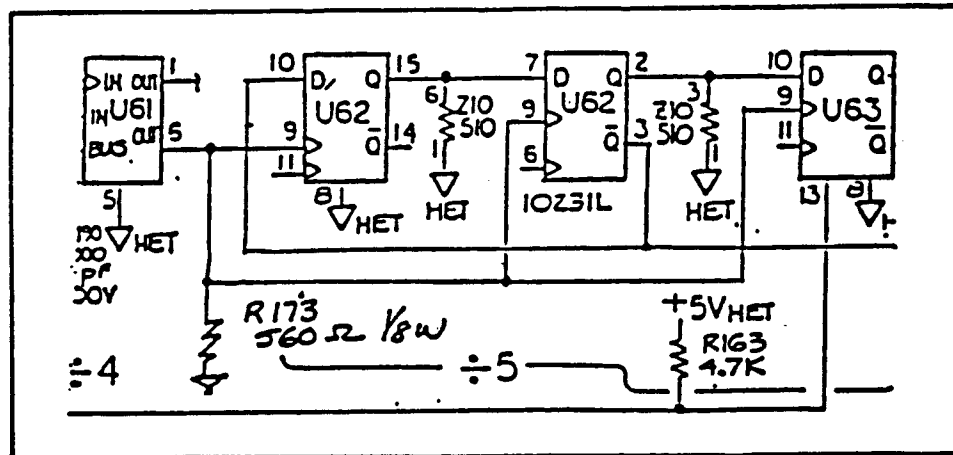

Figure 8.

CHANGE #9 - 25586

Rev.-L, A2A1 Synthesizer PCA (6060A/AN-4019)

On page 5-15, Table 5-6, make the following changes:

DELETE: R106 |.....

CHANGE: R151 |RES, CF, 2.2K, +/-5%, 0.25W|343400|80031|CR251-4-5P2K2|1
 TO: R106, 151|RES, CF, 2.2K, +/-5%, 0.25W|343400|80031|CR251-4-5P2K2|2

On page 8-13, Figure 8-6, change the value of R106,

FROM: 2.0K
 TO: 2.2K

CHANGE #10 - 25640

Rev.-G, A2A4 Output PCA (6060A/AN-4024)

On pages 5-22 and 5-23, Table 5-8, make the following changes:

CHANGE: R262, 424 |..... |2
 TO: R262 |..... |1

ADD: R424 |RES, CF, 110, +/-5%, 0/125W|740076|89536|740076|1

On page 8-18, Figure 8-8, change the value of R424,

FROM: 160Q
 TO: 110Q

CHANGE #15 - 25974

Rev.-D, A4A1 Discriminator PCA (6060A/AN-4061)

On page 5-34, Table 5-16,

CHANGE: H1|WASHER, SPRING, COPPER, 0.316 ID|544239|89536|544239|1
 TO: H1|WASHER, RELAY |803247|89536|803247|1

CHANGE #16 - 26115

Rev.-M, A2A2 VCO PCA (6060A-4018)

On page 5-18, Table 5-7, make the following changes:

CHANGE: R5, 11|RES, CF, 5.6, +/-5%, 0.25W|441618|80031|CR251-4-5P5R6|2
 TO: R5 |RES, CF, 8.2, +/-5%, 0.25W|442269|80031|CR251-4-5P8R2|1

ADD: R11 |RES, CF, 15, +/-5%, 0.25W|348755|80031|CR251-4-5P15E|1

On page 8-15, Figure 8-7, change the values of R5 and R11 respectively,

FROM: 5.6 and 5.6
 TO: 8.2 and 15

ERRATA #12

On pages 4D-2 and 4D-3, make the following changes:

Replace the paragraph preceeding 4D-3, with:

To order a replacement module, use the part number shown in Table 4D-1 and specify a Module Exchange part. The following paragraphs describe the available exchange modules and how to adjust the Generator, if necessary after installation. For removal instructions refer to Section 4B Access Procedures.

In Table 4D-1, delete the following:

A1A2 Switch PCA (P/N 738591)

In the first paragraph following 4D-5, change the second sentence to read:

This EPROM replaces the old one installed on the Controller PCA, A2A7 (U23).

Replace the second paragraph following 4D-5, with:

NOTE

A plug-in coupling capacitor is used to interconnect the VCO and the Output PCAs, thus eliminating the need for a soldering iron when replacing this assembly.

CHANGE #17 - 26233

Rev.-P, A2A1 Synthesizer PCA (6060A/AN-4019)

On page 5-16, Table 5-6,

CHANGE: XU26,30-32,38|SOCKET, IC, 20 PIN|454421|09922|DILB20P-108|5
 TO: XU38 |SOCKET, IC, 20 PIN|454421|09922|DILB20P-108|1

CHANGE #18 - 26234

On page 5-9, Table 5-4, change the FLUKE STOCK NO. and MANUFACTURERS PART NUMBER for H28,

FROM: 772376
 TO: 800441

CHANGE #19 - 26477

Rev.-E, A4A1 Discriminator PCA (6060A/AN-4061)

On page 5-34, Table 5-16,

CHANGE: L5,6|INDUCTOR,0.47UH,+/-10%,264MHZ,SHLDED|320929|24759|MRO.47|1
 TO: L5,6|INDUCTOR,0.47UH,+/-10%,264MHZ,SHLDED|329664|89536|329664|1

CHANGE #20 - 26572

Rev.-T, A2A1 Synthesizer PCA (6060A/AN-4019)

On page 5-15, Table 5-6,

CHANGE: R84|RES,MF,3.01K,+/-1%,0.125W,100PPM|312645|91637|CMF553011F|1
 TO: R84|RES,MF,4.02K,+/-1%,0.125W,100PPM|235325|91637|CMF554021F|1

On page 8-13, Figure 8-6, change the value of R84,

FROM: 3.01K
 TO: 4.02K

CHANGE #21 - 26930

Rev.-B, A2A7 Controller PCA (6060A/AN-4028)

On page 5-27, Table 5-12, make the following changes:

CHANGE: U5,44|IC,LSTTL,HEX INVERTER|393058|01295|SN74LS04N|2
 TO: U5 |IC,LSTTL,HEX INVERTER|393058|01295|SN74LS04N|1

ADD: U44|IC,LSTTL,HEX INVERTER W/SCHMT TRIG|483180|01295|SN74LS14N|1

On page 8-25, Figure 8-11, add two gates to the microprocessor reset circuit as shown in Figure 10 and change U44,

FROM: 74LS04
 TO: 74LS14

Customer Reply Form

INSTRUMENT

Model Number: 6060A/AN Serial Number: 4205107 Date Received: _____

Thank you for the purchase of the 6060A. In an effort to sustain our highest quality standards please fill out this reply form. We are anxious to review your comments.

Workmanship

Are there any surface areas which reflect damage or poor quality workmanship? (Circle one) Yes / No

If Yes, please provide details: _____

Performance

Does the instrument perform to manual specifications in your applications? (Circle one) Yes / No

If No, please provide details: _____

Documentation

(fold here)

Do the operating instructions help you use the instrument? (Circle one) Yes / No

If No, please provide details: _____

Application

For what primary use was your instrument ordered?

_____ R&D _____ Production Test
_____ Service _____ Other: _____

What products are manufactured or services provided at this location? _____

Name _____ Title _____

Address _____

Phone _____ Mail Stop _____

If you are dissatisfied with your instrument or accompanying material, please call **Customer Sales Support 1-800-742-4678** for immediate attention.

Form No. G708 10/85

Supervisor



6060A/AN

SYNTHESIZED RF SIGNAL GENERATOR

Instruction Manual

P/N 755421

April 1985 Rev 1 1/86

©1986 John Fluke Mfg. Co., Inc. All rights reserved. Litho in U.S.A.



Table of Contents

SECTION	TITLE	PAGE
1	INTRODUCTION AND SPECIFICATIONS	1-1
1-1.	INTRODUCTION	1-1
1-2.	UNPACKING THE GENERATOR	1-1
1-3.	SAFETY	1-1
1-4.	GENERATOR DESCRIPTION	1-2
1-5.	Controller Functions	1-2
1-9.	Frequency	1-3
1-10.	Reference	1-3
1-11.	Amplitude	1-3
1-12.	Modulation	1-3
1-13.	Deviation Meter	1-3
1-14.	OPTIONS AND ACCESSORIES	1-4
1-15.	RECOMMENDED TEST EQUIPMENT	1-4
1-16.	MNEMONICS	1-4
1-17.	SIGNAL GENERATOR SPECIFICATIONS	1-4
2	INSTALLATION AND OPERATION	2-1
2-1.	INTRODUCTION	2-1
2-2.	INITIAL INSPECTION	2-1
2-3.	SETTING UP THE GENERATOR	2-1
2-4.	Line Power Requirements	2-1
2-5.	Line Voltage and Fuse Selection	2-1
2-6.	IEEE-488 Address	2-2
2-7.	RACK OR BENCH MOUNTING THE GENERATOR	2-2
2-8.	GENERAL OPERATING INFORMATION	2-3
2-9.	Familiarization	2-3
2-10.	Generator Versus Meter Mode Operation	2-3
2-11.	Local Versus Remote Operation	2-3
2-12.	Power-On Sequence	2-3
2-13.	Changing Output Parameters	2-9
2-14.	Function Entry	2-9
2-15.	Bright-Digit Edit Operation	2-10
2-16.	Step Operation	2-12
2-17.	Status and Clear Entries	2-12
2-18.	RF Output On/Off	2-13
2-19.	Modulation On/Off and Rate	2-13

SECTION	TITLE	PAGE
2-20.	Deviation Meter	2-13
2-20.	Memory	2-13
2-22.	Special Function	2-14
2-23.	OPERATING REFERENCE MATERIAL	2-15
2-24.	Amplitude and Frequency Entry	2-15
2-25.	Amplitude Fixed Range	2-16
2-26.	Amplitude Units Conversion	2-17
2-27.	Bright-Digit Edit Entry	2-18
2-28.	Deviation Meter Entry	2-20
2-29.	Memory Entry	2-21
2-30.	Modulation Entry	2-23
2-31.	Relative Function	2-24
2-32.	RF Output On/Off Entry	2-26
2-33.	Special Function Entry	2-26
2-34.	Status and Clear Entry	2-27
2-35.	Step Entry	2-28
2-36.	REMOTE OPERATION (IEEE-488 INTERFACE)	2-29
2-37.	Setting Up The IEEE-488 Interface	2-30
2-38.	Programming Commands	2-31
2-39.	Programming Examples	2-38
2-43.	Interface Functions	2-41
2-44.	Address Mode	2-41
2-49.	Talk-Only Mode	2-44
2-50.	Listen-Only Mode	2-45
2-51.	Command Syntax	2-45
2-55.	Command Descriptions	2-47
2-63.	Command Processing	2-63
2-66.	Timing Data	2-64
2-72.	Power-on Conditions	2-66
3	THEORY OF OPERATION	3-1
3-1.	INTRODUCTION	3-1
3-2.	GENERAL DESCRIPTION	3-1
3-3.	Front Section	3-1
3-4.	Module Section	3-1
3-5.	Rear Section	3-1
3-6.	Deviation Meter Section	3-2
3-7.	FUNCTIONAL DESCRIPTION	3-2
3-8.	Level	3-2
3-9.	Amplitude Modulation	3-2
3-10.	Frequency	3-3
3-11.	Frequency Modulation	3-3
3-12.	Deviation Meter	3-3
3-13.	SOFTWARE OPERATION	3-4
3-14.	User Interface	3-4
3-15.	Amplitude Control	3-4
3-16.	Attenuators	3-4
3-17.	Level DAC	3-5
3-18.	Temperature Compensation	3-5
3-19.	Reverse Power Protector Option	3-5
3-20.	Frequency Reference Control	3-5

SECTION	TITLE	PAGE
4B-3.	ACCESS INSTRUCTIONS	4B-1
4B-4.	Removing the Front Section Assembly, A1	4B-1
4B-5.	Removing the Rear Section Assembly, A3	4B-2
4B-6.	Removing the Synthesizer Board, A2A1	4B-2
4B-7.	Removing the Output Board, A2A4	4B-2
4B-8.	Removing the Synthesizer Board A2A1	4B-2
4B-9.	OUTPUT LEAKAGE TEST	4B-3
4B-10.	Removing the Controller Board, A2A7	4B-3
4B-11.	Removing the Meter Module Assembly, A4	4B-3
4B-12.	Removing the Discriminator Board, A4A2	4B-3
4B-13.	Removing the A/D Board, A4A2	4B-3
4C	CALIBRATION ADJUSTMENTS	4C-1
4C-1.	INTRODUCTION	4C-1
4C-2.	SAFETY	4C-1
4C-3.	POWER SUPPLY, A3A1, ADJUSTMENT	4C-1
4C-4.	DISPLAY ASSEMBLY, A1A1, ADJUSTMENT PROCEDURE ..	4C-2
4C-5.	OUTPUT ASSEMBLY, A2A4, ADJUSTMENT	4C-4
4C-6.	SYNTHESIZER ASSEMBLY, A2A1 ADJUSTMENT	4C-10
4C-7.	Deviation Meter Assembly, A4A1 Adjustment	4C-16
4D	TROUBLESHOOTING AND REPAIR	4D-1
4D-1.	INTRODUCTION	4D-1
4D-2.	MODULE REPLACEMENT	4D-1
4C-3.	Power Supply PCA, A3A1	4D-2
4D-4.	Synthesizer PCA, A2A1	4D-2
4D-5.	VCO PCA, A2A2	4D-3
4D-6.	Output PCA, A2A4	4D-3
4D-7.	Controller PCA, A2A7	4D-3
4D-8.	Display PCA, A1A1	4D-3
4D-9.	Attenuator Attenuator/RPP PCA (A2A5)	4D-3
4D-10.	IEEE-488 PCA, A3A3	4D-3
4D-11.	Discriminator PCA, A4A1	4D-3
4D-12.	A/D PCA, A4A2	4D-3
4D-13.	PARTS REPLACEMENT	4D-4
4D-14.	TROUBLESHOOTING	4D-4
4D-15.	Service Special Functions	4D-4
4D-16.	UNCAL Conditions	4D-5
4D-17.	Self Test Description	4D-5
4D-22.	Check Output Signal	4D-8
4D-23.	Check Power Supply Voltages	4D-9
4D-24.	DIGITAL AND CONTROL TROUBLESHOOTING	4D-9
4D-25.	Control Activity	4D-10
4D-26.	Latch Control	4D-10
4D-27.	Microprocessor Kernel	4D-10
4D-28.	Power Reset	4D-10
4D-29.	Microprocessor Inputs	4D-10
4D-30.	IEEE-488 Interrupt	4D-11
4D-31.	Microprocessor Bus	4D-11

SECTION	TITLE	PAGE
3-21.	Frequency Control	3-5
3-22.	Modulation On/Off	3-5
3-23.	Modulation Frequency	3-6
3-24.	Amplitude Modulation	3-6
3-25.	Frequency Modulation	3-6
3-26.	FM Deviation	3-6
3-27.	Deviation Meter	3-6
3-28.	Self Test	3-6
3-29.	Service Special Functions	3-8
3-30.	Status Signals	3-8
3-31.	DETAILED CIRCUIT DESCRIPTIONS	3-8
3-32.	FRONT SECTION, A1	3-9
3-33.	Display PCA, A1A1	3-9
3-40.	Switch PCB, A1A2	3-10
3-41.	MODULE SECTION, A1	3-10
3-42.	Synthesizer PCA, A2A1	3-10
3-53.	VCO PCA, A2A2	3-19
3-54.	Output PCA, A2A4	3-20
3-60.	Attenuator/RPP PCA, A2A5	3-22
3-61.	Controller PCA, A2A7	3-24
3-70.	REAR SECTION, A3	3-26
3-71.	Power Supply PCA, A3A1	3-26
4	MAINTENANCE	4-1
4-1.	INTRODUCTION	4-1
4-2.	SERVICE METHODS	4-1
4-3.	Fluke Service	4-1
4-4.	Module Replacement	4-1
4-5.	Parts Replacement	4-1
4A	PERFORMANCE TESTS	4A-1
4A-1.	INTRODUCTION	4A-1
4A-2.	TEST EQUIPMENT	4A-1
4A-3.	POWER-ON TEST	4A-3
4A-4.	SYNTHESIS TEST	4A-3
4A-5.	HIGH-LEVEL ACCURACY TEST	4A-4
4A-6.	MID-LEVEL ACCURACY TEST	4A-6
4A-7.	LOW-LEVEL TEST	4A-7
4A-8.	ALTERNATE-LEVEL ACCURACY TEST	4A-8
4A-9.	OUTPUT LEAKAGE TEST	4A-9
4A-10.	ALTERNATE OUTPUT LEAKAGE TEST	4A-10
4A-11.	SWR TESTS	4A-11
4A-12.	HARMONIC AND SPURIOUS TEST	4A-12
4A-13.	MODULATION TESTS	4A-13
4A-14.	DEVIATION METER TEST	4A-17
4B	ACCESS PROCEDURES	4B-1
4B-1.	INTRODUCTION	4B-1
4B-2.	LOCATION OF MAJOR ASSEMBLIES	4B-1

SECTION	TITLE	PAGE
4D-32.	Address Decoder	4D-11
4D-33.	Display and Controls	4D-11
4D-34.	SYNTHESIZER TROUBLESHOOTING	4D-11
4D-35.	Reference Circuitry Check	4D-14
4D-36.	Main Phase Lock Loop	4D-14
4D-37.	Sub-Synthesizer and HET (800 MHz), 40-MHz Loop	4D-15
4D-38.	FM Circuitry	4D-16
4D-39.	LEVEL TROUBLESHOOTING	4D-16
4D-40.	OUTPUT ASSEMBLY TEST POINT SIGNAL INFORMATION	4D-16
4D-41.	ATTENUATOR/RPP LEVEL CONTROL	4D-17
4D-42.	Attenuator Check	4D-17
4D-43.	Unleveled Condition	4D-19
4D-44.	RPP Check	4D-19
4D-45.	AM TROUBLESHOOTING	4D-19
4D-46.	Internal/External AM	4D-19
4D-47.	ALC Loop Control Voltage	4D-20
4D-48.	Detector Linearity	4D-21
4D-49.	DEVIATION METER TROUBLESHOOTING	4D-21
4D-50.	A/D	4D-21
4D-51.	Discriminator	4D-22
5	LIST OF REPLACEABLE PARTS	5-1
	TABLE OF CONTENTS	5-1
	5-1. INTRODUCTION	5-2
	5-2. Parts List Information	5-2
	5-3. HOW TO OBTAIN PARTS	5-2
	5-4. Recommended Spare Parts Kit	5-3
6	OPTIONS	6-1
	TABLE OF CONTENTS	6-1
7	GENERAL INFORMATION	7-1
	7-1. FEDERAL SUPPLY CODES FOR MANUFACTURERS	7-2
	7-2. U.S. SALES AREAS FOR ALL FLUKE PRODUCTS	7-3
	7-3. INTERNATIONAL SALES OFFICES	7-5
	7-4. TECHNICAL SERVICE CENTERS	7-6
7A	MANUAL CHANGE INFORMATION	7A-1
8	SCHEMATIC DIAGRAMS	8-1
	TABLE OF CONTENTS	8-1

List of Tables

TABLE	TITLE	PAGE
1-i.	Signal Generator Specifications	1-5
2-1.	Front Panel Controls, Indicators, and Connectors	2-5
2-2.	Rear Panel Controls, Connectors, and Switches	2-11
2-3.	Instrument Preset State	2-12
2-4.	Special Functions	2-14
2-5.	UNCAL Error Codes	2-27
2-6.	REJect ENTRY Codes	2-28
2-7.	Index of IEEE-488 Commands	2-31
2-8.	IEEE-488 Commands	2-32
2-9.	IEEE-488 Interface Functions List	2-41
2-10.	IEEE-488 Address Mode Message Descriptions	2-42
2-11.	Suffix Types	2-48
2-12.	Learn Character to Hexadecimal Conversion	2-56
2-13.	Interface Mode Commands	2-57
2-14.	Self-Test Error Codes	2-59
2-15.	Input/Output Monitor Commands	2-60
2-16.	Read/Write Monitor Commands	2-61
2-17.	Hardware Control Monitor Commands	2-61
2-18.	SRQ Mask and Status Values	2-63
2-19.	Command-Parsing Time	2-65
2-20.	Typical Programming Time of the Generator Functions	2-65
2-21.	IEEE-488 Power-On State	2-66
3-1.	Power Supply Rectifier Configuration	3-27
4A-1.	Recommended Test Equipment	4A-2
4A-2.	Modulation Tests Requirements	4A-13
4A-3.	AM Test Conditions	4A-15
4A-4.	AM Depth Range	4A-15
4D-1.	Module Exchange Assemblies	4D-2
4D-2.	Self Test Display Field	4D-6
4D-3.	AAA Field AM and FM Tests	4D-6
4D-4.	BBB Field Test Results	4D-7
4D-5.	CCC Field Test Results	4D-7
4D-6.	DDD Field Test Results	4D-7
4D-7.	Band, Filter, and Frequency Programming Data	4D-8
4D-8.	Power Supply Characteristics	4D-9
4D-9.	Address Codes for the Front Panel Keys	4D-12
4D-10.	Synthesizer PCA Test Points	4A-13
4D-11.	Frequency Reference Control	4D-14
4D-12.	FM Range	4D-16

LIST OF TABLES, *continued*

TABLE	TITLE	PAGE
4D-13.	FM DAC Control	4D-16
4D-14.	Output PCA Test Points	4D-17
4D-15.	Attenuator Level Control	4D-18
4D-16.	Attenuator Levels	4D-18
4D-17.	Modulation On/Off Control	4D-20
4D-18.	Modulation Frequency Control	4D-20
4D-19.	Deviation Meter Control	4D-22

List of Illustrations

FIGURE	TITLE	PAGE
Frontispiece	6060A/AN Signal Generator	x
2-1.	Fuse/Filter/Line Voltage Selection Assembly	2-2
2-2.	6060A/AN Outside Dimensions	2-4
2-3.	Front Panel Controls, Indicators, and Connectors	2-5
2-4.	Rear Panel Controls, Connectors, and Switches	2-11
2-5.	6060A/AN Signal Generator Connected to a 1722A	2-31
2-6.	6060A/AN IEEE-488 Bus Connected to a 6060A IEEE-488 Bus	2-45
2-7.	Learn String Example	2-51
3-1.	Triple-Modulus Prescaler Operation	3-13
3-2.	N-Divider Operation	3-14
3-3.	N-Divider Timing Diagram	3-15
4A-1.	Two-Turn Loop	4A-1
4A-2.	High-Level Accuracy Test Conditions	4A-5
4A-3.	High-Level Accuracy Test Conditions	4A-6
4C-1.	Power Supply Test Points	4C-3
4C-2.	Module Plate, Bottom View	4C-5
4C-3.	Module Plate, Top View	4C-12
4C-4.	Deviation Meter Module, Top View	4C-16

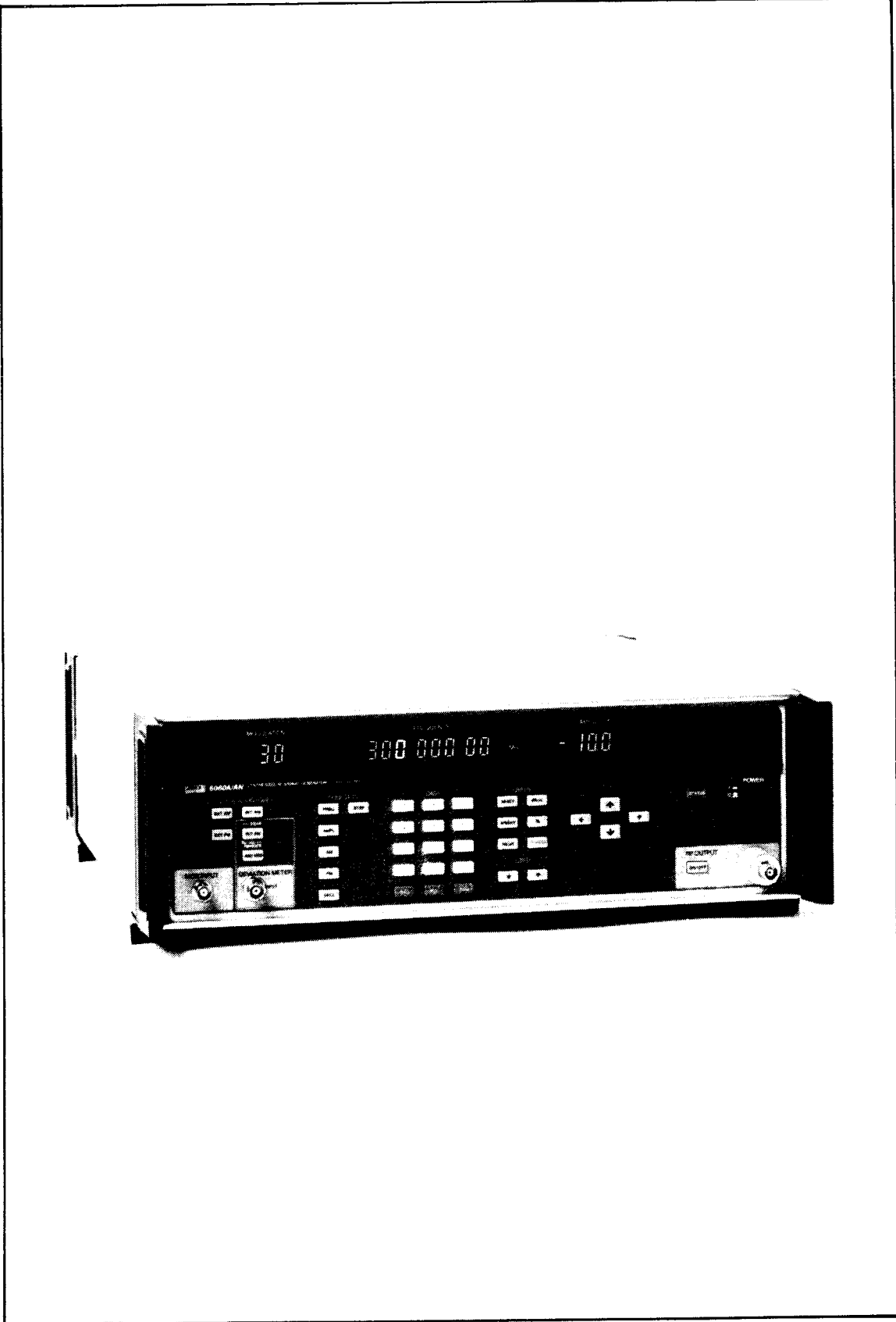

6060A/AN Synthesized Signal Generator

Section 1

Introduction and Specifications

1-1. INTRODUCTION

The 6060A/AN Synthesized Signal Generator (referred to as the Generator or instrument) is a fully-programmable, precision, synthesized signal generator. In addition, an FM deviation meter is included. The Generator is designed for applications that require good modulation, frequency accuracy, and output level performance with moderate spectral purity. It is well suited for testing a wide variety of RF components and systems including filters, amplifiers, mixers, and radios, particularly on-channel radio testing.

1-2. UNPACKING THE GENERATOR

This shipping container should include a 6060A/AN Signal Generator, two Instruction Manuals, and a line power cord. Any accessories ordered for the Generator are shipped in a separate container.

Section 2, Installation and Operation, gives instructions on inspecting your new Generator. Reshipment information is also included.

1-3. SAFETY

This instruction manual contains information, warnings, and cautions that should be followed to ensure safe operation and to maintain the Generator in a safe condition.

The Generator is designed primarily for indoor use, and it may be operated in temperatures from 0°C to 50°C without degradation of its safety.

WARNING

TO AVOID ELECTRIC SHOCK, USE A POWER CORD THAT HAS A THREE-PRONG PLUG. IF YOU DO NOT USE A PROPER POWER CORD, THE 6060A/AN CASE CAN DEVELOP AN ELECTRICAL POTENTIAL ABOVE EARTH GROUND.

CAUTION

To avoid damage to the 6060A/AN, check that the rear panel line voltage selection card and fuse are correct for the line voltage in your area. The correct line voltage and fuse combinations are:

LINE VOLTAGE	FUSE
115V ac, $\pm 10\%$, 47 Hz to 400 Hz	1.5 AMP
230V ac, $\pm 10\%$, 47 Hz to 400 Hz	.75 AMP

1-4. GENERATOR DESCRIPTION

Fundamental features of the Generator are as follows:

0.01-MHz to 520-MHz output frequency range in 10-Hz steps

+13-dBm to -127-dBm level range in 0.1-dB steps

AM and FM, internal or external

Internal 400-Hz and 1000-Hz modulation oscillator

FM Deviation Meter

Relative frequency and amplitude

Volts/dBm conversion

Store/recall memory

Master/slave for frequency, amplitude, and modulation step (IEEE-488 Interface controlled)

Fluorescent display, 5 ¼-inches high, rack mountable (with optional kit)

1-5. Controller Functions

The Controller microprocessor controls all operator interface functions, performs background operations such as status checks, and updates (strokes) the front panel displays. Whether you are using local control with the front panel, or remote control with the IEEE-488 Interface, the microprocessor provides self test and diagnostic capability. Economical instrument performance is achieved by using software compensation EPROMs and accuracy-enhancement circuitry.

1-6. LOCAL CONTROL

The value of the basic parameters of the Generator, i.e., amplitude, frequency, or modulation can be controlled in three ways:

Direct numeric entry

Incrementing or decrementing the bright digit

Step-up or step-down entry where the step size can be operator programmed

Other controls provide selection of the POWER ON/OFF, RF OUTPUT ON/OFF, MODULATION ON/OFF, internal/external frequency reference, and STATUS.

1-7. DISPLAY FIELD

The programmed values of modulation, frequency, and amplitude are displayed in the three display fields. When in the deviation meter mode, the measured deviation, frequency, and detector status are displayed in the three display fields.

1-8. REMOTE-CONTROL PROGRAMMING

The IEEE-488 Interface allows the Generator to be remotely controlled with any IEEE-488 bus controller. The instrument can also be used on the IEEE-488 bus without a controller in a listen-only or talk-only mode by selecting the appropriate Generator rear panel IEEE-488 switch settings.

All instrument controls can be remotely controlled except the POWER ON/OFF and the rear panel REF INT/EXT switches. The IEEE-488 Interface provides additional commands not available with local control, such as data transfer and individual control of internal I/O control bits.

The IEEE-488 Interface allows two Generators to track amplitude, frequency, or modulation in a master/slave configuration when using the front panel step-up and step-down entries on one of the instruments. For instance, frequency tracking is convenient for tests involving mixers, and amplitude tracking is useful for two-tone intermodulation testing.

1-9. Frequency

The specified frequency range is 0.01 to 520 MHz. The frequency is synthesized from a 10-MHz reference and provides an output resolution of 10 Hz over the entire frequency range. The relative frequency mode allows the frequency to be programmed in relation to a center frequency or an offset frequency. This is convenient for testing filters and mixers. The output frequency stability and accuracy depends on the reference, whether that reference is internal or external.

1-10. Reference

The internal frequency reference is a 10-MHz ambient crystal oscillator. With the rear panel REF INT/EXT switch set to INT, the Generator output frequency is synthesized from the internal 10-MHz crystal oscillator reference, and the internal oscillator (timebase) TTL signal is available at the 10 MHz IN/OUT connector.

The Generator can be operated from an external 10-MHz timebase by setting the rear panel REF INT/EXT switch to EXT and applying a TTL timebase signal to the 10 MHz IN/OUT connector.

1-11. Amplitude

The Generator has a specified signal level range from +13 to -127 dBm with programming limits of +19 and -147.4 dBm. This corresponds to specified terminated voltages of 1V to 0.1 μ V and limits of 2V to 0.01 μ V, respectively. The maximum usable signal level is approximately +15 dBm. The level entry can be in dBm or volts, or it can be converted from one to the other. In addition, the relative amplitude mode allows you to account for cascaded gain or loss, or to display the level (in dB) relative to 1 μ V or 1 mV.

1-12. Modulation

Both internal and external amplitude modulation and frequency modulation capability is available. The internal modulation oscillator is selectable between 400 Hz and 1000 Hz. AM depths of 0% to 99% are available in 1% steps. FM deviation ranges of 10 kHz, 100 kHz, and 500 kHz are available in steps of 10 Hz, 100 Hz, and 1 kHz, respectively.

1-13. Deviation Meter

The deviation meter measures FM deviation in two ranges of 500 kHz and 50 kHz. Deviation measurements can be made over a frequency range of 30 to 500 MHz and a level range of 15 mV to 5V rms. The frequency, displayed in the frequency field, can be varied while making deviation meter measurements. The measured deviation is displayed in the modulation field and the detector status (\pm peak) is displayed in the amplitude field.

INTRODUCTION AND SPECIFICATIONS

1-14. OPTIONS AND ACCESSORIES

The 6060A/AN has no options.

The following accessories are included with each Generator:

Description	Part Number	Quantity
Instruction Manual	755421	2
Line Power Cord	284174	1

The following accessories are available for the Generator:

Description	Accessory No.
Rack Mount Kit. Includes M05-205-600 (5 ¼-inch Rack Mount Ears) and M00-280-610 (24-inch Rack Slides)	Y6001
IEEE-488 Shielded Cable, 1 meter	Y8021
IEEE-488 Shielded Cable, 2 meters	Y8022
IEEE-488 Shielded Cable, 4 meters	Y8023
Coaxial Cable, 50 ohms, 3 feet, BNC (m) both ends	Y9111
Coaxial Cable, 50 ohms, 6 feet, BNC (m) both ends	Y9112

1-15. RECOMMENDED TEST EQUIPMENT

The test equipment recommended for the performance tests, calibration adjustments, and troubleshooting are listed in Table 4A-1. This equipment is assumed to be calibrated to the manufacturer's specifications. If the recommended test equipment is not available, equivalent test equipment can be substituted.

1-16. MNEMONICS

The mnemonics used on the schematics, block diagrams, wiring diagrams, truth tables, and in the text, are listed in Figure 8-1.

1-17. SIGNAL GENERATOR SPECIFICATIONS

Unless otherwise noted, the following performance is guaranteed over the specified environmental and ac power line conditions 1 hour after turn-on. Table 1-1 lists the Generator specifications.

Table 1-1. Signal Generator Specifications

Specifications apply 1 hour after turn-on within operating temperature range.

FREQUENCY (8-1/2 digit display)

- RANGE 0.01 MHz to 520.0 MHz in two bands:
0.01 MHz to 244.99999 MHz
245 MHz to 520.00000 MHz
- RESOLUTION 10 Hz.
- ACCURACY Same as reference (see REFERENCE).
- REFERENCE (Internal) Accuracy within 10 ppm of indicated frequency. Unit operates on an internal free-air 10-MHz crystal oscillator, aging $\lt; \pm 0.5 \text{ ppm/month}$. $\lt; \pm 5 \text{ ppm}$ for 25°C, $\pm 25^\circ\text{C}$. Frequency stability $\lt; \pm 0.5 \text{ ppm/hour}$ 1 hour after warm up. Internal reference signal (10 MHz TTL) available at rear connector.
- (External) Accepts 10-MHz TTL signal.

AMPLITUDE (3-1/2 digit display)

- RANGE (Indicated) +13 (+13 peak on AM) to -127 dBm;
(Autoranging 6-dB step attenuator).
- RESOLUTION 0.1 dB ($\lt; 1\%$ or 1 nV in volts).
- ACCURACY ± 2.5 dB.
- SOURCE SWR $\lt; 1.3$ below -10 dBm.

SPECTRAL PURITY (CW mode only)

- SPURIOUS $\lt; -35 \text{ dBc}$

NOTE

dBc refers to decibels relative to the carrier frequency, or in this case, relative to the signal level.

- HARMONICS $\lt; -30 \text{ dBc}$ from 10 MHz to 520 MHz.
$\lt; -26 \text{ dBc}$ from 0.01 MHz to 10 MHz.
- RESIDUAL FM (peak in 0.05 kHz to 15 kHz band) $\lt; 200 \text{ Hz}$.
- RESIDUAL AM (in 0.05 kHz to 15 kHz band) $\lt; -60 \text{ dBc}$.

AMPLITUDE MODULATION (two-digit display)

- DEPTH RANGE 0% to 99%
- RESOLUTION 1%
- ACCURACY $\pm 6\%$ of setting for internal rates; RF peak amplitude of +13 dBm or less.

INTRODUCTION AND SPECIFICATIONS

Table 1-1. Signal Generator Specifications (cont)

DISTORTION	< 5% THD at 50% AM for 1-kHz rate.
RATES	10 Hz to 20 kHz.
EXTERNAL INPUT LEVEL.....	Less than 10V peak-to-peak into 600 ohms.
FREQUENCY MODULATION (three-digit display)	
DEVIATION RANGES	1 kHz to 9.99 kHz, 10 kHz to 99.9 kHz, and 100 kHz to 500 kHz.
MAXIMUM DEVIATION	500 kHz at rates above 50 Hz. 50 kHz between frequencies of 0.1 MHz and 5 MHz and rates above 50 Hz.
RESOLUTION	Three digits.
ACCURACY	±5% for 1-kHz rate and > 1-kHz deviation.
RATES.....	0.05 kHz to 100 kHz.
EXTERNAL INPUT LEVEL.....	Less than 10V peak-to peak into 600 ohms.
MODULATION SOURCE	
INTERNAL	0.4 kHz or 1 kHz, ±5%
EXTERNAL	±5V max.; 1V peak provides indicated modulation index. Nominal input impedance is 600 ohms.
MODES	Any combination of Internal AM, Internal FM, External AM, and External FM. Modulation may also be disabled. The nominal input impedance with both External AM and External FM enabled is 560 ohms.
DEVIATION METER	
FREQUENCY INPUT	30 MHz to 500 MHz.
INPUT SIGNAL LEVEL	15 mV to 5V rms.
INPUT IMPEDANCE	50 ohms nominal.
MEASUREMENT RANGES	Two ranges of 500 kHz and 50.0 kHz full scale.
POLARITY	Selectable +/- peak.
MODULATION RATE	100 Hz to 8 kHz.
ACCURACY	±6% of full-scale range from 100 Hz to 8 kHz.
GENERAL	
TEMPERATURE Operating	0°C to 50°C (32°F to 122°F)
Non-operating ...	-40°C to 70°C (-40°C to 158°F)
HUMIDITY RANGE	
Operating	0-95% non-condensing.

Table 1-1. Signal Generator Specifications (cont)

VIBRATION			
Non-operating	5 Hz to 15 Hz at 0.06 in, 15 Hz to 25 Hz at 0.04 in, and 25 Hz to 55 Hz at 0.02 in. DA.		
SHOCK			
Non-operating	Bench handling per MIL T 28800C Class 5, Style E.		
ELECTROMAGNETIC COMPATIBILITY			
.....	The radiated emissions induce < 1 uV of the Generator's output signal into a 1-inch diameter, two-turn loop, 1 inch from any surface as measured into a 50-ohm receiver.		
Also complies with the following standards:			
	CE03 of MIL-STD-461B (Power and interconnecting leads), 0.015 MHz to 50 MHz		
	RE02 of MIL-STD-461B (14 kHz to 10 GHz)		
	FCC Part 15 (j), class A		
	CISPR 11		
REVERSE POWER PROTECTION LEVEL			
.....	Up to 50 watts from a 50-ohm source, 0.01 MHz to 520 MHz. Will withstand up to 25V dc. Protection not provided when instrument is off.		
IEEE-488 INTERFACE FUNCTIONS (IEEE Std 488-1978)			
.....	SH1, AH1, T5, TE0, L3, LE0, SR1, RL1, PPO, DC1, DT1, CO, and E1.		
SIZE			
.....	Width	Height	Depth
	43 cm	13.3 cm	55.3 cm
	17 in	5.25 in	21.8 in
POWER			
.....	115V, 230V ac $\pm 10\%$, 47 Hz to 400 Hz, < 100 watts.		
WEIGHT			
.....	< 18.2 kg (40 lbs).		
CALIBRATION INTERVAL			
.....	After calibration, the equipment shall meet each performance requirement within the tolerance specified for a period of 9 months.		
SUPPLEMENTAL CHARACTERISTICS			
The following characteristics are provided to assist in the application of the instrument and to describe the typical performance that can be expected.			
FREQUENCY SWITCHING SPEED ... < 150 ms to be within 100 Hz of final frequency.			
AMPLITUDE SWITCHING SPEED ... < 100 ms to be within 0.1 dB of final amplitude.			
AMPLITUDE RANGE Programmable to +19 dBm and -147.4 dBm, usable to +15 dBm. Fixed-Range, selected by Special Function, allows for more than 12 dB of vernier without switching the attenuator.			

INTRODUCTION AND SPECIFICATIONS

Table 1-1. Signal Generator Specifications (cont)

AM ACCURACY	$\pm(2\% + 4\%$ of setting) for internal rates, for depths 90% or less and peak amplitude of +13 dBm or less.
AM DISTORTION	< 1.5% THD to 30% AM, < 3% to 70% AM, < 5% to 90% AM at internal rates.
INCIDENTAL FM	< $0.3f_m$ for internal rates and 30% AM.
FM ACCURACY	$\pm 7\%$ for rates from 0.3 to 20 kHz > 1 kHz deviation $f_o > 0.4$ MHz.
FM DISTORTION	< 1% THD for rates of 0.3 kHz to 20 kHz, 1 kHz to 99.9 kHz deviation for $f_o > 5$ MHz.
INCIDENTAL AM	< 1% AM at 1 kHz rate, for the maximum deviation or 50 kHz, whichever is less.
RESIDUAL FM (rms in 0.3-kHz to 3-kHz Band).....	< 15 Hz from 245 to 520 MHz; < 30 Hz elsewhere.
RESIDUAL FM (rms in 0.05-kHz to 15-kHz Band).....	< 30 Hz from 245 to 520 MHz; < 60 Hz elsewhere.
NOISE (at 20 kHz offset)	< -113 dBc/Hz (except < -107 dBc/Hz below 245 MHz).
SPURIOUS	< -60 dBc for offsets greater than 10 kHz. Fixed frequency spurs are < -60 dBc or < -140 dBm, whichever is larger.
EXTERNAL MODULATION	Annunciators indicate when a 1V peak signal is applied, $\pm 2\%$, over a 0.02-kHz to 100-kHz band.
DEVIATION METER ACCURACY	$\pm 5\%$ of reading ± 1 count for rates between 100 Hz and 10 kHz.
IEEE-488 INTERFACE	All controls except the power switch and the internal/external reference switch are remotely programmable via IEEE Std 488-1978. All status including option compliment are available remotely. The Store/Recall memory data may be transferred via an external controller. In talk only, the appropriate commands are generated when the front panel step-up and step-down entries are made to control another 6060A/AN, 6060A, 6070A, or 6071A. (The 6070 and 6071A only have FREQUENCY STEP.)

Section 2

Installation and Operation

2-1. INTRODUCTION

This section describes how to install and operate the Generator. This section contains information for initial inspection, setting up the instrument, and local and remote operation.

2-2. INITIAL INSPECTION

The Generator is shipped in a special protective container that should prevent damage during shipment.

If reshipment of the Generator is necessary, please use the original shipping container. If the original container is not available, use a container that provides adequate protection during shipment. It is recommended that the Generator be surrounded by at least 3 inches of shock-absorbing material on all sides of the container. Do not use loose fill to pad the shipping container. Loose fill allows the Generator to settle to one corner of the shipping container, which could result in the Generator being damaged during shipment.

2-3. SETTING UP THE GENERATOR

The following paragraphs describe how to set up the Generator for operation. This information includes: line power requirements, line voltage selection procedures, fuse replacement procedures, and rack mounting instructions.

2-4. Line Power Requirements

The Generator uses a line voltage of 115V ac rms ($\pm 10\%$) with a 1.5A fuse, or 230V ac ($\pm 10\%$) with a 0.75A fuse. The line frequency must be between 50 and 400 Hz, inclusive. The power consumption of the instrument is <100 Watts.

2-5. Line Voltage and Fuse Selection

CAUTION

Verify that the intended line power source matches the line voltage setting of your Generator before plugging in the line power cord.

Refer to Figure 2-1 to set the line voltage of the Generator to match your available source. Figure 2-1 also shows how to replace the line fuse of the Generator. The correct fuse value for each of the two line voltages is listed on a plate attached to the rear panel of the Generator.

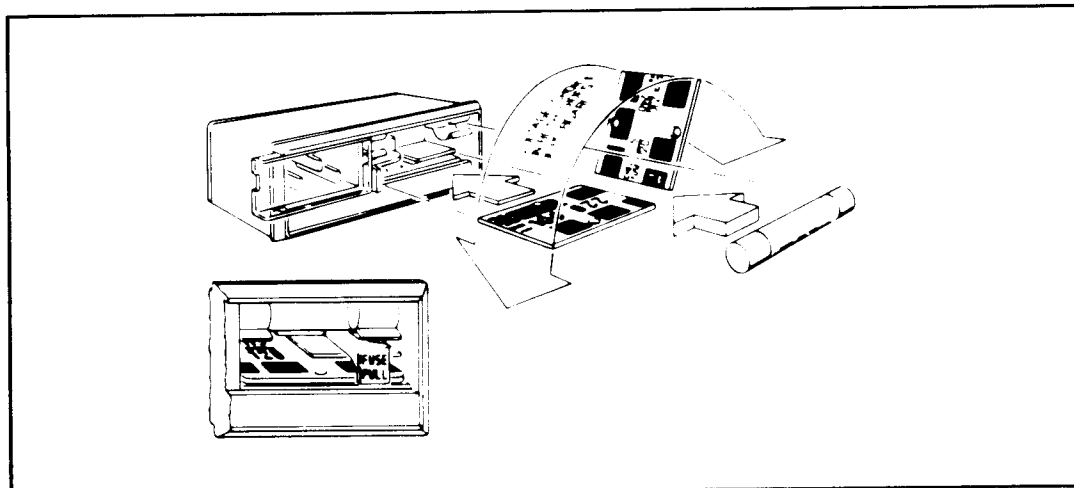

Figure 2-1. Fuse/Filter/Line Voltage Selection Assembly

2-6. IEEE-488 Address

The IEEE-488 address can be selected using the switches located next to the IEEE-488 connector on the rear panel. Talk-only and listen-only modes can also be selected on this switch.

2-7. RACK OR BENCH MOUNTING THE GENERATOR

CAUTION

Allow at least 3 inches of clearance behind and on each side of the Generator to ensure proper air circulation.

To meet the specified radiated emissions, the IEEE-488 connector must be terminated with a shielded IEEE-488 cable, such as a Fluke Y8021.

The Generator normally operates on an internal reference oscillator. However, if desired, the Generator can be operated on an external reference by setting the rear panel REF INT/EXT switch to EXT and connecting the external reference to the 10 MHz IN/OUT connector.

CAUTION

When operating on the internal reference, a 10-MHz TTL signal is present at the 10 MHz IN/OUT connector on the rear panel. To meet the specified radiated emissions, this connector must be terminated with a BNC non-shorting dust cap. A dust cap, JF 478982, is supplied with the Generator. If a cable is connected it must be a double-shielded coaxial cable, such as RG-223 terminated in a TTL load.

CAUTION

Output spectral degradation occurs if the Generator is operated on internal reference with an external reference signal applied.

The Generator may be placed directly on a work bench or mounted in a standard (24-inch deep) equipment rack. Use the Fluke Y6001 Rack Mount Kit for mounting the

Generator on an equipment rack. Instructions for installing the Generator with the Rack Mount Kit are provided in the kit. The outside dimensions of the Generator are shown in Figure 2-2. The Rack Mount Kit is composed of the following parts:

- 5-1/4-inch Rack Adapter, P/N M05-205-600
- 24-inch Rack Slides, P/N M00-280-610

2-8. GENERAL OPERATING INFORMATION

The following paragraphs contain general information on the operation of the Generator. This includes all the information required to familiarize you with the instrument and its different modes of operation.

2-9. Familiarization

Figure 2-3 shows the front panel controls, indicator, and connectors; Table 2-1 describes the features.

Figure 2-4 shows the rear panel controls, connectors, and switches; Table 2-2 describes the features.

2-10. Generator Verses Meter Mode Operation

The 6060A/AN has two modes of operation: the generator mode and the meter mode. In the generator mode of operation the frequency, amplitude, and various modulation parameters may be programmed. The signal generated is available at the RF OUTPUT connector. In the meter mode of operation, the FM deviation of the signal applied to the DEVIATION METER INPUT is measured. The RF frequency of the signal being measured may be programmed. Operation of both modes is described throughout this manual.

2-11. Local Versus Remote Operation

There are two modes of controlling the output of the Generator. One mode uses the keys on the front panel; this is called local operation. The other mode is available when an IEEE-488 controller is used to control the Generator; this is referred to as remote operation. An overview of local control is presented first. The next heading, Operating Reference Material, is divided into two parts. The first part covers local and remote control operations that have similar entry methods. The second part, Remote Operation, contains descriptions or information on commands that pertain only to remote operations.

2-12. Power-On Sequence

When the Generator is turned on, a power-on sequence is started. During the power-on sequence, the microprocessor tests the analog circuitry, the program ROM, the scratch-pad RAM, and the front panel displays. The front panel displays are tested by lighting all segments for a brief period while the rest of the self tests are performed.

If any of the self tests fail, an error code is displayed. If the operator initiates any front panel entry before the power-on sequence is completed, the self test is aborted, and the Generator is placed in the Instrument Preset State [RCL] [9][8]. At power-on, the instrument begins generator mode operation; i.e., the deviation meter mode is off. The power-on values of the deviation meter are as follows:

Meter Mode off ([SPCL] [6][0])
 Deviation Range 500 kHz
 Deviation Peak + PEAK

In addition, the RF output is turned on at power-on. Table 2-3 lists the Instrument Preset State. Power-on instrument settings that relate to the IEEE-488 Interface are described in the REMOTE OPERATION paragraphs in this section.

INSTALLATION AND OPERATION

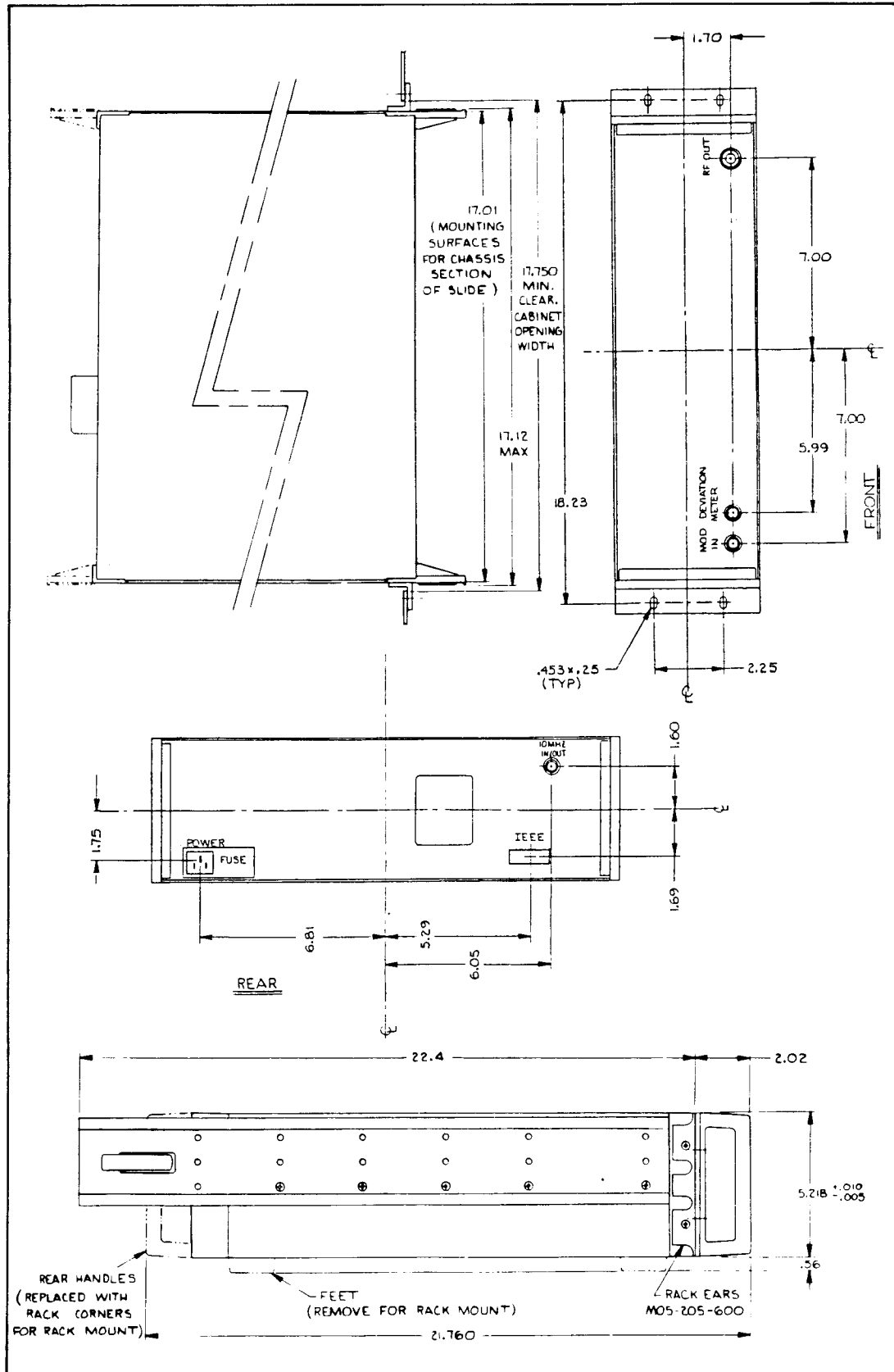

Figure 2-2. 6060A/AN Outside Dimensions

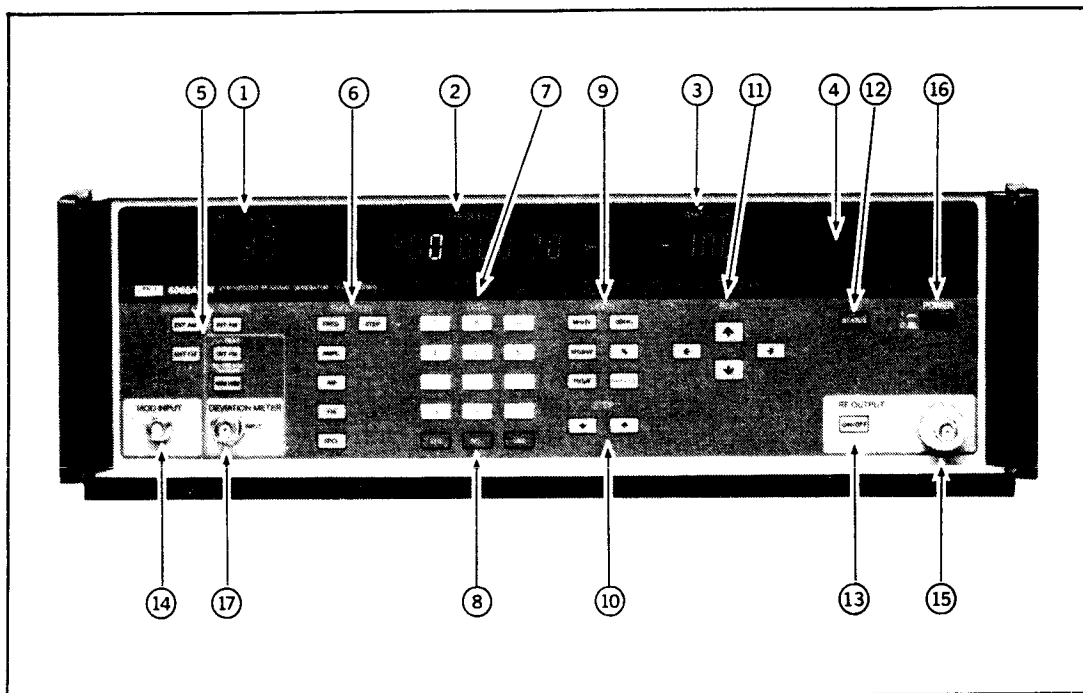

Figure 2-3. Front Panel Controls, Indicators, and Connectors

Table 2-1. Front Panel Controls, Indicators, and Connectors

<p>① MODULATION DISPLAY FIELD</p>	<p>A three-digit display, with associated indicators used to display the AM depth, FM deviation, source of modulation signal, and modulation frequency. In the meter mode, the measured FM deviation is displayed in this field.</p>
<p>INT AM</p>	<p>Indicates that the internal modulation oscillator signal is amplitude modulating the Generator.</p>
<p>EXT AM</p>	<p>Indicates that the Generator is amplitude modulated by the signal connected to the MOD INPUT connector.</p>
<p>INT FM</p>	<p>Indicates that the internal modulation oscillator signal is frequency modulating the Generator.</p>
<p>EXT FM</p>	<p>Indicates that the Generator is frequency modulated by the signal connected to the MOD INPUT connector.</p>
<p>STEP</p>	<p>Indicates that the STEP [^] or [v] keys (Step Entry) affect the current Modulation display value.</p>
<p>%</p>	<p>Indicates that the value displayed is the AM Depth in percent.</p>
<p>kHz DEV</p>	<p>Indicates that the value displayed is the FM Deviation in kHz. In the deviation meter mode, the value displayed is the FM deviation in kHz of the signal connected to the DEVIATION METER INPUT connector.</p>
<p>400 Hz</p>	<p>Indicates that the internal modulating frequency is 400 Hz.</p>
<p>1000 Hz</p>	<p>Indicates that the internal modulating frequency is 1000 Hz.</p>
<p>EXT HI</p>	<p>Indicates that the external modulation signal is more than 2% above the nominal 1V peak requirement for calibrated operation.</p>
<p>EXT LO</p>	<p>Indicates that the external modulation signal is more than 2% below the nominal 1V peak input requirement.</p>

Table 2-1. Front Panel Controls, Indicators, and Connectors (cont)

② FREQUENCY DISPLAY FIELD	An 8 1/2-digit display, with two indicators used to display the output frequency of the Generator and the input frequency of the deviation meter. Also used to display the special function code, status error codes, or the memory location being stored or recalled, as well as relative and actual frequency, when 'REL' is lit, and step frequency.
STEP	Indicates that the STEP [↑] or [↓] keys (Step Entry) affect the output frequency.
REL	Indicates that the displayed frequency is relative to a reference frequency.
③ AMPLITUDE DISPLAY FIELD	A 3 1/2 digit display, with sign and six indicators, used to display the output amplitude of the Generator into a 50-ohm load. In the deviation meter mode, the peak being measured is displayed in this field. "P" indicates the positive peak and "-P" indicates the negative peak.
STEP	Indicates that the STEP [↑] or [↓] keys (Step Entry) affect the output amplitude.
REL	Indicates that the displayed amplitude is relative to a reference amplitude.
dBm	Indicates that the output amplitude is in decibels relative to 1 milliwatt.
V	Indicates that the output amplitude is in volts.
uV	Indicates that the output amplitude is in microvolts.
mV	Indicates that the output amplitude is in millivolts.
④ STATUS DISPLAY FIELD	The status display field is composed of seven indicators used to denote the current status of the Generator or instrument entry.
EXT REF	Indicates that the rear panel REF switch is in the EXT (external) position.
REJ ENTRY	Flashes when an invalid entry is made.
UNCAL	Lights when a parameter entry is outside its specified range. This indicator flashes when any of the internal DAC's are over or under-flow or when any abnormal operation is detected.
RF OFF	Lights when the RF OUTPUT is disabled. This indicator flashes when the Reverse Power Protector (RPP) circuit has tripped.
REMOTE	Lights when the Generator is in the remote (IEEE-488 Interface) mode of operation.
ADDR	Lights when the Generator is addressed to listen or talk.
SRQ	Lights when the Generator has asserted the IEEE-488 SRQ signal.

Table 2-1. Front Panel Controls, Indicators, and Connectors (cont)

<p>⑤ MODULATION ON/OFF</p>	<p>Used to select type, source, and frequency of modulation. With the exception of the [400/1000] key, these keys operate as independent push-on/push-off switches for the given function. Any combination is allowed.</p>
<p>INT AM</p>	<p>Enables internal amplitude modulation at the frequency annunciated by the '400/1000' Hz indicator.</p>
<p>INT FM</p>	<p>Enables internal frequency modulation at the frequency annunciated by the '400/1000' Hz indicator. In the meter mode, toggles the deviation peak between + and -.</p>
<p>EXT AM</p>	<p>Enables external amplitude modulation using the signal applied to the MOD INPUT connector.</p>
<p>EXT FM</p>	<p>Enables external frequency modulation using the signal applied to the MOD INPUT connector.</p>
<p>400/1000</p>	<p>Alternately sets the internal modulation oscillator's frequency to 400 or 1000 Hz. The selected frequency is displayed only when INT AM or INT FM is enabled. In the meter mode, toggles the deviation meter range between 50 kHz and 500 kHz.</p>
<p>⑥ FUNCTION</p>	<p>With the exception of the [STEP] and [SPCL] keys, these keys operate as interlocked switches that select the parameter to be entered or edited. For the [FREQ], [AMPL], [AM], and [FM] FUNCTION keys, the bright digit appears in the corresponding display of the selected function.</p>
<p>FREQ</p>	<p>Selects the frequency parameter of the Generator to be programmed by using the DATA, EDIT, or STEP entry keys.</p>
<p>AMPL</p>	<p>Selects the amplitude parameter of the Generator to be programmed by using the DATA, EDIT, or STEP entry keys.</p>
<p>AM</p>	<p>Selects the amplitude modulation (AM) parameter of the Generator to be programmed by using the DATA, EDIT, or STEP entry keys.</p>
<p>FM</p>	<p>Selects the frequency modulation (FM) parameter of the Generator to be programmed by using the DATA, EDIT, or STEP entry keys.</p>
<p>SPCL</p>	<p>Enables the special function mode. Special functions are called up by a two-digit code, which is entered by using the DATA keys. Refer to the paragraphs on Special Function in this section for a detailed description and a list of the special functions.</p>
<p>STEP</p>	<p>After one of the four parameter functions has been selected for programming, pressing this key allows you to program a step-wise change to that parameter. The step increase or decrease is then performed every time the STEP [↑] or [↓] key is pressed.</p>
<p>⑦ DATA</p>	<p>A 10-digit (plus sign and decimal key) keypad used for entering a parameter's value, the special function code, or a memory recall/store location.</p>

Table 2-1. Front Panel Controls, Indicators, and Connectors (cont)

8 Memory	
STO	Used with the DATA keys to store the current instrument state in a memory location. Memory locations 01 through 03 are available.
RCL	Used with the DATA keys to recall an instrument state from a memory location. Memory locations 01 through 03 are available for operator-stored states; memory location 98 contains the Instrument Preset State (see Table 2-3).
SEQ	Sequentially recalls, in increasing location order, the instrument states stored in memory. While the [SEQ] key is pressed, successive memory locations are displayed and recalled.
9 UNITS	
	These keys, with the exception of [CLR LCL], serve as the terminating keystroke of a function entry, thereby causing the Generator to be programmed. The amplitude units keys are also used during Amplitude Units Conversion entries.
MHz V	Used with the [FREQ], [FM], and [AMPL] function keys to program the numerical DATA entries in terms of megahertz (frequency or frequency modulation) or volts (amplitude).
dB(m)	Used with the [AMPL] function key to program the numerical DATA entries in terms of decibels per milliwatt.
kHz mV	Used with the [FREQ], [FM], and [AMPL] function keys to program the numerical DATA in terms of kilohertz (frequency or frequency modulation) or millivolts (amplitude).
%	Used with the [AM] function key to program the numerical DATA entries in terms of percentage AM depth.
Hz μ V	Used with the [FREQ], [FM], and [AMPL] function keys to program the numerical DATA in terms of hertz (frequency or frequency modulation) or microvolts (amplitude).
CLR LCL	When the Generator is in local operation, this key is used to clear the current entry and returns the Generator to the previous state. When the instrument is in remote operation, this key is used to return local control.
10 STEP	
	These two keys work in conjunction with the STEP Function key. These keys repeat while they remain pressed.
↕	After a parameter is set to the step function mode, and the 'STEP' indicator appears in the display field, this key increments the parameter by the step value previously programmed.
↕	After a parameter is set to the step function mode, and the 'STEP' indicator appears in the display field, this key decrements the parameter by the step value previously programmed.

Table 2-1. Front Panel Controls, Indicators, and Connectors (cont)

⑪ EDIT	These keys are used to position the bright digit within a display field and to increase or decrease the bright digit value. All four keys repeat while they remain pressed. The function keys are used to move the bright digit to the desired display field.
[↕]	Increases the bright-digit value.
[←]	Moves the bright digit one digit to the left.
[↔]	Decreases the bright-digit value.
[→]	Moves the bright digit one digit to the right.
⑫ STATUS	A push-and-hold key that displays the Uncal and Reject Entry status codes in the MODULATION, FREQUENCY, and AMPLITUDE display fields.
⑬ ON/OFF	A push-on/push-off key (with a corresponding 'RF OFF' indicator in the STATUS display field) that enables or disables the output of the Generator.
⑭ Connector	A BNC connector for input of a 1V-peak, external modulation signal.
⑮ Connector	A standard RF connector at the output of the Generator.
⑯ POWER	A push-on/push-off detent switch that applies line power to the Generator.
⑰ Connector	A BNC connector for input of 5V rms MAX signal to be measured by the FM deviation meter.

2-13. Changing Output Parameters

The four parameters of the Generator (i.e., frequency, amplitude, amplitude modulation (AM), and frequency modulation (FM)) may be changed by one of three methods:

- Function Entry (FUNCTION-DATA-UNIT)
- Bright-Digit Edit
- Step Entry

These different methods all accomplish the same result but use different approaches. The reason for this apparent redundancy is to reduce the chance of error during complex test procedures that require continuously resetting parameters or in those cases when a test is partly under remote control and only some of the parameters require changes.

2-14. Function Entry

Changing an instrument parameter with the FUNCTION-DATA-UNIT entry method consists of:

- Selecting the Function to be changed
- Entering the new numerical value of the parameter
- Selecting the Units of the numerical value (megahertz, millivolts, etc.)

The command syntax for function entries is:

Select Function — Enter Data — Select Unit

1. Select one of the four parameters using the FUNCTION keys. The bright digit appears in the corresponding display field. The presence of the bright digit in the display field indicates that the value of the selected parameter is ready to be programmed or changed.
2. Enter the data with the DATA keys. The numerics appear in the appropriate display field.
3. Select a UNIT key. This gives the data its absolute value, and causes the microprocessor to internally program the Generator to the new state.

For the amplitude and frequency functions, the entered data programs the displayed value. If the relative mode is enabled, the displayed value may be different from the actual output value.

Once a function is selected, that parameter or feature remains in the active programming mode until a new function is selected. Data for a selected parameter must be followed by a unit value and must be within the range specified for the function. The display field flashes and the 'REJ ENTRY' status indicator flashes if the entered data is not within the specified range. A rejected entry does not affect the output of the Signal Generator. The output of the Generator remains at its previous values until a new value is accepted.

A function entry may be terminated at any time by the [CLR LCL] key or by selecting another function.

2-15. Bright-Digit Edit Operation

Changing an instrument parameter by the edit entry method is the fastest way to make vernier (incremental) changes to one of the four parameters. The EDIT keys are used with the four parameter FUNCTION keys to position the bright digit in the desired display field and then increase or decrease the bright-digit value.

The command syntax for bright-digit edit entries is:

Select Display Field — Position Bright Digit — Change Bright-Digit Value

1. Use one of the four FUNCTION keys to position the bright digit in the appropriate display field.
2. Use the [←] or [→] EDIT keys to position the bright digit to the desired resolution, and use the [↑] or [↓] EDIT keys to increase or decrease the value of the bright digit.

The position of the bright digit within a display field is maintained when the bright digit is moved from one display field to another.

The repeat rate of the [↑] or [↓] EDIT keys may be changed to a faster or slower rate (a medium repeat rate is the default) with a special function code. Refer to the paragraphs on Special Function and the reference pages in this section for the method and code.

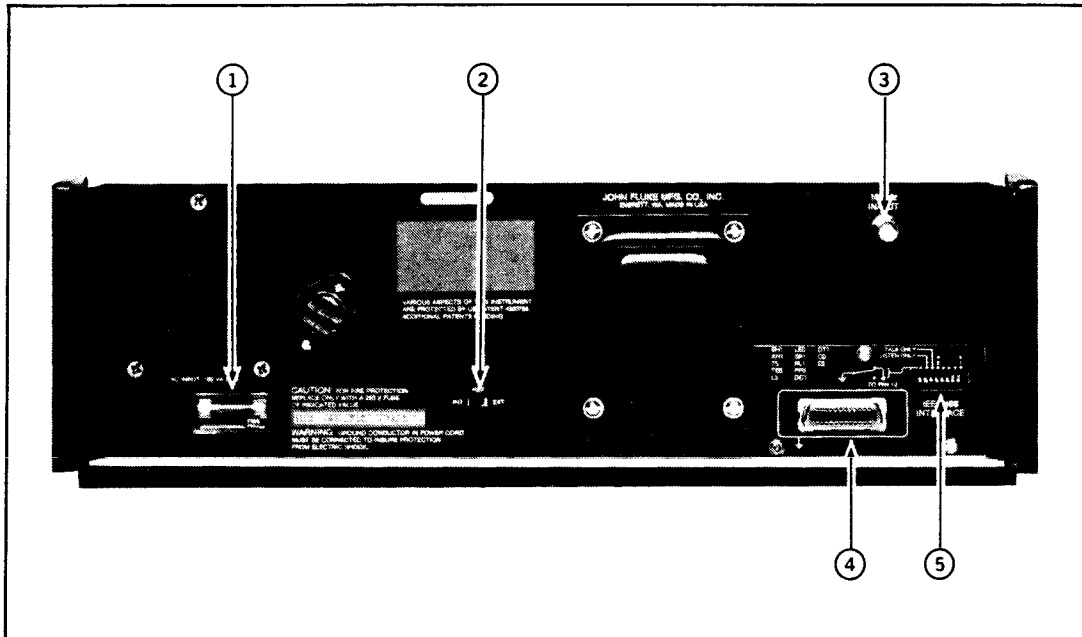

Figure 2-4. Rear Panel Control, Connectors, and Switches

Table 2-2. Rear Panel Controls, Connectors, and Switches

1. AC INPUT	Permits operation from 115 or 230V ac. The number visible through the window on the selector card indicates the nominal line voltage to which the Generator must be connected. The line voltage is selected by orienting the selector card appropriately. A 1 1/2-ampere fuse is required for 115V operation, and a 3/4-ampere fuse is required for 230V operation.
2. REF INT/EXT	Permits selection of the Generator frequency reference. When set to INT, the Generator operates on the internal reference. The internal 10-MHz reference signal is available at the 10 MHZ IN/OUT connector as a TTL level. When set to EXT, the Generator reference is the 10-MHz TTL signal applied to the external 10 MHZ IN/OUT connector.
3. 10 MHZ IN/OUT	10 MHZ IN/OUT connector (BNC) provides a 10-MHz TTL signal when the Generator is operating on the internal reference, or accepts a 10-MHz TTL signal when operating on external reference.
4. IEEE CONNECTOR	Allows remote operation of the Generator via the IEEE-488 bus.
5. IEEE ADDRESS SWITCH	Selects the Generator bus address.

Table 2-3. Instrument Preset State

FUNCTION	SETTING
Frequency	300.00000 MHz
Frequency Step	1.00000 MHz
Amplitude	-10.0 dBm
Amplitude Step	1 dB
Modulation Rate	1000 Hz
AM Depth	30%
AM Depth Step	1%
FM Deviation	50 kHz
FM Deviation Step	1 kHz
Modulation Display	AM Depth
Bright-Digit Location	Frequency Bright Digit
Frequency Bright-Digit Position	1 MHz
Amplitude Bright-Digit Position	1 dBm
AM Bright-Digit Position	1%
FM Bright-Digit Position	100 Hz
Special Functions	20,30,70,80,90
INT AM	Off
EXT AM	Off
INT FM	Off
EXT FM	Off
Step Function	Frequency Step

2-16. Step Operation

Changing parameters by the Step Entry method allows you to preset step-wise increments of a parameter then change that parameter (by the amount programmed in the step function) up or down with a single keystroke using the [↑] or [↓] keys.

The command syntax for step entries is:

Select Step Function — Enter Data — Select Units — Change Parameter

1. Select the parameter to be changed step-wise using one of the FUNCTION keys.
2. Press the [STEP] key to enable the Step function.
3. Program the step amount using the DATA and UNIT keys.
4. The parameter value can now be increased or decreased by the programmed step amount by using the [↑] or [↓] STEP keys.

While the [STEP] key is pressed, the display field of the selected parameter shows the step amount. The 'STEP' indicator is lit in the display field currently affected by the [STEP] key.

The repeat rate of the [↑] and [↓] STEP keys may be changed to a faster or slower rate (a medium repeat rate is the default) with a Special Function code. Refer to the paragraphs on Special Function and the reference material for the method and code.

A step entry is ignored when the result of that step entry would cause the value of the parameter to exceed its programmable limit.

2-17. Status and Clear Entries

The Status entry allows you to interrogate the Generator for an explanation if the uncalibrated or rejected entry operation ('UNCAL' or 'REJ ENTRY') indicator is lit. Refer to the paragraphs on Status and Clear Entry in the reference section for a complete list of status codes.

The [CLR LCL] key may be used to clear a partial DATA entry or clear the flashing 'REJ ENTRY' indicator.

2-18. RF Output On/Off

The RF OUTPUT [ON/OFF] key allows the operator to enable or disable the RF output of the Generator. This feature is useful in zeroing a power meter, finding the noise floor of a system, or determining the presence or source of an unknown signal.

On power-up, the RF output of the Generator is enabled. Pressing the RF OUTPUT [ON/OFF] key disables the output of the Generator and causes the 'RF OFF' indicator (in the STATUS display field) to light.

2-19. Modulation On/Off and Rate

The MODULATION ON/OFF keys allow you to select any combination of modulation or no modulation. The MODULATION display field indicates what combination of modulation has been selected. Each modulation key is a push-on push-off type (except the [400/1000] key).

The [400/1000] key toggles the internal modulation oscillator between 400 and 1000 Hz. The '400 Hz' and '1000 Hz' indicators are lit only when INT AM or FM modulation is enabled.

2-20. Deviation Meter

In the meter mode, the deviation meter measures FM deviation for RF frequencies between 30 and 500 MHz. There are two deviation ranges of 500 and 50 kHz full scale. Either the positive or negative peak deviation may be measured. The meter mode is enabled with the [SPCL] [6][1] key sequence.

2-21. Memory

Memory entry using the [STO] key allows you to save up to three complete front panel settings for later recall.

The command syntax for memory operations follows. No memory location needs to be specified for the sequence operation.

Select Memory Function — Enter Memory Location

To store the current front panel setting, press the [STO] key (located below the DATA keys). The last memory location stored or recalled is displayed in the FREQUENCY display field. Next, use the DATA keys to enter the two-digit memory location code. The location code must contain both digits (e.g., 01, 02, ...03). The two-digit code appears in the FREQUENCY display field as it is entered.

To recall a front panel setting, press the [RCL] key (located below the DATA keys). The last memory location stored or recalled is displayed in the FREQUENCY display field. Next, use the DATA keys to enter the memory location code of the desired front panel setting. Remember, the location code must contain both digits of the memory location code.

Memory location 98 contains the Instrument Preset State, which can be recalled at any time.

The [SEQ] key allows the front panel settings stored in memory to be sequentially recalled. This process is activated by pressing the [SEQ] key at any time. When the [SEQ] key is pressed, the memory location code of the currently recalled setting appears in the FREQUENCY display field, and the location is recalled. When the last memory location is reached (03), the [SEQ] key starts over at 01. The [SEQ] key repeats while pressed.

2-22. Special Function

Special Function Entries allow the operator to enable several special operating functions in the Generator. For example, special functions allow the operator to change the repeat rate of the STEP and EDIT keys, start the self tests, display the results of the power-up self tests, display the IEEE-488 address, enable relative and fixed-range features, and disable or enable special attenuation features. A complete list of the special functions available is presented in Table 2-4.

Table 2-4. Special Functions

SPECIAL FUNCTION	OPERATION
00	Clears all currently set special functions.
02	Initiates self tests.
03	Display test. This test is described in Section 3.
04	Key test. This test is described in Section 3.
07	Set IEEE-488 SRQ signal.
08	Reset IEEE-488 SRQ signal.
09	Display instrument software revision level. Information appears in the MODULATION and FREQUENCY display fields for approximately 3 seconds or until another key is pressed.
10	Display IEEE-488 mode and address in decimal form.
11	Display self-test results. Zeros in the display fields indicate that the self-tests have passed. See Section 4 for details of the self-test display.
12	Turn on displays.
13	Turn off all displays. All other functions still operate.
14	Initialize memory locations to Instrument Preset State. 'Sto' appears in the FREQUENCY display field for 3 seconds. If during this time, the [STO] key is pressed, all memory locations are initialized.
15	Latch test. This test is described in Section 4.
20	Disable Relative Frequency. See reference page on Relative Function.
21	Enable Relative Frequency. See reference page on Relative Function.
30	Disable Relative Amplitude. See reference page on Relative Function.
31	Enable Relative Amplitude. See reference page on Relative Function.
60	Disable meter mode operation.
61	Enable meter mode operation.
70	Set repeat rate for EDIT and STEP keys to medium.
71	Set repeat rate for EDIT and STEP keys to fast.
72	Set repeat rate for EDIT and STEP keys to slow.
80	Enable Amplitude correction. Normal operation.
81	Disable Amplitude correction. If level accuracy is not critical, level correction circuitry can be disabled for improved programming speed. Level accuracy may be up to 7 dB low.
82	Disable attenuator correction. Useful as a troubleshooting tool. RF input to attenuator is flat.
83	Program alternate 24 dB attenuation. See Section 4.
84	Program alternate 24 dB attenuation. See Section 4.
85	Program alternate 24 dB attenuation. See Section 4.
86	Program alternate 24 dB attenuation. See Section 4.
90	Disable Amplitude Fixed Range. See reference material on Amplitude Fixed Range.
91	Enable Amplitude Fixed Range. See reference material on Amplitude Fixed Range.

The command syntax for special function entries is as follows:

Select Special Function — Enter Special Function Code

The special function is selected by pressing the [SPCL] key. The special function code is entered using the DATA keys.

2-23. OPERATING REFERENCE MATERIAL

This reference section describes local and remote operation for each Generator function. The functions are arranged in alphabetical order. For each function the syntax of the command, allowable data ranges, and other information is presented.

2-24. Amplitude and Frequency Entry

The following information describes how to control the carrier frequency and amplitude by the FUNCTION-DATA-UNIT entry sequence. This method applies to both normal and relative operations. The frequency display is a fixed-point display in MHz. The amplitude display is fixed point while displaying dBm but is floating point when displaying voltage units.

The RF OUTPUT [ON/OFF] must be enabled for the Generator to produce an output (see the reference material on RF OUTPUT ON/OFF Entry).

Command Syntax

Select Function — Enter Data — Select Unit

Summary

	COMMAND	RANGE	RESOLUTION	NOTES
Set Frequency				
Local:	[FREQ] -- DATA -- [MHz V] [kHz mV] [Hz uV]	0.01 to 570 MHz	10 Hz	1,2,6
Remote:	"FR" -- float -- "G7" "MZ" "KZ" "HZ"	0.01 to 570 MHz	10 Hz	1,3,6
Set Amplitude				
Local:	[AMPL] -- DATA -- [dB(m)] [MHz V] [kHz mV] [Hz uV]	-127 to +13 dBm 0.1 uV to 1V	0.1 dBm 3 digits	2,4,5,7
Remote:	"AP" -- float -- "DB" "V" "MV" "UV" "NV"	-127 to +13 dBm 0.1 uV to 1V	0.1 dBm 3 digits	3,4,5,7

Example

Set Frequency to 10.7 MHz and Amplitude to -7.5 dBm.

```
Local: [FREQ] [1] [0] [.] [7] [MHz|V]
       [AMPL] [-] [7] [.] [5] [dB(m)]

Remote: "FR10.7MZ .AP-7.5DB"
```

Notes

1. Frequency ranging occurs at 245 MHz.
2. FUNCTION ([FREQ] or [AMPL]) remains selected until another FUNCTION or [STEP], [STO], [RCL], or [SPCL] is pressed.
3. float equals floating-point number.
4. Amplitude uncalibrated range from -147.4 to -127.1 dBm and from +13.1 to +19 dBm.
5. Amplitude ranging occurs at $\frac{1}{2}V$, $\frac{1}{4}V$, $\frac{1}{8}V$, ... $\frac{1}{2}^{23}V$ with AM off and $\frac{1}{4}V$, $\frac{1}{8}V$, $\frac{1}{16}V$, ... $\frac{1}{2}^{24}V$ with AM on.
6. In the meter mode of operation, the allowed frequency range is 30 to 500 MHz.
7. The amplitude is not programmable when in the meter mode of operation.

Related Operations

Amplitude Fixed Range
 Bright-Digit Edit Entry
 Relative Function
 Step Entry

2-25. Amplitude Fixed Range

The following information describes how to use the Fixed-Range special function. This special function fixes the current amplitude range (holds the currently selected step of the Step Attenuator). This function allows monotonic and nontransient level control over a limited range around those levels where the Step Attenuator normally autoranges. This level control may be accomplished with the Bright-Digit Edit Entry only.

The level vernier in fixed range has at least 12 dB of range.

Command Syntax

Select Fixed Range — Enable or Disable

Summary

	COMMAND	NOTES
Enable Fixed Range		
Local:	[SPCL] [9] -- [1]	1,3
Remote:	"SP" "9" -- "1"	
Disable Fixed Range		
Local:	[SPCL] [9] -- [0]	2,3
Remote:	"SP" "9" -- "0"	

Example

Set the Generator for monotonic and nontransient amplitude control (Bright-Digit Edit only) over the range of the vernier level control below 0.25V.

```
Local: [AMPL] [-] [2] [5] [MHz|V] [SPCL] [9] [1]
Remote: "AP.25V.SP91"
```

Notes

1. The amplitude range is fixed only for Bright-Digit Edit operations. Other methods of changing the amplitude cause the step attenuator to autorange if necessary.
2. With amplitude fixed range disabled, amplitude ranging occurs at 1/2V, 1/4V, 1/8V, ... 1/2²³V with AM off and 1/4V, 1/8V, 1/16V, ... 1/2²⁴V with AM on.
3. Amplitude fixed-range operation is not allowed when in the meter mode of operation.

Related Operations

Bright-Digit Edit Entry
Relative Function

2-26. Amplitude Units Conversion

The following information describes how to convert the displayed amplitude level from dBm to volts and volts to dBm. The output of the Generator does not change during these operations.

Command Syntax

Select Amplitude Function — Select Unit

Summary

	COMMAND	NOTE
Convert dBm to volts		
Local:	[AMPL] -- [MHz V] [kHz mV] [Hz uV]	1,2
Remote:	"AP" -- "V" "mV" "uV" "nV"	1,2
Convert volts to dBm		
Local:	[AMPL] -- [dB(m)]	
Remote:	"AP" -- "dB"	

Example

Change the displayed amplitude of -10.0 dBm to its voltage equivalent.

```
Local: [AMPL] [MHz|V]
Remote: "APV"
```

INSTALLATION AND OPERATION

Note

1. Any voltage unit is accepted since the microprocessor automatically selects the units appropriate for the value being displayed.
2. Amplitude units conversion is not allowed when in the meter mode of operation.

Related Operations

Relative Function

2-27. Bright-Digit Edit Entry

The following information describes how to use a Bright-Digit Edit Entry to change an instrument parameter. The output frequency, amplitude and the modulation indices can be modified with this entry method.

The RF OUTPUT [ON/OFF] must be enabled for the Generator to produce an output. (See the reference material on RF OUTPUT ON/OFF Entry.)

Command Syntax

Select Display Field — Position Bright Digit — Change Bright-Digit Value

Summary

	COMMAND	NOTES
Edit Frequency		
Local:	[FREQ] -- EDIT [←]/[→] -- EDIT [↑]/[↓]	1,2
Remote:	"FB" -- float "G7" -- "KF" float "MZ" "KZ" "HZ"	3,4,5
Edit Amplitude		
Local:	[AMPL] -- EDIT [←]/[→] -- EDIT [↑]/[↓]	1,2,6
Remote:	"AB" -- float "DB" -- "KA" float "V" "MV" "UV" "NV"	3,4,5,6
Edit FM Deviation		
Local:	[FM] -- EDIT [←]/[→] -- EDIT [↑]/[↓]	1,2,6
Remote:	"DB" -- float "G7" -- "KD" float "MZ" "KZ" "HZ"	3,4,5,6
Edit AM Depth		
Local:	[AM] -- EDIT [←]/[→] -- EDIT [↑]/[↓]	1,2,6
Remote:	"PB" -- float "PC" -- "KP" float	3,4,5,6

Example 1

Edit the displayed amplitude of 9.7 dBm to 10.0 dBm.

Local: Put the bright digit in the amplitude display by pressing [AMPL]. Select the least significant digit in that display by pressing EDIT [→] until the bright digit is on that digit. Increase the value of that digit by pressing EDIT [↑] 3 times.

Remote: "AB.1DB.KA3"

Example 2

Edit the displayed FM Deviation from 5.0 kHz to 3.0 kHz.

Local: Put the bright digit in the FM display by pressing [FM]. Select the 1-kHz digit by pressing the EDIT [→] or EDIT [←] until the bright digit is on that digit. Decrease the value of that digit by pressing EDIT [↓] twice.

Remote: "DB1KZ.KD-2"

Notes

1. The bright-digit field remains selected until another display field is selected.
2. The bright-digit position is maintained for each of the four functions so that the bright digit can be moved from one display to another and back without losing its position in that previous display field.
3. float equals floating-point number.
4. In remote, the bright digit is positioned within a display field using a decade value and associated unit. Minus signs are ignored.
5. In remote, the bright digit is moved to the corresponding field and is increased or decreased by the signed integer following the "KF,KA,KD,KP" messages. The generic edit command "KB" may also be used to edit up or down the current bright-digit position. Positive integers do not require a sign.
6. Only frequency bright-digit operations are allowed when in the meter mode of operation.

Related Operations

Relative Function
Amplitude Fixed Range

2-28. Deviation Meter Entry

To enable the deviation meter mode enter [SPCL] [6] [1]. To return to the generator mode enter [SPCL] [6] [0]. While in the meter mode, the operation of the generator is limited to programming, editing, and stepping frequency. The frequency operation while in the meter mode is the same as described in paragraphs titled "Amplitude and Frequency Entry" in this section. In addition, the status entry and the following special functions are allowed: 00, 02, 03, 04, 07, 08, 09, 10, 11, 12, 13, 14, 15, 20, 21, 60, 61, 70, 71, 72. Recall and sequence entries will turn the meter mode off. Other entries such as amplitude and modulation are ignored while in the meter mode.

In the meter mode, the frequency is limited to between 30 MHz and 500 MHz. Therefore, when entering the meter mode, if the RF frequency is greater than 500 MHz, 500 MHz is programmed; and if the RF frequency is less than 30 MHz, 30 MHz is programmed. Changes made to the instrument parameters while in the meter mode will be retained when returning to the generator mode. All other generator parameters will not be changed when returning to the generator mode.

Command Syntax

Select Meter Function — Select Code

Summary

COMMAND	NOTES
Meter mode on/off	
Local: [SPCL] [6] -- [1] or [0]	1,2
Remote: "SP6" -- "1" or "0"	1,2
Meter peak	
Local: [INT FM] (+/- PEAK)	1,3
Remote: "PK" "0" or "1"	1,4
Meter range	
Local: [400/1000] (500/50 kHz RANGES)	1,5
Remote: "DR" "0" or "1"	1,6

Notes

1. The power-on values are: meter mode off, positive peak, and 500 kHz range. These power-on values are also programmed on [SPCL] [0][2] and on IEEE-488 clear commands ("CL", SDC, and DCL).
2. 0 selects meter mode off, 1 selects meter mode on.
3. This entry toggles between the positive and negative peaks. This entry is only allowed when in the meter mode. The selected peak is displayed in the AMPLITUDE display as "P" or "-P".
4. 0 selects the positive peak, 1 selects the negative peak. The selected peak is displayed in the AMPLITUDE display as "P" or "-P".

5. This entry toggles between the 500 kHz and 50 kHz ranges. This entry is only allowed when in the meter mode.
6. 0 selects the 500 kHz range, 1 selects the 50.0 kHz range.

The measured deviation will be displayed with three digits of resolution in the MODULATION display. Several special displays and their meanings are:

Display	Meaning
123	Normal reading in 500 kHz range.
12.3	Normal reading in 50 kHz range.
OL	Reading is over 510 kHz.
OL	Reading is over 51.0 kHz.
---	Reading is invalid in 500 kHz range.
---.	Reading is invalid in 50 kHz range.

The reading may be invalid for three reasons. The 6060A/AN RF frequency must be programmed to within 250 kHz of the UUT output frequency. If it is outside this range, the reading will be invalid. At power on, the reading is set to invalid. The reading may also be invalid if the deviation meter hardware is not functioning properly.

The IEEE-488 command "IF" can be used to interrogate the deviation. The last measured deviation will be sent to the IEEE-488 interface. If the 6060A/AN is currently in the generator mode, the last deviation measured will be sent. Readings are taken approximately every 105 msec when in the meter mode. The response will be as follows:

Character Number	Values	Description
1	"+" or "-"	Positive or negative peak
2,3,4,5	nnn. or nn.n	Reading in 500 kHz or 50 kHz range
6	"E"	Start of exponent
7	"+"	Positive exponent
8,9	"3", "6", "9"	Normal, invalid, overrange reading
10	<EOR>	The end of record character

Example

- "+123.E+3" <EOR> Positive peak, deviation of 123 kHz.
- "-10.0E+9" <EOR> Negative peak, overrange in 50 kHz range.

2-29. Memory Entry

The following information describes how to use the memory function to store and recall front panel settings. The Generator has three memory locations for storing settings that are lost if the power is turned off. The deviation meter status and RF on/off status are not stored in memory locations.

The sequence feature allows the operator to recall successive memory locations.

Command Syntax

Select Memory Function — Enter Memory Location

Summary

	COMMAND	NOTES
Store		
Local:	[ST0] -- [n] [n]	1,2,3,7
Remote:	"ST" -- int	1,4,7
Recall		
Local:	[RCL] -- [n] [n]	1,2,3,8
Remote:	"RC" -- int	1,4,8
Sequence		
Local:	[SEQ]	5,6,8
Remote:	"SQ"	5,8

Example

Recall the Instrument Preset State (located in memory location 98). Change the frequency parameter to 302 MHz, then store the new front panel setting in memory location 02.

```
Local: [RCL] [9][8]  EDIT [↑] [^] [ST0] [0][2]
Remote: "RC98,KF2,ST2"
```

Notes

- The memory locations available for operator use are 01 through 03. Additionally, the following special memory locations are available:
 - Memory location 00 contains a backup-memory location. After a recall (or sequence) operation, it contains the last front panel setting. After a store operation, it contains the data in the stored memory location before the store operation. Thus, a recall operation can be reversed by recalling location 00.
 - Memory location 98 contains the Instrument Preset State.
 - Memory location 99 contains the present instrument state.
- In local control, two data digits must be entered to specify the memory location. The recall or store is performed when the second digit is released.
- The last memory location specified (used for sequence operations) is displayed while the [STO] or [RCL] button is pressed.
- int equals unsigned integer.
- The sequence operation recalls the next higher memory location, starting from the last memory location stored or recalled. No memory location needs to be specified. When the highest location is reached, the sequence starts over again at location 01.

6. While [SEQ] is pressed, the next memory location number is displayed and the memory location is recalled. This key is repeating.
7. The store operation is not allowed when in the meter mode of operation.
8. A recall or sequence operation will turn the meter mode off; i.e., return to generator mode.

2-30. Modulation Entry

The following information describes how to preset the modulation index (AM depth or FM deviation), internal modulation rate (400 or 1000 Hz), and how to select the modulation source (internal and/or external).

The FUNCTION-DATA-UNIT method of selecting the modulation index is summarized in the following command syntax. The indices may also be modified using Bright-Digit Edit or Step Entry. Since there is only one modulation display, the modulation index displayed is determined by the last modulation FUNCTION key pressed.

Command Syntax

Select Function — Enter Data — Select Unit

Summary

	COMMAND	RANGE	RESOLUTION	NOTES
Set AM Depth				
Local:	[AM] -- DATA -- [%]	0 to 99%	1%	1,2,10
Remote:	"AM" -- float -- "PC"	0 to 99%	1%	1,3,10
Set FM Deviation				
Local:	[FM] -- DATA -- [MHz V] [kHz mV] [Hz uV]	1.00 to 9.99 kHz 10.0 to 99.9 kHz 100. to 500. kHz	0.01 kHz 0.10 kHz 1.00 kHz	1,4,10
Remote:	"FM" -- float -- "GZ" "MZ" "KZ" "HZ"	1.00 to 9.99 kHz 10.0 to 99.9 kHz 100. to 500. kHz	0.01 kHz 0.10 kHz 1.00 kHz	1,3,4,10

Summary

	COMMAND	NOTES
Select Modulation Rate		
Local:	[400/1000]	5,10
Remote:	"MR" "0" or "1"	6,10

Summary

	COMMAND	NOTES
Enable or Disable Modulation		
Local:	[INT AM] [INT FM] [EXT AM] [EXT FM]	7,8,10
Remote:	"AI" "0" or "1" "FI" "0" or "1" "AE" "0" or "1" "FE" "0" or "1"	9,10

Example

Set the FM deviation to 5 kHz, the modulation rate to 400 Hz, and internally modulate the carrier.

```
Local: [FM] [5] [kHz] [INT FM] [400/1000]
Remote: "FM5KZ-MR0,F11"
```

Notes

1. This operation does not change the Generator output unless the corresponding modulation is enabled.
2. Uncalibrated if peak amplitude exceeds +13 dBm.
3. float equals floating-point number.
4. Uncalibrated if FM is enabled and FM deviation is below 1 kHz or if the FM deviation is greater than 50 kHz and the RF frequency is less than or equal to 5 MHz.
5. Toggles between 400 or 1000 Hz only. An indicator shows selected rate only if internal modulation is on.
6. "0" selects a modulation rate of 400 Hz; "1" selects 1000 Hz.
7. These are ON/OFF operations; any combination is allowed.
8. Two indicators 'EXT HI' and 'EXT LO' are lit when external modulation is on to indicate that the external modulation signal is 2% above or 2% below the nominal 1V peak input requirement.
9. "0" turns the modulation source off; "1" turns it on.
10. Modulation entries are not allowed when in the meter mode of operation.

Related Operations

Bright-Digit Edit Entry
Step Entry

2-31. Relative Function

The following paragraphs describe how to change frequency and amplitude using the Relative mode. There are two steps:

1. Setting the reference
2. Changing the parameter relative to that reference

The reference is set by setting the parameter to the desired value and then enabling the relative mode for that parameter. This causes the 'REL' indicator to light and the displayed value to be zero in the corresponding display. The Generator output does not

change during these operations. In the relative mode, the usual means of changing the parameter may be used, i.e., FUNCTION-DATA-UNIT, Step, or Bright-Digit Edit Entry.

In the relative frequency mode, the actual frequency is the sum of the reference and the displayed frequency. The actual frequency may be displayed by pressing the [FREQ] key.

In the relative amplitude mode, the actual amplitude is the sum of the reference and the displayed amplitude when the reference and the displayed quantities have the same units. However, with mixed units (volts and dB), the actual amplitude is the voltage value scaled by the dB value. The actual amplitude may be displayed by pressing the [AMPL] key.

Command Syntax

Select Relative Function — Enable or Disable

Summary

	COMMAND	NOTES
Frequency		
Local:	[SPCL] [2] -- [0] or [1]	1
Remote:	"SP" "2" -- "0" or "1"	1
Amplitude		
Local:	[SPCL] [3] -- [0] or [1]	1,2
Remote:	"SP" "3" -- "0" or "1"	1,2

Example

Set the amplitude to -15 dB μ V; i.e., 15 dB below 1 microvolt.

Local: [AMPL] [1] [Hz| μ V] [SPCL] [3] [1] [AMPL] [-] [1] [5] [dB(m)]

Remote: "AP1UV.SP31,AP-15DB"

Notes

1. 1 enables the relative function; 0 disables the relative function.
2. Relative amplitude operation is not allowed when in the meter mode of operation.

Related Operations

Amplitude and Frequency Entry
 Bright-Digit Edit Entry
 Step Entry

2-32. RF OUTPUT ON/OFF Entry

The following information describes how to enable the output of the Generator using the RF OUTPUT [ON/OFF] key and the corresponding remote code.

Command Syntax

RF Output On/Off

Summary

	COMMAND	NOTES
RF Output On		
Local:	RF OUTPUT [ON/OFF] when 'RF OFF' is on	1,2
Remote:	"R01"	1,2
RF Output Off		
Local:	RF OUTPUT [ON/OFF] when 'RF OFF' is off	2
Remote:	"R00"	2

Notes

1. Turning the RF Output on resets the RPP circuitry if it has tripped.
2. RF output on/off entries are not allowed when in the meter mode of operation.

2-33. Special Function Entry

The following information describes how to use the Special Function Entry in order to control the special operating functions of the Signal Generator. Table 2-4 lists the special functions available.

The special function code is a two-digit number. The first digit indicates the classification of the special function, and the second digit specifies the particular special function.

The special function is executed when the second special function code digit is entered. There are ten classes of special functions. The special functions in the 0(n), 1(n), and 6(n) class cause an action to be performed. Classes 2(n) through 5(n) and 7(n) through 9(n) cause an instrument state to change. These instrument states are stored in memory locations. The status of classes 2(n) through 9(n) appears (left to right) in the frequency display field when the [SPCL] key is pressed.

Command Syntax

Select Special Function — Enter Special Function Code

	COMMAND	NOTES
Local:	[SPCL] -- [n] [n]	
Remote:	"SP" -- int	1,2

Example

Change the repeat rate of the EDIT and STEP keys to slow.

Local:	[SPCL] [7] [2]
Remote:	"SP72"

Notes

1. int equals unsigned integer.
2. The following special functions are not allowed when in the meter mode of operation: 30/31, 80-86, 90/91.

Table 2-4 describes the special functions available with the Generator.

Related Operations

Fixed Range
Relative Function

2-34. Status and Clear Entry

The Status entry allows you to interrogate the Generator for an explanation of either uncalibrated operation ('UNCAL' indicator is lit) or rejected entry operation (the 'REJ ENTRY' indicator is lit).

When either the 'UNCAL' or 'REJ ENTRY' indicator is lit, press and hold the [STATUS] key to display the Uncalibrated or Rejected Entry Error Code Message. These messages provide detailed information on the nature of the uncalibrated or rejected entry condition. Table 2-5 contains a list and explanation of all the Uncalibrated Error Code Messages. Table 2-6 contains a list and explanation of all the Rejected Entry Error Code messages.

The [CLR LCL] key may be used to clear a partial DATA entry or clear the flashing 'REJ ENTRY' indicator. Press the [STATUS] key while an 'UNCAL' indication exists to display the Uncal Error Codes in three fields.

Flashing codes (denoted by *) indicate abnormal operation or aberrated output. Non-flashing codes indicate operation outside specified range.

Table 2-5. UNCAL Error Codes

CODE	DESCRIPTION
000 000 000	= Indicates no UNCAL conditions
001 000 000	= FM deviation < 1 kHz
002 000 000	= FM deviation > 50 kHz and freq <= 5 MHz
*004 000 000	= Excess FM deviation, main or reference PLL unlocked
*000 010 000	= Main or reference PLL unlocked
000 000 001	= Level vernier below calibrated range or level < -127 dBm
000 000 002	= Peak (AM) amplitude > +13 dBm
*000 000 004	= Amplitude unleveled
*000 000 010	= Fixed-range level vernier at 0
*000 000 020	= Fixed-range level vernier at full scale
*000 000 040	= RPP tripped
000 000 100	= Level below -127 dBm
000 000 200	= Level correction disabled
*000 000 400	= RF output off

Table 2-6. REject ENTRY Codes

CODE	DESCRIPTION
001 000 000	= FM deviation not between 0 and 500 kHz
002 000 000	= FM deviation Step not between 0 and 500 kHz
004 000 000	= AM depth not between 0 and 99%
010 000 000	= AM depth step not between 0 and 99%
020 000 000	= IEEE-488 command syntax error
040 000 000	= IEEE-488 input value out of range
200 000 000	= IEEE-488 edit or step operation beyond allowed range
400 000 000	= Entry not allowed while in the meter mode
000 001 000	= Frequency not between 0.01 and 520 MHz or 30 and 500 MHz in the meter mode
000 004 000	= Frequency step not between 0 and 520 MHz
000 040 000	= Invalid memory location
000 100 000	= Invalid data in memory
000 200 000	= Special function not allowed
000 000 001	= Output amplitude not between 10 nV and 2V
000 000 002	= Insufficient resolution for units conversion
000 000 004	= Units conversion to volts not allowed with reference in volts
000 000 010	= Units conversion to dB not allowed with reference in volts
000 000 020	= Amplitude step not between 0 and 166 dB or 0 and 1999V
000 000 040	= Units conversion on amplitude step not allowed
000 000 100	= Amplitude step and current amplitude display not in same units

Press the [STATUS] key while the 'REJ ENTRY' indication exists to display the Reject Entry error codes.

2-35. Step Entry

The following information describes how to use the Step Entry function to change an instrument parameter. The RF OUTPUT[ON/OFF] must be enabled for the Generator to produce an output. (See the reference material on RF OUTPUT ON/OFF Entry.)

Command Syntax

Select Step Function — Enter Data — Select Units — Change Parameter

Summary

COMMAND	RANGE	RFSOLUTION	NOTES
Frequency			
Local: [FREQ][STEP]--DATA --[MHz V] -- STEP [↕]/[↔]	[kHz mV] [Hz uV]	10 Hz	
Remote: "FS"	--float--"GZ" "MZ" "KZ" "HZ"	-- "FU"/"FD"	
	0 to 520 MHz	10 Hz	1,2

Amplitude

```

Local: [AMPL][STEP]--DATA --[dB(m)] -- STEP [↑]/[↓]
      [MHz|V]
      [kHz|mV]
      [Hz|uV]
      0 to 166 dB      0.1 dB
      0 nV to 999 V  3 digits

Remote: "LS"      --float--"dB"      -- "LU"/"LD"
      "V"
      "mV"
      "uV"
      "nV"
      0 to 166 dB      0.1 dB      1,2,3
      0 nV to 999V    3 digits      1,2,3
    
```

FM deviation

```

Local: [FM][STEP] --DATA --[MHz|V] -- STEP [↑]/[↓]
      [kHz|mV]
      [Hz|uV]
      0 to 500 kHz    3 digits

Remote: "DS"      --float--"G7"      -- "DU"/"DD"
      "mZ"
      "kZ"
      "hZ"
      0 to 500 kHz    3 digits      1,2,3
    
```

AM depth

```

Local: [AM][STEP] --DATA --[%]      -- STEP [↑]/[↓]
      0 to 99%      1%

Remote: "PS"      --float--"PC"      -- "PU"/"PD"
      0 to 99%      1%      1,2,3
    
```

Example

Recall the Instrument Preset State: [RCL][9][8]. Step the displayed frequency of 300 MHz, in 10-MHz steps, to 270 MHz.

```

Local: [FREQ] [STEP] [1] [0] [MHz|V] [↓] [↓] [↓]STEP
Remote: "FS10MZ,FD,FD,FD"
    
```

Notes

1. float equals floating-point number.
2. Entering the step size from IEEE-488 does not select the step function. For example, "FS10MZ" does not select the step function. "FD" or "FU" must be used to select the frequency step function. The generic step up/down commands "SU" and "SD" may be used to step the current step function.
3. Only frequency step entries are allowed when in the meter mode of operation.

Related Operations

Relative Function

2-36. REMOTE OPERATION (IEEE-488 INTERFACE)

The following paragraphs describe how to operate the Generator using the IEEE-488 Interface. This interface allows you to program the Generator and operate instrument functions via the IEEE-488 bus (with the exception of the front panel POWER switch and the rear panel REF INT/EXT switch). The IEEE-488 Interface also provides additional programming features not accessible from the front panel.

The rest of this section is divided into two parts: the first part describes how to set up the Generator for operation on the IEEE-488 bus and gives some typical programming examples. The first part also includes a complete list of the programming commands recognized by the Generator.

The second part describes the implementation of the IEEE-488 interface and programming features that are accessible only from the IEEE-488 Interface. The second part includes typical timing data, provided as an aid to system programmers. This information can assist in writing programs that have greater speed and efficiency.

The Generator can be used with any IEEE-488 controller in the normal addressed mode. The following two additional modes are available for operation without a controller:

Listen-only mode
Talk-only mode

In the listen-only mode, the Generator responds to all data messages on the IEEE-488 bus. In the talk-only mode, the Generator sends commands on the IEEE-488 bus to program another 6060A/AN Generator (or a Fluke 6070A/6071A, with some restriction a Fluke 6060A).

2-37. Setting Up the IEEE-488 Interface

Figure 2-5 shows a 6060A/AN Signal Generator connected to a Fluke 1722A via the IEEE-488 bus. Use the following procedure to set up the Generator for IEEE-488 operation:

1. Connect a standard IEEE-488 cable between the Generator and the IEEE-488 device.

NOTE

When using an IEEE-488 cable with a metallic hood, the IEEE-488 Interface signal SHIELD (pin 12) can be disconnected from instrument ground. To do this, use the left-most address switch (as viewed from the rear panel).

2. Select the IEEE-488 address and mode as follows:
 - a. To control the Generator with a controller, set both the LISTEN ONLY and TALK ONLY switches to 0 (down). Set switches a1 through a5 to the desired address 0 through 30. For example, for an address of 1, set switches a2, a3, a4, and a5 to 0 (down), and set switch a1 to 1 (up).
 - b. For talk-only operation, set the TALK ONLY switch to 1 (up).
 - c. For listen-only operation, set the LISTEN ONLY switch to 1 (up) and the TALK ONLY switch to 0 (down).
3. Verify the address and mode:
 - a. Press the [SPCL] and the [1][0] keys. Verify that the selected address appears in decimal in the Frequency display field.
 - b. If the talk-only mode or listen-only mode has been selected, "to" or "lo" appears to the left of the address in the Frequency display field.

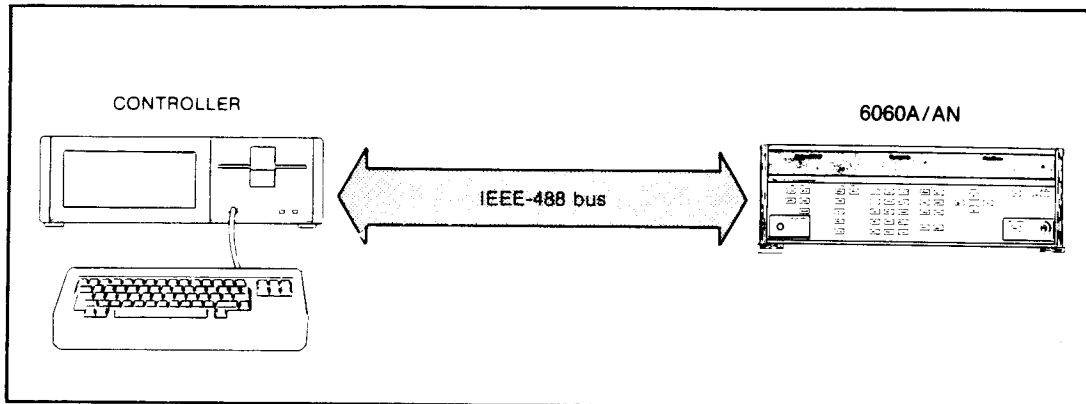

Figure 2-5. 6060A/AN Signal Generator Connected to a 1722A

NOTE

The address switches are continuously monitored except when in remote. The TALK ONLY and LISTEN ONLY switches are only read when the Generator is powered on.

2-38. Programming Commands

After the address and mode have been set, the Generator can be programmed by an IEEE-488 controller or from another Generator. Tables 2-7 and 2-8 and the programming examples following them provide the basic information on how to program the Generator.

More details about the commands can be found in two places. Commands that are available from the front panel are described in the first part of this section. Those commands that are only available from the IEEE-488 Interface are described in the Commands Descriptions paragraphs later in this section of the manual.

Table 2-7 is an index for the IEEE-488 commands used in Table 2-8. This index is a list of the command headers according to function. Table 2-8 lists all the remote commands that are recognized by the Generator. The commands are listed alphabetically by function.

Table 2-7. Index of IEEE-488 Commands

FUNCTION	COMMAND HEADERS
Amplitude Entry	AP, SP3x, RA, SP8x, SP9x
Binary Learn Commands	LI, LM
Clear Commands	CB, CE, CL
Edit Entry	AB, DB, FB, PB, KB, KA, KD, KF, KP
Frequency Entry	FR, SP2x, RF
Interface Mode Commands	EM, RM, TM, VM, UM, @
Interrogate Commands	ID, IE, II, IO, IR, IT, IU, IV
Memory Entry	RC, ST, SQ
Meter Entry	DR, PK, SP6x, XM
Modulation Entry	AM, AE, AI, FM, FE, FI, MR, MF
Monitor Commands	IB, OB, OD, RB, RW, DW, WB, WW, XA, XB, XD, XR
RF ON/OFF Entry	RO
Special Function Entry	SP
SRQ Commands	IM, SM, XF
Step Entry	FS, LS, PS, DS, SU, SD, FU, FD, LU, LD, PU, PD, DU, DD
Trigger Commands	CT, TR

Table 2-8. IEEE-488 Commands

COMMAND USE	COMMAND			COMMENTS
	HEADER	NUMERIC	SUFFIX	
AMPLITUDE ENTRY				
Program Amplitude	AP	float	V MV UV NV DB	Programs displayed amplitude in units of: volts millivolts microvolts nanovolts dB or dBm
Convert Amplitude Units	AP	none	V MV UV NV DB	Changes amplitude units to: volts volts volts volts dB or dBm
Relative Amplitude	SP	30/31	none	Disables/enables relative amplitude operation
Relative Amplitude	RA	0/1		Alternate programming command for disable/enable relative amplitude operation.
Level Correction	SP	80 81 82	none	Enables all level correction. Disables all level correction. Disables attenuator correction.
Amplitude Fixed Range	SP	90/91	none	Disables/enables amplitude fixed-range operation.
BINARY LEARN COMMANDS				
Store a Front Panel Setup	LI	int	string	The Generator stores the string into the memory location specified by int. See the Command Description paragraph for decoding the learn string.
Send a Front Panel Setup	LM	int	none	The Generator responds with the contents of the memory location specified by int. See the Command Descriptions paragraph for decoding the learn string.
CLEAR COMMANDS				
Clear IEEE-488 Output Buffer	CB	none	none	Clears IEEE-488 output buffer.
Clear error	CE	none	none	Clears the IEEE-488 rejected entry status.
Device Clear	CL	none	none	Clears the instrument state.

Table 2-8. IEEE-488 Commands (cont)

EDIT ENTRY				
Position Amplitude Bright Digit	AB	float	V MV UV NV DB	Positions the bright digit in the AMPLITUDE display with the stated resolution. For example, enter "AB10MV" for a 10-mV resolution.
Position FM Bright Digit	DB	float	GZ MZ KZ HZ	Positions the bright digit in the FM display with the stated resolution. For example, enter "DB1KZ" for a 1-kHz resolution.
Position Frequency Bright Digit	FB	float	GZ MZ KZ HZ	Positions the bright digit in the FREQUENCY display with the stated resolution. For example, enter "FB1MZ" for a 1-MHz resolution.
Position AM Bright Digit	PB	float	PC	Positions the bright digit in the AM display with the stated resolution. For example, enter "PB1PC" for a 1% resolution.
Edit	KB	float	none	Edits the current bright digit by float counts.
Edit Amplitude	KA	float	none	Moves the bright digit to the AMPLITUDE display and edits amplitude by float counts.
Edit FM	KD	float	none	Moves the bright digit to the FM display and edits FM by float counts.
Edit Frequency	KF	float	none	Moves the bright digit to the FREQUENCY display and edits frequency by float counts.
Edit AM	KP	float	none	Moves the bright digit to the AM display and edits AM by float counts.
FREQUENCY ENTRY				
Frequency Programming	FR	float	GZ MZ KZ HZ	Programs displayed frequency in units of: gigahertz megahertz kilohertz hertz
Relative Frequency	SP	20/21	none	Disables/enables relative frequency operation.
Relative Frequency	RF	0/1	none	Alternate programming command for disable/enable relative frequency operation.
INTERFACE MODE COMMANDS				
Error Mode	EM	0/1	none	Disables/enables the clear error mode. If disabled, the IEEE-488 error status is cleared only when interrogated. If enabled, the error status is cleared when a new message is processed.

Table 2-8. IEEE-488 Commands (cont)

Record Mode	RM	0/1	none	Disables/enables the record mode. If disabled, the message unit is a command. If enabled, a message unit is a record. The message unit is the smallest group of characters that the Generator processes.
Record Terminator Mode	TM	0/1	none	Selects the LF/CR character as the record terminator. The record terminator is used on input in the record mode and is sent following all output.
Output Valid Mode	VM	0/1	none	Disables/enables the output valid mode. In the output valid mode, the Generator waits to process commands until the RF output has become valid.
Unbuffered Mode	UM	0/1	none	Disables/enables the unbuffered mode. If disabled, all input is buffered. If enabled, only one message unit is buffered.
"@" Modes	@	int	none	The "@" command may be used as an alternate method of programming interface modes.
INTERROGATE COMMANDS				
Instrument Identification	ID	none	none	The Generator responds with its model number, for example, "6060A/AN".
Deviation Reading	IF	none	none	Interrogates the FM deviation meter reading. See Deviation Meter Entry paragraphs for details.
Interface Modes	II	none	none	Interrogates the interface modes selected. The Generator responds with an unsigned integer.
Option Loading	IO	none	none	Interrogates the option loading. The Generator responds with the message: "5,0,1".
Rejected Entry	IR	none	none	Interrogates the rejected entry error codes. The Generator responds with three octal fields: "AAAAA,BBBBB,CCCCC". See Table 2-6 for a list of rejected entry error codes.
Self Test	IT	none	none	Interrogates the results of the self tests. The Generator responds with the self-test results. See paragraph 4D-20 for self-test codes.

Table 2-8. IEEE-488 Commands (cont)

UNCAL	IU	none	none	Interrogates the uncalibrated output error codes. The Generator responds with three octal fields: "AAAAA,BBBBB,CCCCC". See Table 2-5 for a list of uncal error codes.
Software Version	IV	none	none	Interrogates the software version. The Generator responds with the status message: "Vxx.x" where x's are decimal digits representing the current software revision level.
MEMORY ENTRY				
Recall	RC	int	none	Recalls the front panel setup stored at the memory location specified by int.
Store	ST	int	none	Stores the current front panel setup at the memory location specified by int.
Sequence	SQ	none	none	Sequences to (recalls) the next higher memory location.
METER ENTRY				
Range	DR	0/1	none	Selects 500/50 kHz deviation range for meter mode operation.
Peak	PK	0/1	none	Selects positive/negative peak for meter mode operation.
On/off	SP	60/61	none	Disables/enables the meter mode operation.
MODULATION ENTRY				
Program AM	AM	float	PC	Programs AM depth in percent.
External AM	AE	0/1	none	Disables/enables external AM modulation.
Internal AM	AI	0/1	none	Disables/enables internal AM modulation.
Program FM	FM	float	GZ MZ KZ HZ	Programs FM deviation in units of: gigahertz megahertz kilohertz hertz
External FM	FE	0/1	none	Disables/enables external FM modulation.
Internal FM	FI	0/1	none	Disables/enables internal FM modulation.

Table 2-8. IEEE-488 Commands (cont)

Program Mod Freq	MR	0/1	none	Programs modulation frequency to 400 Hz/1000 Hz.
Program Mod Freq	MF	float	GZ MZ KZ HZ	Programs modulation frequency in units of: gigahertz megahertz kilohertz hertz
MONITOR COMMANDS				
Input Bit	IB	none	BIT Designator	Responds with the value of the designated hardware bit.
Output Bit	OB	0/1	BIT Designator	Sets the designated hardware bit to 0 or 1.
Output Dac	OD	int	DAC Designator	Sets the value of the designated hardware DAC to the value specified by int.
Read Byte	RB	int	none	Reads the value of the addressed byte. The Generator responds with an unsigned integer.
Read Word	RW	int	none	Reads the value of the addressed word. The Generator responds with an unsigned integer.
Define Write Address	DW	int	none	Defines the address to be used by the write byte/word commands.
Write Byte	WB	int	none	Writes int into the address specified with the define write address command.
Write Word	WW	int	none	Writes int into the address specified with the define write address command.
Read Attenuation	XA	none	none	Reads the current attenuation. The Generator responds with an unsigned integer.
Write Attenuation	XB	none	none	Changes attenuation to 6 dB times the unsigned integer. The integer can be 0 to 23.
Set Frequency Direct	XD	float	GZ MZ KZ HZ	Sets the frequency hardware directly to the specified synthesizer frequency.
Read Deviation Meter Direct	XM	none	none	Reads the current deviation meter (A/D) value. The Generator responds with an unsigned integer.

Table 2-8. IEEE-488 Commands (cont)

RF Output	XR	0/1	none	"XR0" programs all attenuation. "XR1" restores attenuation to its previous state.
RF ON/OFF ENTRY				
RF Output	RO	0/1	none	Turns RF output off/on.
SPECIAL FUNCTION ENTRY				
Special Functions	SP	00 02 03 04 07/08 09 10 11 12/13 14 15 20/21 30/31 60/61 70 71 72 80 81 82 83-86 90/91		Clears all special functions Initiates self test Display check Key check Set/reset SRQ Displays S/W rev and instr ID Displays IEEE-488 address Displays self-test results Turns display on/off Initializes memory Latch test Disables/enables relative freq Disables/enables relative ampl Disables/enables meter mode Medium key repeat rate Fast key repeat rate Slow key repeat rate Enables all level correction Disables all level correction Disables attenuator correction Programs alternate 24dB attens Disable/enables ampl fixed ring
SRQ COMMANDS				
Interrogate SRQ Mask	IM	none	none	Interrogates the SRQ mask. The Generator responds with the decimal value of the SRQ mask.
Set SRQ	SM	int	none	The SRQ mask is set to int.
Local Operation Alert Mode	XF	0/1	none	Disables/enables a mode to set SRQ each time a local entry is made. This SRQ is enabled by setting the front panel bit in the SRQ mask.
STEP ENTRY				
Program FREQ STEP Size	FS	float	GZ MZ KZ HZ	Programs frequency step size in units of: gigahertz megahertz kilohertz hertz
Program AMPL STEP Size	LS	float	V MV UV NV DB	Programs amplitude step size in units of: volts millivolts microvolts nanovolts dB or dBm

Table 2-8. IEEE-488 Commands (cont)

Program AM STEP Size	PS	float	PC	Programs AM step size in percent.
Program FM STEP Size	DS	float	GZ MZ KZ HZ	Programs FM step size in units of: gigahertz megahertz kilohertz hertz
Step Up/Down	SU/SD	none	none	Steps the currently selected step function up/down one step.
Step Up/Down Frequency	FU/FD	none	none	Changes the current step function to frequency and steps frequency up/down one step.
Step Up/Down Amplitude	LU/LD	none	none	Changes the current step function to amplitude and steps amplitude up/down one step.
Step Up/Down AM	PU/PD	none	none	Changes the current step function to AM and steps AM up/down one step.
Step Up/Down FM	DU/DD	none	none	Changes the current step function to FM and steps FM up/down one step.
TRIGGER COMMANDS				
Configure Trigger	CT	string	none	Configures the trigger. Each time a trigger command or a group execute trigger interface message is received, the Generator executes the string of commands. The string record must end with a record terminator.
Trigger	TR	none	none	Trigger command. Equivalent to the group execute interface message. Upon processing the trigger command, the Generator executes the string, which has been preprogrammed with the configure trigger command.

2-39. Programming Examples

The following three examples show how to use the IEEE-488 bus and use a variety of controllers to program the Generator. In the first example, a Fluke 1722A Controller is used to program the Generator. In the second example, two Generators are configured to track each other in frequency. In the third example, a 1722A is used to program the Generator with the frequency step up controlled by the trigger command.

2-40. PROGRAMMING EXAMPLE 1

Use the following procedure to program the Generator with a Fluke 1722A Instrument Controller to this state:

Frequency	210 MHz
Amplitude	6 dBm
Modulation Freq.	1000 Hz
FM	5 kHz
Internal FM	ON
AM	15%
External AM	ON

1. Connect the Generator to the Controller with an IEEE-488 cable.
2. Set the address switch of the Generator as follows (as viewed from the rear of the instrument):

00000010

3. Enter the following program into the Controller:

```

1  ! Fluke 1722A BASIC program to control a 6060A/AN.
2  ! The Address of the 6060A/AN is 2.
3  AX = 2%
10 ! Clear the 6060A/AN so that it is in a known state.
15 INIT PORT 0
20 REMOTE @AX \ CLEAR @AX
100 ! SFT THE 6060A/AN.
110 PRINT @AX, "FR210MZ,AP6DB,MR1,FM5KZ,FI1,AM15PC,AE1"
999 END
    
```

4. Run the program by typing on the Controller "RUN <RETURN>".

2-41. PROGRAMMING EXAMPLE 2

The 6060A/AN Signal Generator can be connected to another 6060A/AN Signal Generator in a master-slave configuration. In the following example, two Generators are configured to track each other in frequency. This configuration may be used to track frequency, amplitude, AM, or FM.

1. Connect two 6060A/AN Signal Generators together with an IEEE-488 cable.
2. Set the rear panel address switch of the first Generator (talker) as follows:

00100000

3. Set the rear panel address switch of the second Generator (listener) as follows:

01000000

4. Manually program the talker Generator as follows:

FUNCTION	VALUE	KEY SEQUENCE
Frequency	210 MHz	[FREQ] [2] [1] [0] [MHz V]
Function	Frequency	[FREQ] [STEP]
Step	1.25 kHz	[1] [.] [2] [5] [kHz mV]

5. Manually program the listener Generator as follows:

FUNCTION	VALUE	KEY SEQUENCE
Frequency	195 MHz	[FREQ] [1] [9] [5] [MHz V]
Step Function	Frequency	[FREQ] [STEP]
Frequency Step	1.25 kHz	[1] [.] [2] [5] [kHz mV]

6. On the talker Generator, press the [↑]STEP or [↓]STEP keys. Each time the key is pressed, the frequency of both Generators increases or decreases by 1.25 kHz (the Frequency Step) at frequencies 15 MHz apart.

Different functions on each Generator can be programmed to track in the master-slave configuration. In other words, while the master Generator can be programmed to step increase 25 kHz FM, the Slave Generator can be programmed to step 25% AM.

NOTE

To use the step function feature for other functions, change the step function on the Generators to the desired functions.

2-42. PROGRAMMING EXAMPLE 3

In the following example, the Generator is programmed by a Fluke 1722A Controller (via the IEEE-488 bus) to the same state as that shown in Programming Example 1. Additionally, the frequency step size is set to 1.25 kHz, and the trigger buffer is programmed to execute the step up command when the trigger command is received. The SRQ mask of the Generator is set to generate an SRQ when the RF output has settled and the Generator is ready for more input from the bus.

The program then enters a loop where it waits for the ready SRQ, sends the GET (group execute trigger) interface message to step up the frequency, and waits again. At this time you should do the following:

1. Connect the Generator to the Controller with an IEEE-488 cable.
2. Set the rear panel address switch of the Generator as follows:

00000111

3. Enter the following program into the Controller:

```

1  ! Fluke 1722A BASIC program to control a 6060A/AN.
2  ! The address of the 6060A/AN is 7.
3  A% = 7%
10 ! Clear the 6060A/AN so that it is in a known state.
15 INIT PORT 0
20 REMOTE @A% \ CLEAR @A%
100 ! Set the 6060A/AN.
110 PRINT @A%, "FR210MZ,AP6DB,MR1,FMSKZ,FI1,AM15PC,AE1"
120 ! Set the frequency step, output valid mode,
121 ! and configure the trigger buffer.
130 PRINT @A%, "FS1.25KZ,VM1,CTSU"
140 ! Set the SRQ mask to enable "output valid" SRQ
150 PRINT @A%, "SM16"
160 ! Wait for above commands to finish processing
170 WAIT 1000 \ S% = SPL (A%)
180 ! Trigger the first step up
190 TRIG @A%
300 ! Wait for SRQ
310 ON SRQ GOTO 800
320 WAIT FOR SRQ
800 OFF SRQ
810 ! Check the serial poll response
820 S% = SPL(A%)
830 IF (S% AND 64%+16%) <> 80% THEN PRINT s%;" Bad Serial Poll Response"
840 ! Trigger the next step up
850 TRIG @A%
860 ! Resume operation-- waiting for next SRQ
870 RESUMF 300
999 END

```

4. Run the program by typing on the Controller "RUN <RETURN>".

2-43. Interface Functions

The Generator implements a subset of interface functions defined by the IEEE Standard 488-1978. Table 2-9 summarizes the interface functions implemented. This section describes the operation of the Generator in response to interface messages associated with each interface function.

2-44. Address Mode

In the address mode, the Generator may be operated from local (using the Front Panel keys) or from remote (using the IEEE-488 Interface). The following paragraphs describe the operation of the Generator in both states and transitions between the states.

The available IEEE-488 messages and their descriptions for the address mode of operation are presented in Table 2-10.

2-45. LOCAL OPERATION

The Generator powers up in the local mode. When in local mode, the following conditions are present:

The front panel REM indicator is not lit.

Device trigger (GET), device clear (DCL), and selected device clear (SDC) interface messages are ignored.

All device dependent messages are ignored.

If the data output was requested while the Generator was in the remote mode, the data output of a talker may be sent.

2-46. GOING FROM LOCAL TO REMOTE

The Generator switches from local to remote when the "my listen address" message (MLA) is received, and the Remote Enable (REN) signal is true.

Table 2-9. IEEE-488 Interface Function List

FUNCTION	DESCRIPTION
SH1	Complete source handshake capability
AH1	Complete acceptor handshake capability
T5	Basic talker, Talk only, Serial poll, Unaddressed if MLA
TE0	No extended talker capability
L3	Basic listener, Listen only, Unaddressed if MTA
LE0	No extended listener capability
SR1	Complete service request capability
RL1	Complete remote/local capability
PP0	No parallel poll capability
DC1	Complete device clear capability
DT1	Complete device trigger capability
CO	No controller capability
E1	Open Collector drivers

Table 2-10. IEEE-488 Address Mode Message Descriptions

MESSAGE	DESCRIPTION
<p>pon Power-On</p> <p>Talker Operation</p> <p>Listener Operation</p> <p>Service Request Operation</p>	<p>When powered up, the Generator generates a Power-On message (pon) and clears its output buffer. The Generator is not addressed to talk when the power is turned on.</p> <p>The Generator is not addressed to listen when the power is turned on.</p> <p>The Service Request (SRQ) signal is always false when the power is turned on. The power-on value of the SRQ mask is 192.</p>
<p>MTA My Talk Address</p> <p>Talker Operation</p> <p>Listener Operation</p>	<p>The Generator is addressed to talk upon receipt of the MTA message. The front panel 'ADDR' indicator is lit while the Generator is addressed to talk.</p> <p>The Generator unlistens when the MTA message is received.</p>
<p>MLA My Listen Address</p> <p>Talker Operation</p> <p>Listener Operation</p>	<p>The Generator untalks when the MLA message is received.</p> <p>The Generator is addressed to listen when the MLA message is received. The front panel 'ADDR' indicator of the Generator is lit while the Generator is addressed to listen.</p>
<p>Data</p> <p>Talker Operation</p> <p>Listener Operation</p>	<p>The Generator sends data to the IEEE-488 bus only when requested by a programming data message. Message formats are described in the Command Description paragraphs. An End of Record (EOR) character is sent with EOI asserted following all outputs. The EOR character is either a carriage return or a line feed, depending on the setting of the terminator mode. The parity bit is always zero. Multiple output requests are buffered until the buffer is full. Processing of programming data messages is stopped until the buffer is no longer full. The buffer can be cleared with the Clear Buffer command ("CB"). The buffer is also cleared on power up (pon), with a Clear Command ("CL"), or with a Device Clear interface message (DCL or SDC).</p> <p>Command syntax, error processing, and input buffer overflow are described in the paragraphs on Command Processing. Refer to Table 2-8 for a list of IEEE-488 commands that are recognized by the Generator.</p>

Table 2-10. IEEE-488 Address Mode Message Descriptions (cont)

MESSAGE	DESCRIPTION
IFC Interface Clear	
Talker Operation	The Generator untalks and unlistens when the IFC message is received.
Listener Operation	The Generator unlistens and untalks when the IFC message is received.
OTA Other Talk Address	
Talker Operation	The Generator untalks when the OTA message is received.
SPE Serial Poll Enable	
Talker Operation	After receiving the SPE message, the Generator responds with the serial poll status byte, if addressed to talk.
SPD Serial Poll Disable	
Talker Operation	After receiving the SPD message, the Generator resumes normal talk operation.
ULA Unlisten Address	
Listener Operation	The Generator unlistens when the ULA message is received.
RSV Request Service	
Service Operation	The front panel SRQ indicator is lit when the rsv message is sent. The Generator may request service for several reasons. Each reason for service request can be individually masked with the set mask command ("SM"). The service request mask can be interrogated with the interrogate mask command ("IM").
DCL Device Clear	
Clear Operation	The DCL message is ignored when in local. When the DCL message is received (during remote operation) the Generator is cleared. Any characters in the input buffer are cleared followed by the same operation as the clear command ("CL"). The operation of the DCL message is identical to the operation of the selected device clear (SDC) message. The cleared state of the Generator is described in the paragraphs on Power-On Conditions.
SDC Selected Device Clear	
Clear Operation	The SDC message is ignored during local operation. When the SDC message is received (during remote operation), the Generator is cleared. Any characters in the input buffer are cleared followed by the same operation as the clear command ("CL"). The operation of the SDC message is identical to the operation of the device clear (DCL) message. The cleared state of the Generator is described in the paragraphs on Power-On Conditions.

Table 2-10. IEEE-488 Address Mode Message Descriptions (cont)

MESSAGE	DESCRIPTION
GET Group Execute Trigger Trigger Operation	The GET message is ignored during local operation. When the GET message is received (during remote operation), the Generator executes a command string that has been preprogrammed with the Configure Trigger command ("CT"). The operation of the GET message is identical to the operation of the Trigger ("TR") command.
Undefined IEEE-488 Commands	All undefined IEEE-488 commands are acknowledged by the Generator handshake sequence, but no action is taken.

2-47. REMOTE OPERATION

When in the remote mode, the following conditions are present:

The front panel REM indicator is lit.

Device trigger (GET), device clear (DCL), and selected device clear (SDC) interface messages are processed.

All device-dependent messages are processed during the remote mode.

2-48. GOING FROM REMOTE TO LOCAL

The Generator switches from remote to local mode in one of the following ways: the IEEE-488 Go To Local (GTL) message is received, the remote enable signal REN is false, or a Return To Local (rtl) message is generated by pressing the front panel [CLR|LCL] key (if the Generator is not in the local lockout mode).

The Generator enters the local lockout mode when the Local Lockout message (LLO) is received. The Generator exits the local lockout mode to the local mode when REN is false.

When switching from remote to local, unprocessed commands in the input buffer are processed until the input buffer is cleared or a front panel entry is made. Switching to local has no effect on the contents of the output buffer.

2-49. Talk-Only Mode

Figure 2-6 shows two 6060A/ANs connected together with the IEEE-488 Bus.

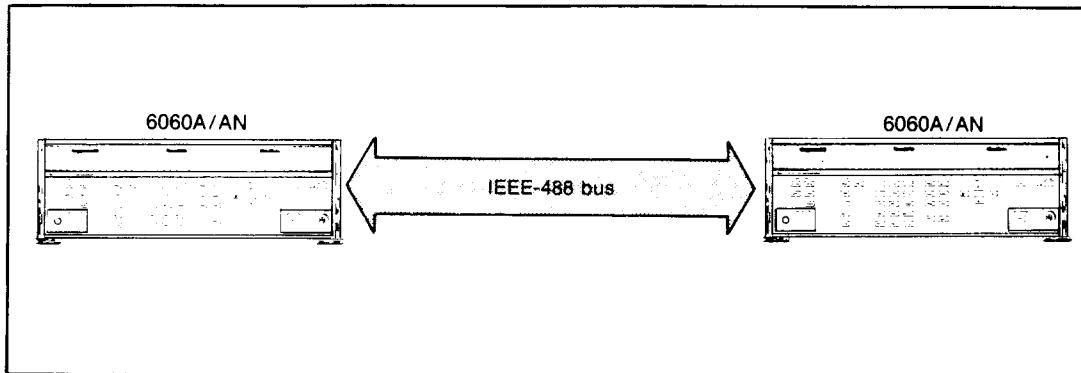

Figure 2-6. 6060A/AN Connected to Another 6060A/AN Via the IEEE-488 Bus

To select the talk-only mode, set the TALK ONLY address switch to 1 (up). If both the talk-only address switch and the listen-only address switch are set to 1, the talk-only mode is selected.

In the talk-only mode, the listener, remote/local, service request, device clear, and device trigger interface functions do not apply.

If the talk-only mode is selected, the Generator is always addressed to talk and the front panel ADDR indicator is always lit. The Step Up (“SU”) or Step Down (“SD”) message is sent when the [↑] STEP or [↓] STEP front panel keys are pressed. This output is not buffered and if no listener is connected to the IEEE-488 Interface, no output will be sent. A carriage return followed by line feed (with the EOI signal true) is always sent as the end of record.

2-50. Listen-Only Mode

To select the listen-only mode, set the LISTEN ONLY address switch to 1 (up). If both the talk-only address switch and the listen-only address switch are set to 1, the talk-only mode is selected.

If the listen-only mode is selected, the Generator is always addressed to listen, and the front panel ADDR indicator is always lit. The Generator listens and responds to all data messages on the IEEE-488 Interface. The response to data messages is the same as in the addressed mode of operation, except that requests for talker output are ignored.

In the listen-only mode, the talker, remote/local, service request, device clear, and device trigger interface functions do not apply.

2-51. Command Syntax

The Generator IEEE-488 bus commands alphabet consists of the letters A through Z (upper and lower case letters are treated equally), digits 0 through 9, and the following special characters:

@ . , ; + - CR LF

Spaces, tabs characters, and the parity bit are ignored.

INSTALLATION AND OPERATION

The IEEE-488 commands for the Generator consist of the following three parts:

Header
Numeric
Suffix

The header is always required, but the numeric and suffix may be optional. This rule gives the following four possible combinations:

⟨HEADER⟩
⟨HEADER⟩⟨NUMERIC⟩
⟨HEADER⟩⟨NUMERIC⟩⟨SUFFIX⟩
⟨HEADER⟩⟨SUFFIX⟩

Multiple commands may be separated with one of the end of string (EOS) characters “;” or “,”. Use of EOS characters facilitates recovery in the event of a syntax error and will also enhance readability.

2-52. COMMAND HEADER SYNTAX

The command header is a two alpha-character string. A list of the IEEE-488 command headers used on the Generator is presented in Table 2-8. The header determines the syntax of the numeric and suffix as listed in the table.

2-53. NUMERIC DATA SYNTAX

There are four types of numeric data: Boolean, unsigned integer, floating point, and trigger string. The following paragraphs describe each of the four numeric data types. A syntax diagram is included for each type.

1. Boolean

Boolean numeric data must be either a “0” or a “1”. All other characters will result in a syntax error.

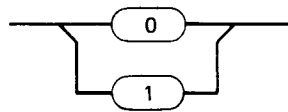

2. Unsigned Integer

Unsigned integers may be specified in decimal or in hexadecimal. Any number of decimal digits are accepted. However, values greater than 65,535 are rejected. Hexadecimal numbers are preceded by an “X”. Only 4 hexadecimal digits are accepted. Specifying a number in hexadecimal for the read word and read byte commands causes the response to be sent in hexadecimal. Decimal digits may be the numerals 0 through 9. Hexadecimal digits may be the hexadecimal digits 0 through F.

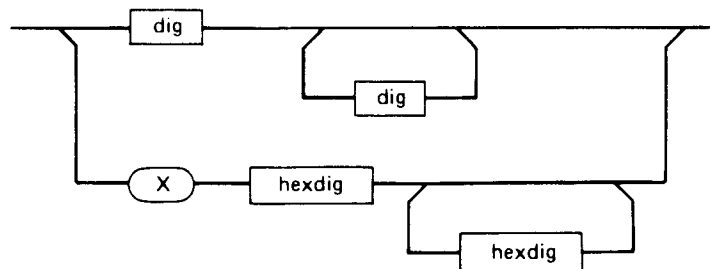

3. Floating Point

The floating-point numeric data format is the most flexible format. Digits may be the numerals 0 through 9. Any number of digits are accepted for both the number and the exponent. However, numbers greater than 2,147,483,629 are truncated, and exponents greater than 32,749 are rejected.

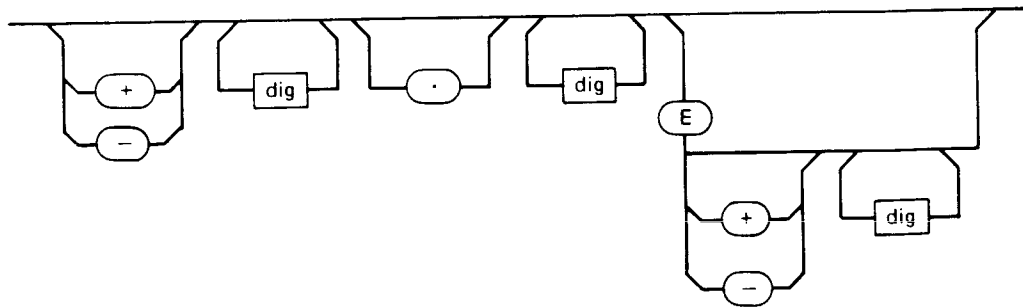

4. Trigger String

The trigger string numeric data is a string of Generator commands terminated with an EOR. The string may be up to 71 characters, not including the EOR. Commands in the string are not checked for validity until the trigger string is executed with the trigger command.

EOR is the end of record character. This character is selectable with the terminator mode command. "TM0" selects the linefeed character. "TM1" selects the carriage return character. The IEEE-488 interface signal EOI asserted with any other character is also considered an end of record.

EOS is an end of string character, use either ";" or ".,".

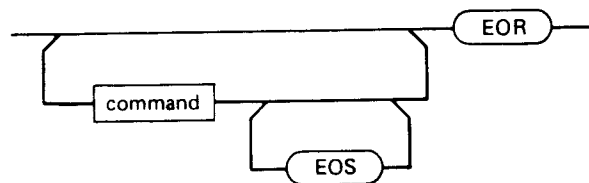

2-54. SUFFIX SYNTAX

Suffixes are always one or two alpha-characters. Certain suffixes are used to scale the numeric (the same as the front panel UNITS keys). Other suffixes mnemonically designate hardware components. The five types of suffixes are described in Table 2-11.

2-55. Command Descriptions

The following paragraphs describe the remote IEEE-488 Interface operating commands that are not accessible from the front panel of the Generator. IEEE-488 Interface commands that are accessible from the front panel of the Generator are described earlier in this section.

Table 2-11. Suffix Types

SUFFIX TYPE	SUFFIX	MNEMONIC	EQUIVALENT EXPONENT
Frequency and FM	GZ	gigahertz	9
	MZ	megahertz	6
	KZ	kilohertz	3
	HZ	hertz	0
Amplitude	V	volts	0
	MV	millivolts	-3
	UV	microvolts	-6
	NV	nanovolts	-9
	DB	dBm or dB	0
AM	PC	percent	0
DAC/BIT Designators	DAC and BIT designators are two alpha-character mnemonics that refer to hardware dacs and bits. Refer to the paragraphs on Monitor Commands for a complete list of designators.		
Learn Suffix	A Learn suffix is a string of ASCII characters that contain coded memory location contents. Refer to the paragraphs on Binary Learn Commands for decoding of the learn string.		

2-56. BINARY LEARN COMMANDS

Front panel setups are stored in the memory of the Generator in a packed binary format. The binary learn commands are used to transfer this binary data between an IEEE-488 controller and the Generator. These commands allow you to minimize the amount of programming commands needed to program the entire instrument state. The binary learn commands are:

- “LM” Learn Memory
- “LI” Learn Interface

The syntax for the Learn Memory (“LM”) command is as follows:

“LM” Memory Location Code

The Generator responds to the “LM” command with a string of 64 ASCII characters followed by an <EOR> (end of record character). This string represents the front panel settings (in a packed binary format) that were stored in the memory location specified.

NOTE

The <EOR> , end of record character, is sent with EOI asserted. “TM0” selects the linefeed character, and “TM1” selects the carriage return character.

Example

IEEE-488 Command: "LM98"

Response:

"BOABAAAAPPJMAAA KAAAAAAAAAB BOBKAAAA APECEAABPEAA
ABDAEEBBAGBLKKMPAC" (EOR)

Refer to Figure 2-7 for information on how to decode this learn string. The syntax for the Learn Interface "LI" Command is as follows:

"LI" Memory Location Code: Learn String

The Generator stores the learn string in the memory location designated by the memory location code. If the memory location specified is 99, the instrument is programmed to the data sent in the learn string.

Example

To program the Generator to the Instrument Preset State:

"LI99BOABAAAAPPJMAAA KAAAAAAAAAB BOBKAAAA AP
ECEAABPEAAABDAEEBBAGBLKKMPAC"

Note that the binary learn string in this example is the same as the learn string returned from memory location 98 which contains a record of the Instrument Preset State.

Instructions:

1. Convert the hexadecimal number to a signed decimal number as follows:
 - a. Multiply the most significant hexadecimal digit by 16.
 - b. Add the next significant digit to the value obtained in Step a.
 - c. Multiply the sum of Step b by 16, and add in the next hexadecimal digit until the least significant hexadecimal digit has been added.

NOTE

If the hexadecimal number started with an 8 through F, the number is negative. Perform Step d for negative numbers.

- d. Subtract 16 from the number raised to the power of the number of digits.

Example of Instruction 1:

To convert hexadecimal number 1E:

$$(1 * 16) + 14 = 30$$

(Since the most significant digit is 1, the number is not negative.)

INSTALLATION AND OPERATION

To convert hexadecimal number FF9C:

$$((((15 * 16) + 15) * 16) + 9) * 16 + 12 = 65436$$

(Since the most significant digit is F, the number is negative.)

Using Step d: $16^4 = 65536$, $65436 - 65536 = -100$. The signed decimal equivalent to FF9C is -100.

2. Amplitude quantities have a number and a resolution associated with them. This applies to the Displayed Amplitude, Reference Amplitude, and Amplitude Step.

Use the following procedure to identify the resolution of an amplitude quantity:

- a. If the resolution is A or B (hexadecimal), the resolution of the number is 0.1 dBm or 0.1 dB units.

Example: The Displayed Amplitude (in this figure) is -100 with a resolution of A.

- b. The actual displayed amplitude is -10.0 dBm.
- c. If the stored resolution is 0 through 9 (hexadecimal), the amplitude quantity is in volts. To convert the number to the actual amplitude in nanovolts, multiply the amplitude number by the power of ten represented by the resolution.

Example: An Amplitude Step of 12, with a resolution of 6, would be an actual amplitude step of 12,000,000 nV or 12 mV.

3. If the Relative Amplitude mode is off, the data stored in the reference amplitude location is not used.
4. If the Relative Frequency mode is off, the data stored in the reference frequency location is not used.
5. FM and FM Step quantities have a number and a resolution associated with them. To convert the number to the FM quantity in Hz, multiply the number by the power of ten represented by the resolution plus one.

Example: The FM number (in this figure) is 500, with a resolution of 100 Hz. The actual FM deviation is 50 kHz.
6. The checksum data is calculated by adding the data in the learn string, two hexadecimal digits at a time. The total, including the checksum, should add up to a number whose least significant two hexadecimal digits are 01.

NOTE

The memory location code must be an unsigned integer, indicating the memory location to be learned. Memory location 99 refers to the current instrument settings. Memory location 98 refers to the Instrument Preset State, as listed in Table 2-3.

The characters in the learn string correspond to each Generator function. A description of how to interpret the characters in the learn string is given in Figure 2-7. Table 2-12 shows the conversion from the learn string to the hexadecimal character.

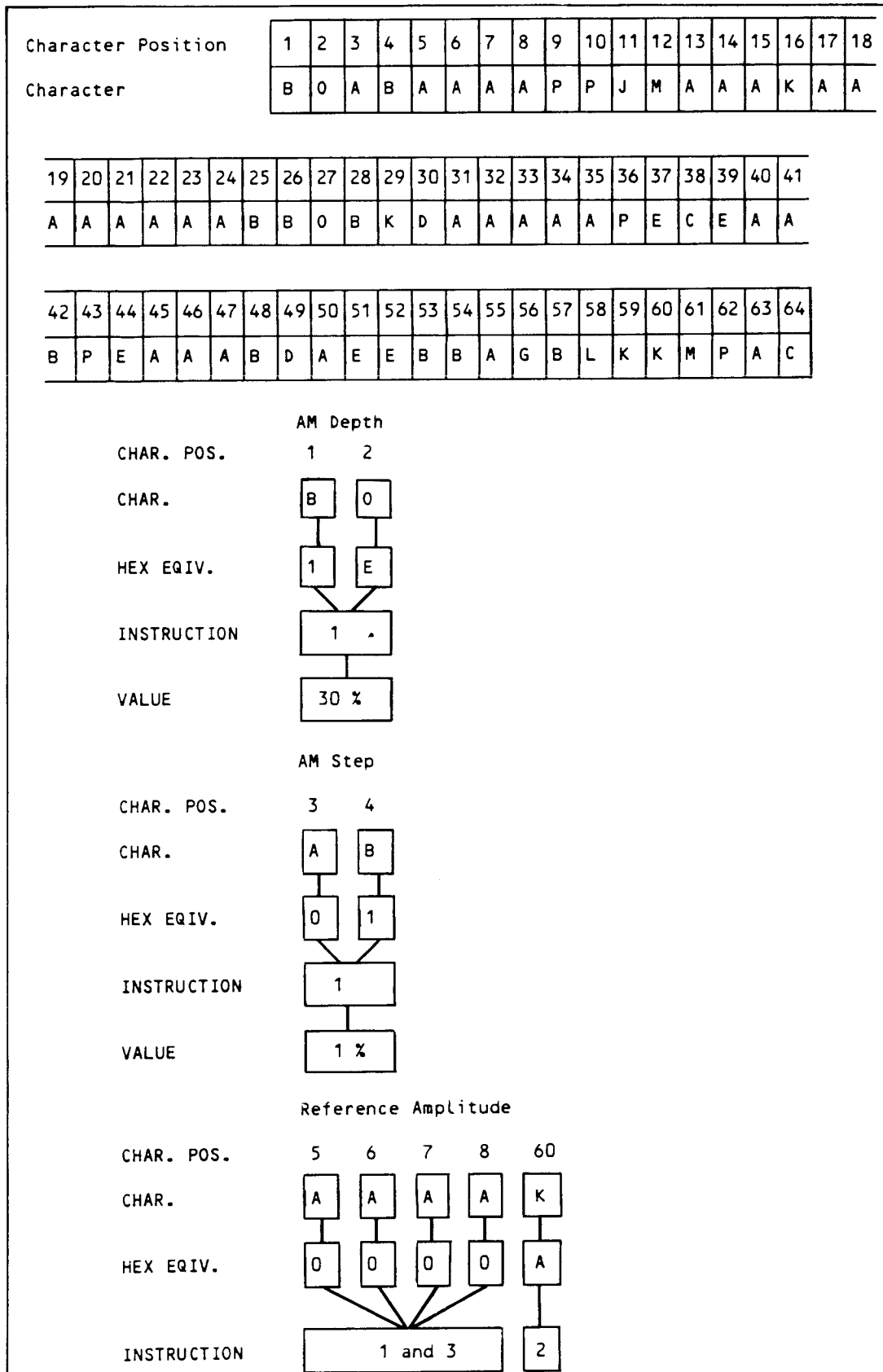

Figure 2-7. Learn String Example

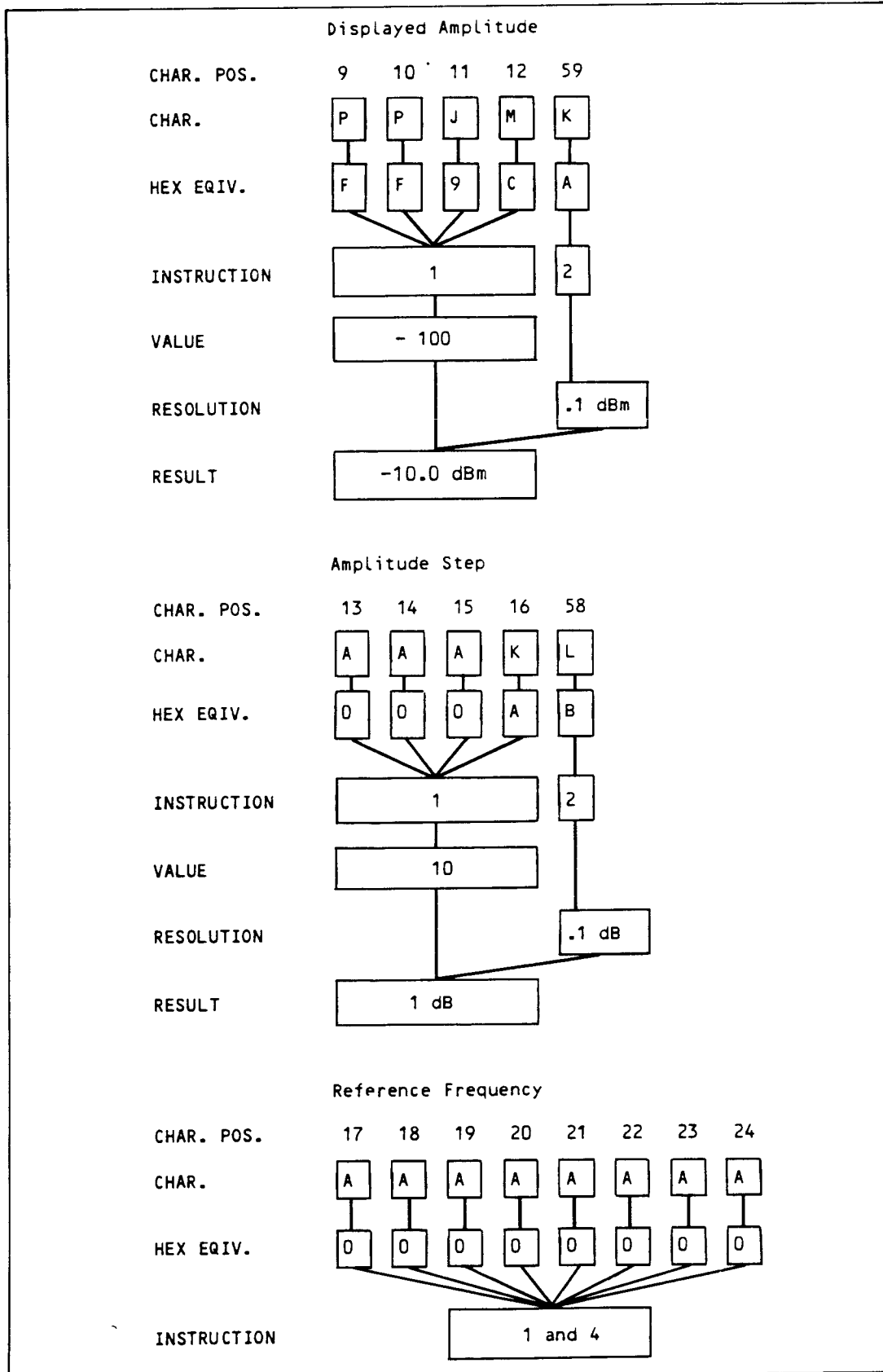

Figure 2-7. Learn String Example (cont)

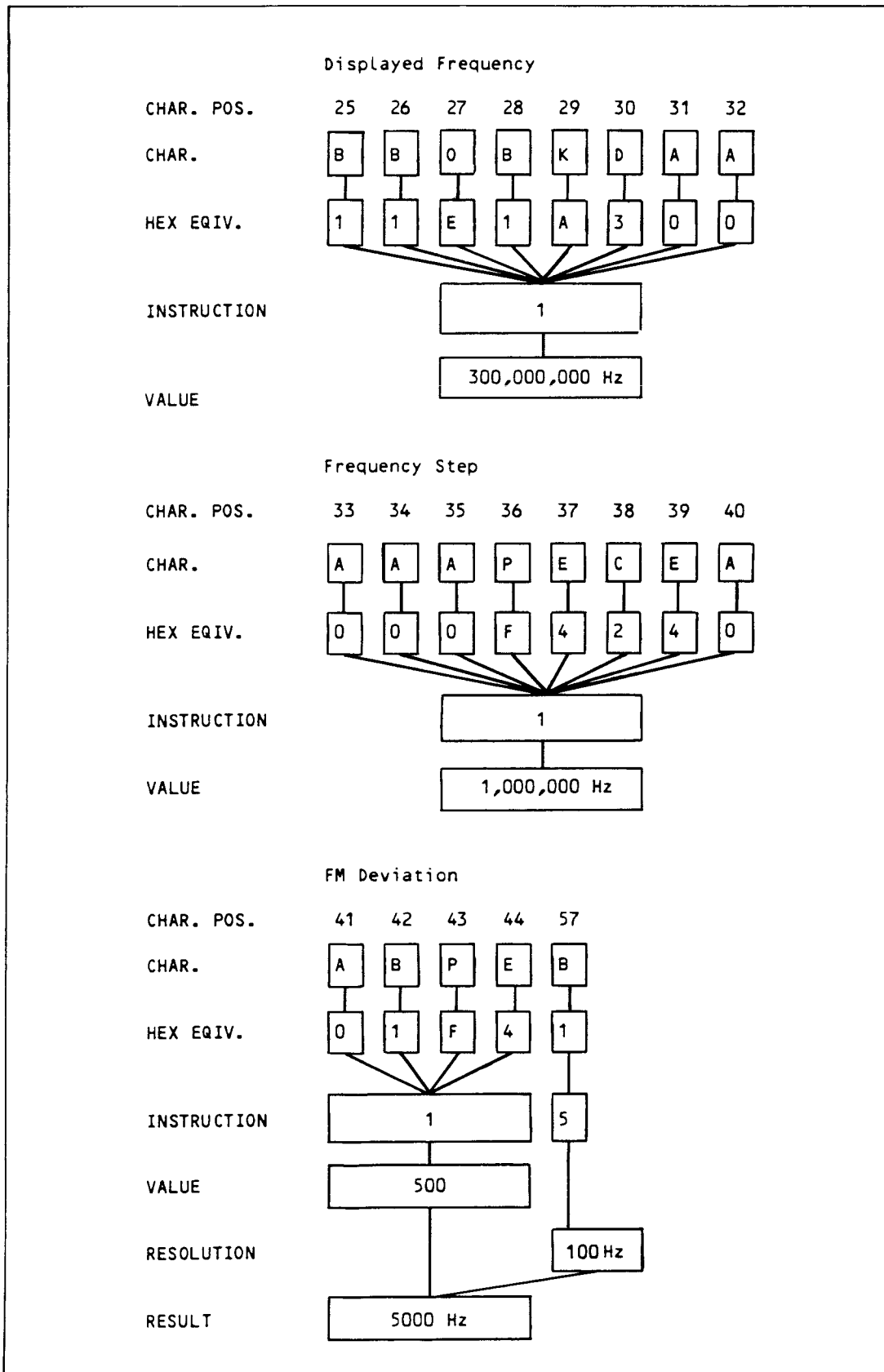

Figure 2-7. Learn String Example (cont)

INSTALLATION AND OPERATION

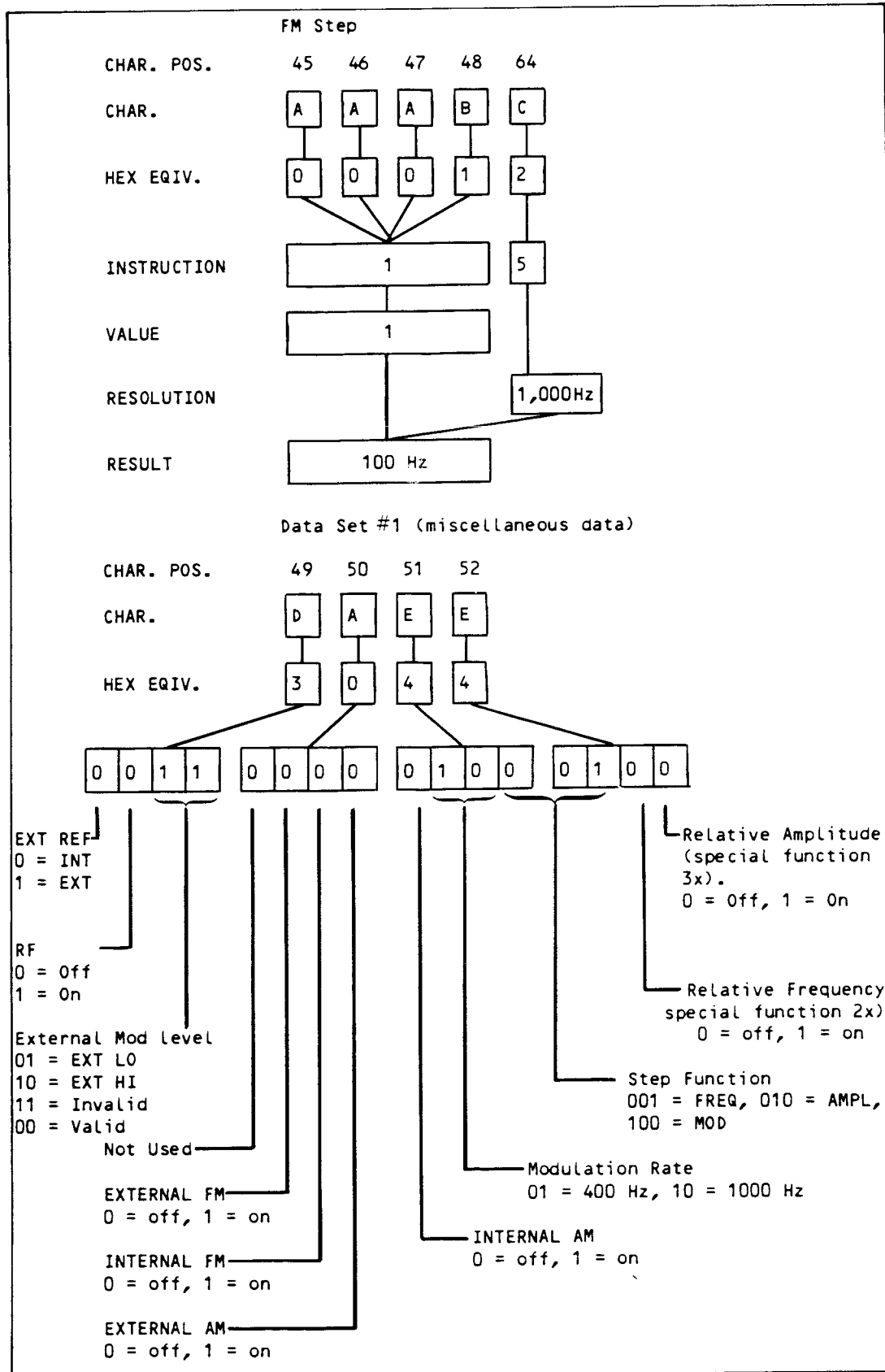

Figure 2-7. Learn String Example (cont)

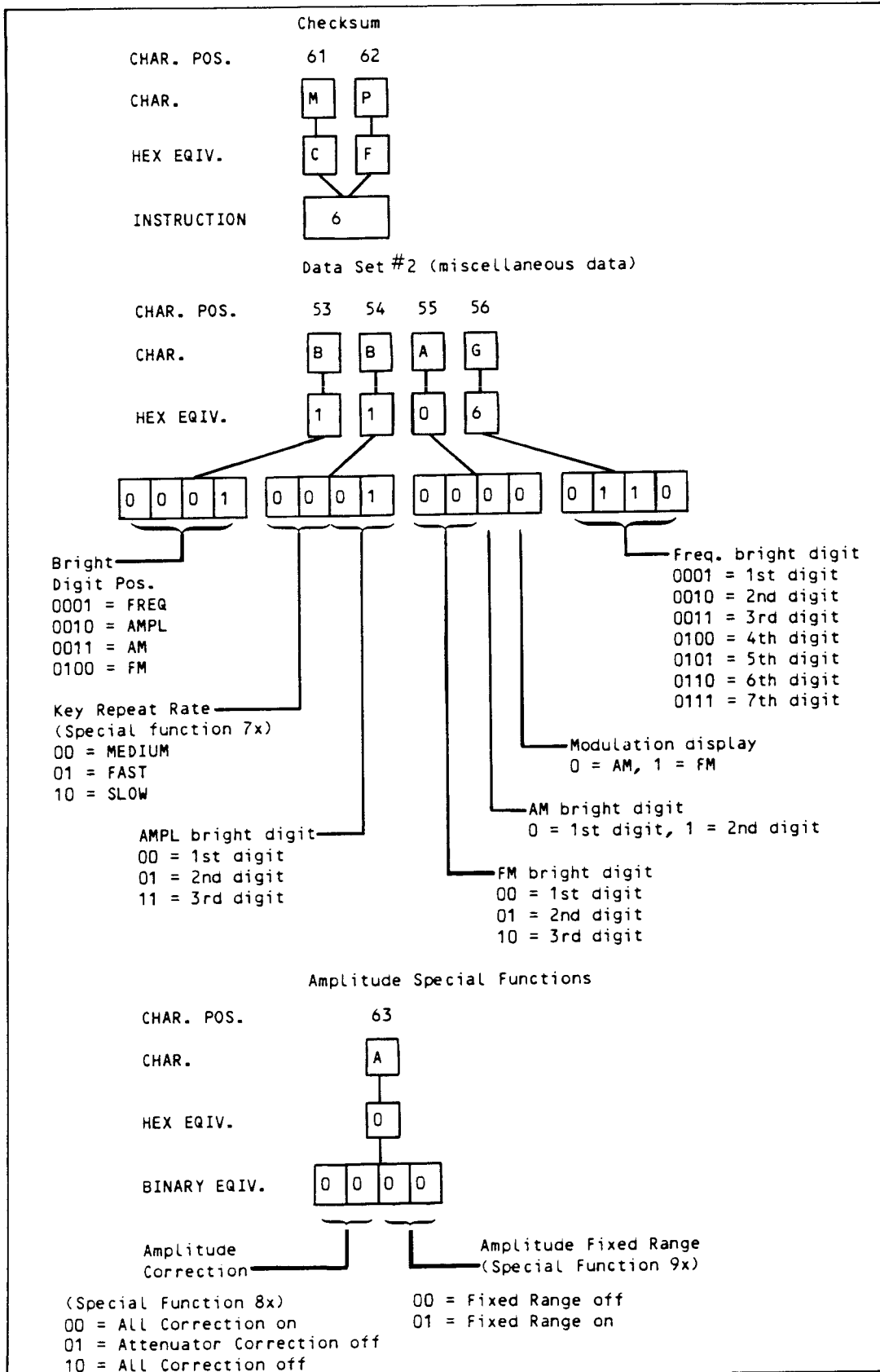

Figure 2-7. Learn String Example (cont)

Table 2-12. Learn Character to Hexadecimal Conversion

LEARN CHARACTER	HEXADECIMAL EQUIVALENT	DECIMAL EQUIVALENT
A	0	0
B	1	1
C	2	2
D	3	3
E	4	4
F	5	5
G	6	6
H	7	7
I	8	8
J	9	9
K	A	10
L	B	11
M	C	12
N	D	13
O	E	14
P	F	15

2-57. CLEAR COMMANDS

The following IEEE-488 clear commands are recognized by the Generator:

- “CB” Clear IEEE-488 input buffer
- “CE” Clear IEEE-488 rejected entry error status
- “CL” Clear instrument

The “CB” command can be used to clear the Generator output buffer. The output buffer should be cleared at the beginning of any remote program to synchronize data output. The output buffer is also cleared on power-up, with the “CL” clear Generator command, or by the SDC and DCL clear interface messages.

The “CE” command can be used to explicitly clear the error status. The error status is also cleared when it is interrogated with the “IR” command, or the “CL” clear Generator command, or the SDC and DCL clear.

The “CL” command is used to clear the instrument state. The same actions are performed with the SDC and DCL clear interface messages. (In addition, the input buffer is cleared with the clear interface messages.) The following IEEE-488 commands are performed with the clear Generator command: “RC98, ROI, CE, CB, RM0, TM0, EM0, VM0, UM0, SM192, SP08, XF0, DW0, DR0, PK0, CT” (EOR) .

2-58. INTERFACE MODE COMMANDS

Interface Mode commands are used to configure the Generator for different modes of IEEE-488 interface operation. Since the Generator knows when its RF output has settled, it can be configured to synchronize itself with the Controller. This eliminates WAIT statements in the program, which are normally used to allow time for the output of the controlled device to settle. Table 2-13 lists the Interface Mode Commands.

The error mode selects when the IEEE-488 rejected entry status is cleared. If turned on, the error status is cleared when a new message is processed. If turned off, the status is cleared only when interrogated with the “IR” (interrogate rejected entry) command or when explicitly cleared with the “CE” (clear error command).

The record mode selects whether the message unit is a record or a command. When turned on, the message unit is a record. When turned off, the message unit is a command.

The terminator mode selects the character used as the record terminator. The terminator character is not used for command processing unless the record mode is enabled. When turned on, the record terminator CR (carriage return) is used. When turned off, the record terminator LF (line feed) is used. The record terminator character is the last character in all IEEE-488 messages sent from the Generator.

The unbuffered mode selects when messages from the IEEE-488 interface are processed. When turned on, messages are read from the IEEE-488 interface only when the microprocessor is ready to process them. In this mode, the input buffer will contain a maximum of one message. (A message may be one command or one record, depending on the setting of the record mode.) When turned off, messages are read from the IEEE-488 interface to the input buffer of the Generator at the fastest rate. In this mode, the input buffer may contain up to 80 characters.

The valid mode selects when messages are processed by the Generator microprocessor. When turned on, processing of a new message is begun only after the RF output has settled and become valid. When turned off, a new message is processed immediately after the completion of the previous message.

The interface modes can also be programmed using the command, "@n" (where n is an integer). The interface modes are set to the value of n where n is the sum of the codes for the desired modes. The integer codes for the interface modes that can be programmed using the "@n" commands are as follows:

- Terminator Mode = 1
- Record Mode = 2
- Valid Mode = 4
- Unbuffered Mode = 8
- Error Mode = 16

For example, to select the record mode and valid mode, the command is "@6".

Interface Mode Example

In this example, the RF output of the Generator is connected to a circuit that is being measured by a voltmeter. The output of the Generator must be settled before the voltmeter is given its command to make a measurement.

Table 2-13. Interface Mode Commands

COMMAND	DESCRIPTION	COMMAND STATUS
"EM"	Error Mode	1 = on, 0 = off
"RM"	Record Mode	1 = on, 0 = off
"TM"	Select Terminator	1 = CR, 0 = LF
"UM"	Unbuffered Mode	1 = on, 0 = off
"VM"	Valid Mode	1 = on, 0 = off

A Fluke 1722A program might look something like:

```
PRINT @1, "CL, TM1, RM1, VM1, UM1" ! initialize the 6060A/AN, select modes
PRINT @1, "FR100MZ, AP-25DB"      ! program the 6060A/AN
PRINT @2, "?"                      ! trigger the voltmeter
INPUT @2, R$                       ! get the reading
```

The entire record is transferred into the Generator before processing begins. In this example, processing begins when the record terminator CR is received. The following character (LF in this case) will not be received into the Generator until the entire record is processed and the output has settled. No WAIT statement is needed between setting up the Generator and taking the measurement because the Generator will not handshake the LF character until its output has settled.

NOTE

A record is a string of characters separated by <EOR>. A message is the smallest group of characters that the Generator can process when programmed from the IEEE-488 interface.

NOTE

The output valid state of the Generator occurs 45 ms after any hardware has been changed.

2-59. INTERROGATE COMMANDS

Interrogate commands allow the status of the Generator to be given over the IEEE-488 interface. These commands consist of headers only. The interrogate commands available on the IEEE-488 interface are:

- "ID" Give Instrument ID
- "II" Interface Mode Status
- "IO" Option Loading
- "IR" IEEE-488 Rejected Entry Status
- "IT" Self-Test Results
- "IU" UNCAL (uncalibrated) Status
- "IV" Software Revision Level

When the "ID" command is sent, the Generator responds with its instrument model number (and end of record character) as in "6060A/AN" <EOR> .

The "II" command interrogates the current selection of interface modes. A 5-digit integer followed by the <EOR> character is the sum of the modes that are selected as follows:

- Terminator Mode = 1
- Record Mode = 2
- Valid Mode = 4
- Unbuffered Mode = 8
- Error Mode = 16

The "IO" command interrogates the Generator for its option complement. The returned record contains 3 integers, separated by commas, that indicates configuration of options. The 6060A/AN has no options and the string returned will always be "5,0,1".

The “IR” command interrogates the Generator for rejected entry error status. (See Table 2-6 for a list of rejected entry codes.) The returned record is the sum of errors that have been detected while processing IEEE-488 commands. The status is cleared when interrogated with the “IR” command. The status can also be explicitly cleared with the “CE” command, the “CL” command, and the clear interface messages DCL and SDC.

The “IT” command interrogates the Generator for the self-test results. Table 2-14 lists the self-test error codes. The self tests are performed on the Generator power-up and can also be initiated with special function 02.

The self-test results are reported in four fields, which are explained in the table. Any non-zero code indicates that some tests failed. Further details of the self-test results are listed in the Service Section. Table 2-14. shows the self-test error codes.

The “IU” command interrogates the Generator for the UNCAL entry status. (See Table 2-5 for a list of the UNCAL Error Codes.)

The “IV” command interrogates the Generator for its current software revision level. The returned record is similar to the following:

“V1.0” (EOR)

This means that the software revision level is Version 1.0.

2-60. MONITOR COMMANDS

The Generator monitor commands are intended for troubleshooting and maintenance procedures. They allow the instrument hardware to be programmed to states not normally possible with the regular programming commands.

CAUTION

The output of the Generator is not guaranteed if the Generator hardware has been changed with these monitor commands.

There are 3 types of monitor commands: Input/Output, Read/Write, and Hardware Control. Table 2-15 lists the Input/Output types of monitor commands. Table 2-16 lists the Read/Write types of monitor commands. Table 2-17 lists the Hardware Control types of monitor commands.

Table 2-14. Self-Test Error Codes

MOD	FREQ	AMPL
aaa	-bbb ccc	ddd
aaa = Modulation (AM and FM) test results - = If displayed, indicates the self test did not complete bbb = Frequency test results ccc = Digital test results ddd = Amplitude test results		

Table 2-15. Input/Output Monitor Commands

COMMAND NAME	COMMAND	VALUE	DESIGNATOR NAME	LOCATION
Read Input Bit	"IB"		"DR" drl	A4A2, U5-12
			"DV" datavalh	A4A2, U5-4
			"EX" exrefl	A2A7, U11-13
			"HS" hsoptl	A2A7, U11-14
			"IE" ieinl	A2A7, U11-7
			"LF" lrfm	A2A7, U40-13
			"MH" mlevhi	A2A7, U40-8
			"ML" mlevlo	A2A7, U40-3
			"NV" nvinl	A2A7, U11-8
			"RO" roptl	A2A7, U40-17
			"RP" rppl	A2A7, U11-3
			"RT" rptrpl	A2A7, U11-4
			"SR" shrefl	A2A7, U40-18
			"TQ" trseql	A2A7, U40-4
			"UK" unlok	A2A7, U11-17
			"UV" unlvl	A2A7, U11-18
			"XA" extra-a	A2A7, U40-14
			"XB" extra-b	A2A7, U40-7
Set Output Bit	"OB"	0 or 1	"CL" clr	A2A7, U17-16
			"CV" converth	A4A2, U4-13
			"EA" extam	A2A4, U308-19
			"EF" extfm	A2A4, U308-16
			"FE" fmen	A2A1, U19-19
			"FP" front-panel	A2A7, U17-9
			"HO" haocth	A2A4, U305-5
			"HT" het	A2A4, U305-9
			"IA" intam	A2A4, U308-15
			"IF" intfm	A2A4, U308-12
			"LP" mid	A2A4, U305-6
			"MA" rmux0	A2A1, U32-5
			"MB" rmux1	A2A1, U32-2
			"MF" mf400L	A2A4, U308-9
			"MG" module-gate	A2A7, U17-6
			"MS" trmodl	A2A1, U32-15
			"MT" meteronh	A4A2, U3-15
			"NE" nven	A2A7, U17-5
			"PK" pospeakl	A4A2, U3-9
			"PU" pulse	A2A4, U308-6
			"RG" rng50kh	A4A2, U3-6
			"RI" rinl	A2A1, U32-9
			"RR" rprst	A2A7, U17-2
			"SE" shen	A2A1, U32-12
			"SH" shet	A2A1, U32-16
			"TO" tbout	A2A4, U305-2
			"TR" trigh	A4A2, U3-3
			"TS" tbsyn	A2A1, U32-19
"XO" xoent	A2A1, U32-6			
"YA" extra-a	A2A7, U17-19			
"YB" extra-b	A2A7, U17-15			
"YC" extra-c	A2A7, U17-12			
Set Output DAC	"OD" (integer value)	(DAC Location)	0-255 "AM" AM dac	n.a.
			0-127 "AT" attenuator	A2A7, U27-5, 6, 9, 12, 15, 16, 19
			0-1023 "FM" FM dac	A2A4, U403-6 through 13
			0-7 "FR" FM range	A2A1, U19-12, 15, 16
			0-1023 "KN" kn dac	A2A1, U27-4 through 13
			0-1023 "KV" kv dac	A2A1, U29-4 through 13
			0-4095 "LE" level dac	A2A4, U303-4 through 15
			0-255 "TC" temp.comp.dac	n.a.

Table 2-16. Read/Write Monitor Commands

COMMAND NAME	COMMAND SYNTAX	NOTES
Read byte	"RB" memory location	1
Read word	"RW" memory location	1
Define write address	"DW" memory location	2
Write byte	"WB" value	2
Write word	"WW" value	2

Notes

1. The Generator responds to these commands with the value of the byte or word in the memory location addressed. The memory location must be an unsigned integer. The value returned is followed by an <EOR>. If the memory location is specified in hexadecimal, then the value is returned in hexadecimal preceded by an "X".
2. The Define Write Address command specifies the write address used with the Write Byte and Write Word commands. When the Write Byte and Write Word commands are used, the specified data will be written to that write address.

Table 2-17. Hardware Control Monitor Commands

COMMAND NAME	COMMAND SYNTAX	NOTES
Read attenuation	"XA"	1
Set attenuation	"XB" integer	1
Set synthesizer frequency	"XD" floating point decimal "MZ"	2
Read Deviation Meter A/D	"XM"	3
RF on/off	"XR" "0" or "1"	4

Notes

1. The current settings of the Attenuator can be read or set. The attenuation is a number from 0 to 23 where the number specifies the multiple of 6-dB attenuation. Zero indicates no attenuation, and 23 is the maximum attenuation. Only the attenuators are changed with the "XB" command. The value of the attenuation will be output on the "XA" command as an unsigned integer followed by <EOR>.
2. The "XD" command can be used to program the Generator to the specified frequency. Only the synthesizer circuits on the Synthesizer PCA are programmed. No offset is added, no filters are programmed, no VCO compensation is calculated, and no level correction is calculated.
3. The "XM" command reads the A/D chip on the A/D PCA (A4A2, U1) directly. The integer returned is the A/D result with 50-Hz or 500-Hz resolution in the 50.0-kHz and 500-kHz ranges, respectively. One A/D result is returned (i.e., no averaging is performed).
4. "XR0" programs all attenuation, and "XR1" restores the attenuator to its previous state.

2-61. SRQ COMMANDS

The Generator asserts the SRQ bus management line on the IEEE-488 interface bus whenever the Generator requires service. The Controller can then perform a serial poll to

determine the need for service. The set mask command is used to designate those needs that require service. The SRQ commands are as follows:

- “SM” Set SRQ Mask
- “IM” Interrogate SRQ Mask
- “XF” Local Operation Alert Mode

The SRQ mask is set to the sum of the reason values listed in Table 2-18. These reason values correspond to the allowable reasons that will be requiring service. The SRQ Mask is set by the following command sequence:

- “SM” Sum of Reasons

The Generator asserts SRQ when one of the allowed reasons becomes true. The serial poll response is the sum of those values for reasons that are currently true, independent of the setting of the SRQ mask. For example, if the rejected entry SRQ is enabled with “SM2” and a rejected entry occurs, the serial poll response will indicate that the Generator generated the SRQ (value of 64) and that a rejected entry occurred (value of 2). In addition, other values may be set. The default SRQ mask is 192.

The “IM” command interrogates the current SRQ mask, and an integer is returned.

The “XF” command enables a mode that causes an SRQ to be generated any time the Generator processes an entry. In this mode, a front panel SRQ is generated (i.e., the serial poll response indicates that a front panel SRQ is the cause of the SRQ). This mode is enabled and disabled with its own command, not through the Set SRQ Mask commands (as are all other SRQs). The Alert Mode is enabled/disabled as follows:

- “XF0” = Alert Mode off, “XF1” = Alert Mode on.

2-62. TRIGGER COMMANDS

The Generator has the ability to preprogram a command string of arbitrary Generator programming commands. This command string is executed whenever the trigger command “TR” or the IEEE-488 group execute trigger interface message (GET) is received. This method of programming the Generator can be used when a long string of commands is to be sent to the Generator over and over. The programming time is shortened by the time required to transmit the string of characters from the controller to the Generator.

The trigger commands are as follows:

- “CT” Configure Trigger
- “TR” Execute Trigger Buffer

The configure trigger command is followed by a string of any Generator programming commands up to 71 characters in length. The validity of the programming commands is not checked until the trigger buffer is executed. The power-on value of the trigger string is null (nothing).

The trigger command causes execution of the trigger buffer, which has been preprogrammed with the configure trigger command “CT”. The trigger buffer can also be executed by sending the IEEE-488 group execute trigger interface message (GET).

Table 2-18. SRQ Mask and Status Values

VALUE	REASON	TRUE	FALSE
1	Ready	Input buffer is empty and no commands are being processed.	Input buffer is not empty or commands are being processed.
2	Rejected Entry	IEEE-488 rejected entry; error code is not zero.	IEEE-488 rejected entry error; code is zero.
4	Uncalibrated	RF output is not calibrated. (Front panel 'UNCAL' indicator is lit.)	RF output is calibrated. (Front panel 'UNCAL' indicator is not lit.)
8	Power on	Instrument has powered up.	Special function 08.
16	Output valid	RF output is settled.	RF output is not settled.
32	Not Used		
64	RQS	SRQ mask ANDed with currently set values is not zero.	Reason for SRQ goes away or serial poll is performed.
128	Front panel	Special function 07.	Special function 08.

2-63. Command Processing

The following paragraphs describe how IEEE-488 commands are processed by the Generator. Command processing is a term for how commands are executed and how errors are handled.

2-64. COMMAND EXECUTION

The execution of the IEEE-488 commands depends on the selection of interface modes with one exception: if an IEEE-488 input is buffered and the buffer becomes full, command execution starts and no further input is accepted until there is room in the input buffer. For more details, refer to the INTERFACE MODE COMMANDS paragraphs.

2-65. ERROR HANDLING

The Generator detects two types of errors while processing IEEE-488 commands: syntax errors and processing errors. All errors are accumulated until the error status is interrogated or is explicitly cleared. The IEEE-488 rejected entry status is interrogated with the "IR" command. The error status is cleared with one of the following commands:

- "CE" Clear Error Command
- "CL" Clear Command
- DCL or SDC Clear Interface Messages

The error status is also cleared on power-up.

The SRQ mask can be set to assert SRQ when an error is detected. The SRQ is unasserted when the error status is cleared.

Syntax errors are commands that do not have the correct syntax for the specified header. For example, "FES" is a syntax error because the external FM command requires a Boolean numeric field. Unrecognized headers are also syntax errors. An IEEE-488 syntax error causes all commands from the point of the error up to the next string terminator or record terminator to be ignored.

Processing errors are commands that are syntactically valid, but the requested value is outside the range of programmable values. For example, "FR99GZ" is syntactically correct, but the Generator cannot be programmed to a frequency of 99 gigahertz. Command processing continues with the next command.

2-66. Timing Data

The programming time can be broken down into four groups: transfer of commands to Generator, command parsing time, software programming time, and instrument settling time.

The total programming time depends on the selection of the interface modes. In some modes, programming steps are performed in parallel and can increase throughput. This section gives some typical timing data for the above four programming steps and describes how the interface modes affect their relative timing.

2-67. TRANSFER OF COMMANDS TO GENERATOR

The maximum rate of transfer is 0.4 to 0.5 ms per character. With most IEEE-488 controllers, all characters sent with a single output or print statement are transferred together at the maximum rate. The total time to transfer commands to the Generator is obtained by multiplying the number of characters by the rate of transfer.

2-68. COMMAND-PARSING TIME

Command-parsing time is the sum of the time required to process the header, the numeric, and the suffix. Some commands do not have numerics or suffixes.

Table 2-19 gives the typical time it takes to process the different components of a command.

2-69. SOFTWARE PROGRAMMING TIME

The minimum time required to process a command is 20 ms. Most of the commands that do not program the hardware (such as storing step values) are programmed in 20 ms. Table 2-20 gives the typical time value for programming the different functions in the Generator.

2-70. INSTRUMENT-SETTLING TIME

Commands that do not change the state of the hardware (such as programming step values) have no settling time after the software-processing time.

For all other Generator parameters, except frequency and recall, the instrument has settled by the time the software-programming time is up; so no additional instrument-settling time is required.

Worst case frequency changes (including recalls) typically settle within 35 ms after the software-programming time. If level correction is disabled, this settling time is increased to 45 ms. Small frequency changes (not crossing a band) typically settle by the time the software-programming time is up, so no additional instrument-settling time is required.

Table 2-19. Command-Parsing Time

COMMAND COMPONENT	TIME
Header	2 ms
Boolean Numeric	1 ms
Unsigned Integer Numeric	2 ms + 1 ms per character
Floating-Point Numeric	2 ms + 1 ms per character
Trigger-String Numeric	10 ms + 0.5 ms per character
Suffix	1 to 1.5 ms
Learn-Interface Suffix	35 ms

Table 2-20. Typical Programming Time of the Generator Functions

FUNCTION	TIME (in ms)	NOTES
Frequency	55	1, 2, 3, 4
Amplitude in Volts	50	1, 2, 4, 5
Amplitude in dBm	90	1, 2, 4, 5
AM Depth	45	2, 4
FM Deviation	30	4
Modulation Frequency	25	
Enable/Disable AM	55	2,
Enable/Disable FM	25	
Recall 98	185	6, 5
RF Output On	45	2
RF Output Off	30	

Notes

1. May take up to 5 ms longer if the relative mode is enabled.
2. Can save 10 ms if all level correction is disabled with special function 81.
3. Add 20 ms when frequency changes from greater than or equal to 245 MHz to less than 245 MHz. Subtract 20 ms from frequency hardware settling time in this case.
4. Edits and steps may take up to 5 ms longer than the programming function directly.
5. Add 5 ms when the Attenuator settings change.
6. Recalls vary considerably depending on the stored data. Maximum is approximately 250 ms.

2-71. TIMING OPTIMIZATION

Timing depends upon the interface modes selected. Read the paragraphs on INTERFACE MODE COMMANDS for a complete description of the interface modes.

The transfer of commands from the IEEE-488 controller to the Generator can never be processed in parallel with anything else. The transfer of commands usually happens simultaneously, regardless of which interface mode is selected.

The parsing of the command and programming the new instrument state are performed one message unit at a time. The record mode selects a command or a record as the

message unit. The record mode off ("RM0") is slower since there is extra processing between message units, and the message unit is smaller.

If the valid mode is enabled, the processing of message units is delayed until the Generator has settled from the previous message. If the output of the Generator does not need to be settled between programming strings, the valid mode should be turned off to speed up processing. If the output does not need to be settled between commands, but needs to be settled between records, enable the valid mode and the record mode. The instrument processes commands within the record as fast as possible and waits for the output to settle only between records.

2-72. Power-on Conditions

The power-on conditions of the Generator are listed in Table 2-21. The remote clear commands can be used to reset all parameters except the last memory location and the remote/local state.

Table 2-21. IEEE-488 Power-On State

INSTRUMENT PARAMETER	STATE	NOTES
Memory location parameters	98	1
RF on/off	on	
Last memory location	0	2
Remote/local state	local	
IEEE output buffer	cleared	
IEEE input buffer	cleared	
Valid mode	off	
Record terminator	LF	
Unbuffered mode	off	
Record mode	off	
SRQ mask	192	
Trigger configuration	cleared	
SRQ interface signal	unasserted	
Deviation meter mode	off	
Deviation meter peak	positive	
Deviation meter range	500 kHz	
<p>Notes</p> <ol style="list-style-type: none"> 1. The contents of memory location 98 (Instrument Preset State) is listed in Table 2-3. 2. The last memory location is used for sequence operations. 		

Section 3

Theory of Operation

3-1. INTRODUCTION

This section of the manual describes the theory of operation for the Generator. There are four major headings:

- General Description
- Functional Description
- Software Operation
- Detailed Circuit Descriptions

The General Description briefly explains the functions and components of the four major modules of the Generator. The Functional Description covers the main instrument parameters, amplitude, frequency, and modulation. The Software Operation section describes the software and how it affects the hardware. The Circuit Description is a comprehensive explanation of the operation of each circuit assembly.

3-2. GENERAL DESCRIPTION

The Generator has four major sections. The front section includes the keyboard and display for local control. The module section includes the frequency, level, modulation, and control circuits. The rear section includes the power supply, cooling fan, IEEE-488 Interface, and assorted external connectors. The deviation meter section includes the discriminator and the A/D circuits.

3-3. Front Section

The front section of the Generator provides the operator interface. It includes the primary controls, connectors, and indicators of the Generator. All front panel keys and displays (except the power switch that controls the power supply directly) are monitored and handled by the Controller in the module section.

3-4. Module Section

The module section is a multi-compartmented, shielded enclosure that includes the circuits that generate the instrument stimulus functions of frequency, modulation, and amplitude. The Controller (which is not shielded) is also located here. The Controller controls the operation of the Generator.

3-5. Rear Section

The rear section includes the power supply, the cooling fan, the IEEE-488 Interface, and various external connectors.

The power supply is a linear design providing two +15V, -15V, +5V, +37V, +18V, and 6V ac to the Generator. All the power supplies are series-pass regulated except the 6V ac filament supply and the +18V supply, which provides power to the Attenuator/Reverse Power Protection (RPP) relays. A fuse/filter/line-voltage selector allows the Generator to operate from different supply voltages.

The dc fan is powered from the unregulated +5 volt supply. The fan operates only when line power is available and the front panel POWER switch is ON.

3-6. Deviation Meter Section

The deviation meter section consists of two circuit boards. The discriminator is mounted in an RF tight module. The A/D board plugs into the discriminator and interfaces to the Controller. The input to the deviation meter is a front panel BNC connector.

3-7. FUNCTIONAL DESCRIPTION

The following paragraphs describe the key output parameters of the Generator: level, amplitude modulation, frequency, and frequency modulation. The deviation meter is briefly described.

3-8. Level

Level control is provided by two separate circuits: a step attenuator and a vernier level DAC. The 6.02 dB per step Attenuator/RPP (A2A5) provides coarse control. Fine level control is provided by a vernier level DAC that varies the automatic level control voltage (ALC). The microprocessor automatically controls the step attenuator and the vernier level DAC. The microprocessor also applies level correction to compensate for the Generator frequency response.

Each Generator has level correction data for the Output and Attenuator assemblies. The data is stored in the Output and Attenuator calibration EPROMs, which are located on the Controller assembly. The correction data is based on measurements of each assembly during calibration of the Generator at the factory. The Attenuator data is the same for all Generators.

This microprocessor level correction data is applied only to the vernier level DAC; it does not affect the coarse level control provided by the Attenuator. In other words, all Generators have the same attenuator pads inserted at a selected level, even though the correction data is different for each Generator.

To improve level accuracy in relation to temperature, the Generator uses a software temperature compensation technique. This technique uses data that is the same for all Generators.

3-9. Amplitude Modulation

The output of the level DAC is the ALC loop control voltage. The Generator output signal is amplitude modulated by varying this control voltage with the modulating signal. A 1V peak modulating signal from the internal modulation oscillator or from the external MOD INPUT connector is applied to the AM DAC, a multiplying D-to-A converter. The multiplying factor of this DAC, corresponding to the programmed percentage of modulation, is factored by the Controller.

The modulation signal from the AM DAC is summed with a fixed dc reference voltage. The composite signal (dc plus modulation) is applied to the LEVEL DAC, a level control-multiplying DAC. The multiplying factor for this DAC is also handled by the Controller and corresponds to the programmed signal level. The multiplying factor also includes the level correction information stored in the calibration EPROMs.

The operation of the ALC loop causes the amplitude of the RF signal to conform to this varying control voltage, thus amplitude modulating the Generator output.

3-10. Frequency

The 0.01-MHz to 520-MHz frequency coverage is divided into the following two bands:

Low band:	0.01 MHz to 245 MHz
Mid band:	245 MHz to 520 MHz

The mid band is derived directly from a voltage-controlled oscillator (VCO) followed by a binary divider that is part of the main phase-locked loop (PLL). The low band is derived by heterodyning the direct VCO frequency with a fixed 800-MHz signal.

This PLL synthesizes the 245-MHz to 525-MHz band using a modified N-divider loop with a single-sideband mixer (SSB) in the feedback path. The reference frequency for the loop is 0.2 MHz, which would normally provide 0.2-MHz steps in a conventional N-divider loop. However, this Generator provides 0.01-MHz steps by using a modified N-divider circuit with pulse deletion controlled by a rate multiplier.

Additional resolution is gained by introducing a signal from the sub-synthesizer circuit into the main PLL through the SSB mixer in the feedback path. This signal provides internal frequency steps of 5 Hz. The sub-synthesizer consists of a 14-bit rate multiplier followed by a divide-by-2000.

Since the main PLL bandwidth varies with the programmed frequency (due to N multiplication changing and variations in the VCO tuning coefficient), the Controller uses compensation to program the phase detector gain via the KN DAC to maintain constant loop bandwidth. By keeping the loop bandwidth constant, loop stability and modulation transfer are controlled, thus ensuring accurate, wideband FM.

3-11. Frequency Modulation

Frequency modulation is achieved by applying the modulation signal simultaneously to the PLL VCO and the Phase Detector. Both are necessary because modulating either the VCO or the Phase Detector alone results in FM with a high-pass filter characteristic, or phase modulation with a low-pass filter characteristic. The filter characteristic cutoff frequencies are approximately equal to the PLL bandwidth.

The modulating signal applied to the VCO and the Phase Detector is adjusted in amplitude by the KV DAC to compensate for variations in the VCO tuning coefficient. This compensation is done automatically by the Controller, using factory calibration data measured on the VCO in each Generator. This compensation data is stored in the VCO Calibration EPROM.

By integrating the modulation signal applied to the Phase Detector and simultaneously applying the modulation signal to the VCO, the two effects are complementary and result in a flat FM response.

3-12. Deviation Meter

The Deviation Meter is a heterodyne receiver with an IF frequency of 1.5 MHz. The Generator output is transferred from the attenuator RF output to the Deviation meter local oscillator input or Generator RF OUTPUT by a relay. The charge-count discriminator is preceded by a high-gain limiter amplifier. The recovered audio is filtered and peak detected. The DC voltage output of the peak detector is converted to digital information with an analog-to-digital converter (A/D). The output of the A/D interfaces to the Controller.

3-13. SOFTWARE OPERATION

The Generator software is executed on a Texas Instruments TMS 9995 microprocessor in the A2A7 Controller assembly. The instrument program is stored in 48K-bytes of ROM, two scratch pad RAMs, 2K-bytes off-chip RAM and 250 bytes on-chip RAM. Three 2K-byte EPROMs contain the individual Generator calibration data. The software provides the following general functions:

- Interfaces with the front panel keys and the IEEE-488 Interface to provide access to the Generator functions.
- Configures the Generator functional blocks to produce the required output and then applies linearization and compensation data to optimize the instrument performance and resolution.
- Implements a set of self test and diagnostic functions.

3-14. User Interface

The Generator software is implemented with a simple operating system that allows several tasks to operate in a round-robin fashion on an equal priority basis. Input and output to the front panel and to the IEEE-488 Interface, however, execute at a higher priority and are handled as interrupt routines.

At power-on, the software performs an instrument self test and initializes both the RAM and the Generator hardware. Three tasks are continuously in operation:

Service task
Key task
IEEE-488 task

The service task checks the status signals. The key task and IEEE-488 task process user input. A fourth task is activated only when needed to process certain UNCAL (uncalibrated) or REJ ENTRY (rejected entry) conditions that cause the instrument STATUS display to flash.

3-15. Amplitude Control

Amplitude is programmed using a 23-step (6.02 dB per step) attenuator assembly and a 12-bit vernier level DAC. The level DAC settings depend on a combination of the programmed output level and amplitude correction data.

The amplitude correction data compensates for level inaccuracies and is a function of the Generator frequency. Correction factors are stored in the Output and the Attenuator Calibration EPROMs. Each Output and Attenuator assembly comes with a matched calibration EPROM. The assemblies may be replaced under the Module Exchange Program, with only minor adjustments needed after the replacements are installed.

3-16. Attenuators

One 6-dB, one 12-dB, and five 24-dB sections of the Attenuator are programmed in combination to provide course level control. The indicated voltages at which the Attenuator changes ranges are 2^{-m} volts, where

$m = 1, 2, 3, \dots, 23$ for non-AM, or

$m = 2, 3, 4, \dots, 24$ for AM operation

Table 4D-14 lists the Attenuator sections programmed for various displayed levels.

3-17. Level DAC

The level DAC setting (LEV 0 through 9) is calculated from the Generator output level. If level correction is enabled, the level DAC setting is further modified by the data stored in the Output and Attenuator calibration EPROMs.

To minimize level transients that could damage external circuitry, the following sequence is used in programming the Attenuators and the level DAC when the Attenuator setting is changed:

1. The LEVEL DAC is programmed to zero.
2. The new Attenuators are programmed in addition to the old Attenuators.
3. After a 5-ms wait to allow the Attenuators to settle, the new Attenuator and LEVEL DAC settings are programmed.

3-18. Temperature Compensation

The temperature compensation DAC (TC DAC) data is stored in the Generator software as a function of the output frequency (F_o). This data is the same for each Generator.

3-19. Reverse Power Protector

The Reverse Power Protection (RPP), part of A2A5, protects the Generator from damaging voltages applied to the RF OUTPUT connector. The status line RPTRPL indicates whether the RPP circuitry has tripped. If the RPP trips, the RF output is programmed off, and the RF OFF indicator flashes. The RPP circuitry is reset when the operator turns the RF OUTPUT on. This causes the Controller to reset the RPP by toggling RPRSTL, and programming the RF on.

3-20. Frequency Reference Control

Programming of the frequency reference control bits depends on the setting of the INT/EXT reference switch.

3-21. Frequency Control

The output frequency (F_o) is programmable with 10-Hz resolution. The minimum calibrated output frequency is 0.01 MHz, and the maximum calibrated output frequency is 520 MHz. The filter and band control bits are programmed in two bands and are determined by the output frequency (F_o). For each band, a synthesizer frequency is determined.

The programming data of the KV and KN DACs is calculated from the synthesizer frequency and the instrument-specific VCO Calibration EPROM data. The KV DAC settings on the low band is one half the settings on the mid band; this compensates for the effective doubling of the FM deviation that occurs on low band. The low band is derived by heterodyning the direct signal from the VCO (800.01 to 1044.99999) with a fixed 800 MHz signal.

3-22. Modulation On/Off

The four modulation modes are:

- Internal AM
- External AM
- Internal FM
- External FM

The modulation modes can be programmed separately or in any combination. The AM depth and FM deviation DACs are always programmed whether or not modulation is enabled. When enabling or disabling modulation, only the modulation control bits are programmed. Table 4D-16, Modulation ON/OFF Control, lists the control states for each modulation choice.

3-23. Modulation Frequency

The two internal modulation frequencies of 400 Hz and 1000 Hz are programmed with a single control bit, MF400L. Table 4D-17, Modulation Frequency Control, lists the MF400L control states.

3-24. Amplitude Modulation

The Generator allows amplitude modulation depth programming from 0 to 99% with 1% resolution. When the combination of signal amplitude and programmed AM depth exceeds +13 dBm peak, the UNCAL indicator lights to warn you that the output level is no longer guaranteed. Amplitude modulation depth is programmed using the 8-bit AM DAC, with a setting of 200 on the AM DAC, corresponding to 100% AM modulation of the output frequency.

3-25. Frequency Modulation

Frequency modulation (FM) is programmable with three digits of resolution in the two and one-half decade ranges. Table 4D-12, FM Ranges, lists the three ranges.

3-26. FM Deviation

The FM DAC is a 10-bit DAC programmed to the FM deviation in Hz divided by the resolution. Table 4D-13 lists the settings of the FM DAC.

3-27. Deviation Meter

The deviation meter hardware is configured by programming three control signals: peak, range, and meter mode. The FM deviation readings consist of 10 bits of A/D output and two status signals: ready and valid. Table 4D-18, Deviation Meter Control, lists the values of the programming and status bits.

The deviation meter readings are initiated by sending a trigger pulse to the discriminator circuit. This is done by setting the TRIGH signal to a TTL High for approximately 10 ms. Next, the software waits 80 ms for the sample and hold circuit to acquire a sample. Then the A/D chip is triggered and the 10-bit result is read when the data ready signal becomes a TTL Low. The 10-bit A/D result represents the deviation with 100-Hz or 1-kHz resolution in the 50-kHz or 500-kHz range respectively. The 32 A/D results are averaged for each reading displayed on the front panel.

3-28. Self Test

At power-on, the Generator automatically self tests its digital and analog circuits. If the Generator fails any self test, the test results are automatically displayed as error codes. Several special functions are available for additional tests. (See the Service Special Functions paragraph in Section 4.) Also, the Generator microprocessor continuously monitors two status signals, UNLVL (unleveled) and UNLCK (unlocked).

The self tests can also be initiated by using the [SPCL][0][2] keys. The results of the self test can be displayed in the four display fields with [SPCL][1][1] keys and can also be transmitted using the IEEE-488 Interface.

Self tests 1 through 5 are digital checks that test the general functionality of the Controller assembly. Self tests 6 through 9 use the two status signals UNLVL and UNLCK to test the general functionality of the RF circuitry.

During the self-test sequence all attenuators are programmed ON (maximum attenuation) to prevent unwanted signals at the output. In addition, the Generator is programmed to the internal frequency reference because the self tests fail if no reference is supplied.

The self-test error codes and descriptions are listed in Section 4D. The different Generator self tests are briefly described below:

- Test 1. The Generator RAM is verified by writing data to each memory location and checking that the same data can be read back. Both the off-chip RAM and the on-chip RAM are tested in this way.
- Test 2. The data in each word of the two instrument software EPROMs is successively summed and rotated by two. The result of this procedure is compared with a checksum for each EPROM.
- Test 3. The data in each of the three calibration EPROMs (VCO, Output, and Attenuator) is summed and compared with a checksum.
- Test 4. The IEEE-488 Interface is verified by the microprocessor writing data to the IEEE-488 chip and then reading it back to see if the response is the one expected. The operator is given a report only if the test fails.
- Test 5. The low-pass filters on the Output assembly are tested by setting the frequency at the top of each of the two half-octave non-HET bands and verifying that the output is leveled. Then, the frequency is set above the cutoff frequency, and the output is checked to see if the output is unleveled.
- Test 6. The synthesizer operation is verified by programming the Generator to a normal operating frequency and checking to see that the instrument is locked. The Generator is then programmed to a synthesizer frequency below 225 MHz and then to a frequency above 550 MHz, and is checked to see that the instrument becomes unlocked. Finally, all frequency reference circuitry is turned off and checked to see that the Generator becomes unlocked.
- Test 7. The Generator PLL operation is verified by forcing a large change in frequency. When this is done, the Generator should become unlocked and then lock again.
- Test 8. Frequency modulation is verified by programming internal FM on and programming the range and DAC to full scale. The unlocked indicator should be in the locked state.
- Test 9. Amplitude modulation is verified by overmodulating the carrier and then checking the unlevel indicator. This is done by programming a high output level and programming INT AM on with strong amplitude modulation.

3-29. Service Special Functions

There are two special function self tests for the front panel indicators and keys. These special function self tests are described in the following:

1. The front panel displays are checked at any time by pressing the [SPCL][0][3] keys. When this is done, the microprocessor lights all display segments. This test is terminated by pressing any key on the instrument.
2. Check the normally open front panel keys by pressing the [SPCL][0][4] keys. Then, each key pressed has its row and column address displayed in the center of the FREQUENCY display field. The special function is exited by pressing the [CLR|LCL] key.

3-30. Status Signals

The status of the rear panel REF EXT/INT reference switch is continuously monitored with the EXREFL bit. The state of this bit is used by the Controller to display the EXTREF indicator on the front panel and to program the reference source.

The RF output of the Generator is considered calibrated whenever the UNCAL indicator is off. The UNCAL indicator is lit, but not flashing, whenever the calibrated limit of the Generator is exceeded. However, the RF output is still considered usable.

The UNCAL indicator flashes when the output of the instrument is considered unusable. This is the result of a severe overrange condition or when one of the following analog status signals becomes active:

- RPTRPL = 0 indicates that the Attenuator Reverse Power Protection (RPP) circuitry has tripped. If this occurs, the RF output is programmed off to provide additional protection to the instrument. The RF OFF and UNCAL indicators flash to indicate that RPP has tripped.
- UNLOKL = 0 indicates one of several conditions. The Synthesizer circuits could be out-of-lock. If FM is on, it could also indicate FM over-modulation. The UNCAL indicator flashes for any of these circumstances.
- UNLVLL = 0 indicates that the output is unleveled. This could also be the result of amplitude over-modulation. With this condition, the UNCAL indicator flashes.

3-31. DETAILED CIRCUIT DESCRIPTIONS

This section contains the detailed circuit descriptions for the following assemblies:

A1 Front Section

A1A1 Display Assembly

A1A2 Switch Assembly

A2 Module Section

A2A1 Synthesizer Assembly

A2A2 VCO Assembly

A2A4 Output Assembly

A2A5 Attenuator/RPP Assembly

A2A7 Controller Assembly

A3 Rear Section

A3A1 Power Supply Assembly
A3A3A1 IEEE-488 Assembly

A4 Deviation Meter Section

A4A1 Discriminator Assembly
A4A2 A/D Assembly

3-32. FRONT SECTION, A1

The Generator front section, A1, consists of the Display PCA A1A1, the Switch PCA A1A2, and the elastomeric switches mounted in a sheet metal housing. The front section also includes the display lens, the POWER ON/OFF switch, the MOD INPUT connector, and the DEVIATION METER INPUT connector.

3-33. Display PCA, A1A1

The Display PCA A1A1 provides a readout of the programmed modulation, frequency, amplitude parameters, and status information. This displayed information and the bright digit are controlled by the Controller, A2A7, under the direction of the instrument software. The display is comprised of two vacuum fluorescent displays and their associated control circuitry. The two displays are refreshed as four groups of eight display fields (usually a digit) each. The four groups share the digit (grid) strobes but have individual segment (anode) strobes.

3-34. DATA COMMUNICATIONS

Display data is sent through a byte-wide bidirectional data bus from the Controller A2A7 and is latched by U1 through U5 on the display board. Latch-select signals DIGL, SEG1L, SEG2L, SEG3L, and SEG9L determine which latch receives the data. Level shifting buffer drivers U6 through U10 interface the TTL latches directly to the +37V anodes of the vacuum fluorescent displays.

3-35. DISPLAY FILAMENT VOLTAGE

The 6.0V ac filament voltage for the display is derived from a center-tapped winding on the power supply transformer, T1. The ac filament voltage is biased at +6.2V above ground by circuitry on the power supply board A3A1, to provide a cutoff potential for the displays.

3-36. BRIGHT-DIGIT EFFECT

The bright-digit effect is achieved by providing three extra refresh cycles (strobes) to the specified digit. Grid current-limiting resistor R3 provides uniform digit brightness by controlling electron depletion from the display cathode filaments.

3-37. SWITCHBOARD INTERFACE

The digit strobe data latched by U1 is buffered by open collector inverters U13 and U15, and strobes the front panel switch matrix. The switch columns are strobed in unison with the eight display fields. The switch matrix status is read by the tri-state buffer U14.

3-38. DISPLAY BLANKING

Monostable U11 and NOR gate U12 clear the display if new field or segment strobes are not received. This protects the display if the microprocessor stops refreshing. The display can be blanked manually by pressing [SPCL][1][3], which sets the signal CLRL and the output of U11 low, thus clearing latches U2 through U5. To restore the display, press [SPCL][1][2].

3-39. MODULATION-LEVEL INDICATOR

The external modulation-level indicator warns the operator when the modulation signal is not set to 1V peak ($\pm 2\%$ typically). The external modulation signal is compared in the dual-comparator, U16, with internal references of 0.98 and 1.02V. Two status bits, MLEVLO and MLEVH1, are at the output of the 0.5-second dual one-shot, U17. If either of these reference voltages are exceeded, the two status bits are sensed by the Generator Controller that controls the EXT HI and EXT LO indicators in the MODULATION display field.

3-40. Switch PCB, A1A2

All the front panel control keys, except the POWER ON/OFF switch, consist of an elastomeric membrane sandwiched between the Switch PCB A1A2 and the front panel sheet metal housing. The Switch PCB consists of a 6-by-8 matrix of open switch contact pads. When a key is pressed, a conductive pad on the back of the elastomeric membrane connects a set of contact pads. The Controller software senses which row and column of the matrix are connected when a key is pressed.

3-41. MODULE SECTION, A2

The module section consists of a cast module frame with gasketed covers and includes the following electrical assemblies:

- A2A1, Synthesizer
- A2A2, VCO
- A2A4, Output
- A2A5, Attenuator/RPP
- A2A7, Controller

3-42. Synthesizer PCA, A2A1

The Synthesizer PCA provides frequency control and modulation of the Generator's output. The Synthesizer assembly is located on the top side of the module section A2. Together with VCO A2A2 and an optional 10-MHz external reference frequency, the Synthesizer assembly simultaneously generates a high-band signal that spans 490 to 1050 MHz and a mid-band signal that spans 245 to 525 MHz. The maximum programmed VCO frequency is 1044.99999 MHz, which corresponds to 244.99999 MHz in the low band.

The high-band and mid-band signals are coupled to the Output assembly, A2A4. Here, heterodyning extends the Generator frequency coverage down to 0.01 MHz.

The Synthesizer assembly consists of the following functional circuits, which are described in the following paragraphs:

- 10-MHz Reference
- Main PLL
- FM Processing
- 800/40 MHz PLL
- Sub-Synthesizer

3-43. 10-MHZ REFERENCE

The 10-MHz Reference circuitry allows internal or external signals to function as the Generator reference. The Generator reference is normally the internal 10-MHz crystal oscillator. The internal 10-MHz crystal oscillator (X.O.) is a crystal, Y1, and an FET transistor Q26. The frequency is adjusted by C153. The oscillator signal from Q26 is buffered by Q27, converted to TTL by U54, and sent to multiplexer U55A. When the

internal oscillator is disabled, the input (U54 pin 13) is pulled up at the same time the bias current for Q26 is disabled. The A section of this multiplexer decides whether the internal 10-MHz X.O. or the external reference is selected for the Generator reference.

The output of multiplexer U55 is sent to the 800/40-MHz loop phase detector and the main loop phase detector via divide-by-50, U58. Multiplexer U55B sends the signal to the rear panel if the REF INT/EXT switch is set to INT.

The rear panel 10 MHz IN/OUT connector serves two functions:

1. When the rear panel REF INT/EXT switch is set to INT, the 10-MHz reference signal from the X.O. is the Generator's reference.
2. When the rear panel REF INT/EXT switch is set to EXT, an external 10-MHz TTL signal applied to this connector becomes the Generator reference.

3-44. MAIN PHASE-LOCK LOOP

The main phase-lock loop (PLL) is a fractional divider PLL with a single-sideband mixer (SSB) in the feedback path. The oscillator for this loop is a separate PCA, the A2A2 VCO. All the remaining PLL circuitry is on the Synthesizer PCA A2A1.

The key signals to the main PLL are the 0.2-MHz reference signal from the 10-MHz Reference circuit, the 245-MHz to 525-MHz signal from the binary divider, and the 10-kHz to 20-kHz signal from the sub-synthesizer circuit. The fractional division technique provides 10-kHz frequency resolution.

The SSB mixer, in conjunction with the sub-synthesizer, provides additional 2.5-Hz resolution on the mid band. This corresponds to 5-Hz resolution on the low band, although only 10-Hz resolution is displayed.

The main PLL consists of the VCO, the binary divider, the SSB mixer, the triple-modulus prescaler, the N-Divider, the phase detector, and the loop amplifier. All but the VCO are described in the following paragraphs. The VCO is discussed in the VCO PCA, A2A2 paragraph in this section.

3-45. Binary Divider and Single-Sideband Mixer

The 490-MHz to 1050-MHz signal from the VCO via J107 is coupled to the binary divider, U1. Regulator Q1 provides +5V for the divider. One output of U1 is coupled to the Output PCA, A2A4 through J104. The other output is amplified by Q2 and Q3. This signal is split into two quadrature (90° phase difference) signals by 3-dB coupler, U6.

This signal, and two other audio quadrature signals from U10, are summed in the double-balanced mixers U7 and U8 to produce two double-sideband suppressed-carrier signals. Because of the phase relationship of the outputs of the mixers, the summing of the two composite signals (in resistor network R21 and R22) results in the upper-sideband component being suppressed. The predominate remaining signal is the lower-sideband signal.

The lower-sideband signal, spanning 245 MHz to 525 MHz in 10-kHz steps, is amplified by U9 and applied to the N-Divider where it is divided down to 0.2 MHz.

3-46. N-Divider

The main components of the N-Divider are:

- Triple-Modulus Prescaler (divide by 20/21/22) U18, U19, and U20
- N-Divider Custom Gate Array U17
- Divide by 5 U14

The triple-modulus prescaler, Figure 3-1, consists of a divide by 10/11 (U20), divide by 2 (U18A), synchronizing flip-flop (U18B), and quad NOR gates (U19). If all the inputs (E1, E2, E3, E4, and E5) to the 10/11 divider are low, the prescaler divides by 11, and the total division to the output (U20 pin 7) is 22. If any of the inputs are high, it divides by 10, and the total division is 20.

If inputs E1 and E3 are low, the modulus of the 10/11 divider is controlled by the output of the following divide-by-2 (U18A). Consequently, the prescaler divides by 10 half the time and by 11 the other half, resulting in a divide by 21. U20 contains the ECL-to-TTL converter. U18B synchronizes the changing of the modulus with the clocking of the subsequent stages. The N-divider gate array is clocked by the composite prescaler output U18A.

The operation of the triple-modulus prescaler is shown in Figure 3-1. The prescaler operates in conjunction with the N-divider gate array shown in Figure 3-2.

The N-Divider gate-array contains two 5-bit binary up counters (A and N), a BCD two-decade rate multiplier, and latches to interface to the microprocessor. The operation of the N and A counters is as follows:

At the beginning of a count cycle, a number is loaded into the A and N counters. The A counter is not at its terminal count, so the output is high, and the mode line (MODE L) is low. This causes the prescaler to divide by 21 (or 22, TRMODL = low). The mode line stays low for 31-A counts, where A is the programmed number. The mode line goes high, and the prescaler divides by 20 (or 21, TRMODL = low) for 31-N counts.

The total division for the triple-modulus prescaler and N-Divider gate-array is:

$$(P+1)*(31-A) + P*((31-N)-(31-A)) \text{ or } P*(31-N) + (31-A)$$

On the 31st count, the counters are reinitialized. Figure 3-3 shows the timing for the A-counter programmed to 26, and the N-counter programmed to 18. Only the CKNL and MODE L signals shown in Figure 3-2 are accessible at U17, pins 6 and 22, respectively.

The N-Divider gate array includes a two-decade rate multiplier that produces the fractional part of the division. It produces a pulse train with a programmed number of pulses for a 100-cycle frame of the 1-MHz N-divider gate-array output.

The programmed number ranges between 0 and 99, corresponding to 10-kHz steps at the mid-band output frequency. The flip-flops in the rate multiplier get set up on count 29; on count 30, a pulse may or may not be present, depending on the programming of the rate multiplier. This is the shaded pulse in the timing diagram, Figure 3-3.

Irregularly spaced rate-multiplier pulses cause the mode line to go low, and the prescaler divides by P+1 at a rate equal to the rate multiplier programming.

It might be noted that a 20/21 dual-modulus prescaler does not allow division from 245 to 525 without holes. For example, 252 is 0 frames of 20 and 12 frames of 21. Consequently, there is no place to slip in the rate-multiplier pulses. It is not possible to divide by 253.

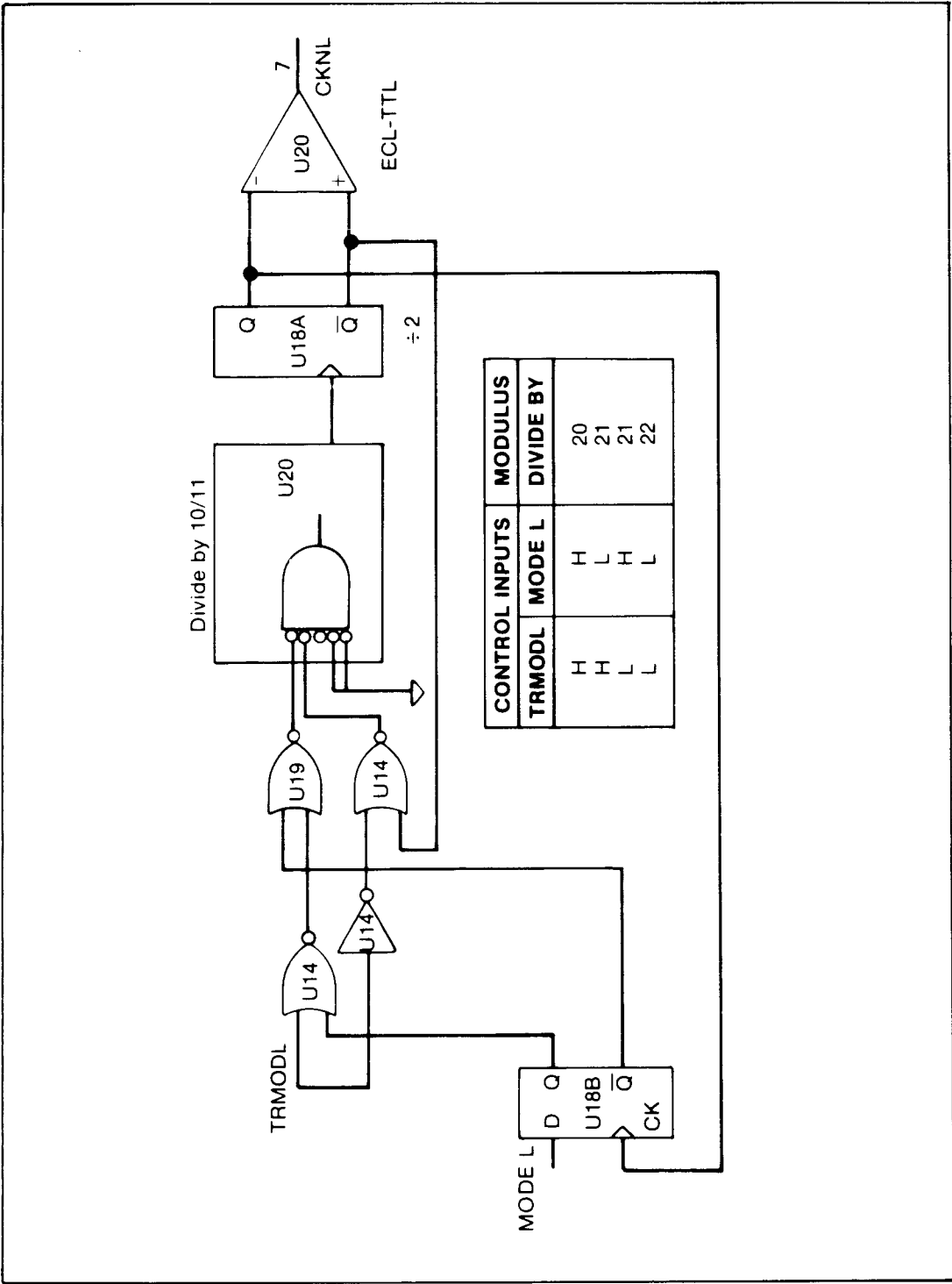

Figure 3-1. Triple-Modulus Prescaler Operation

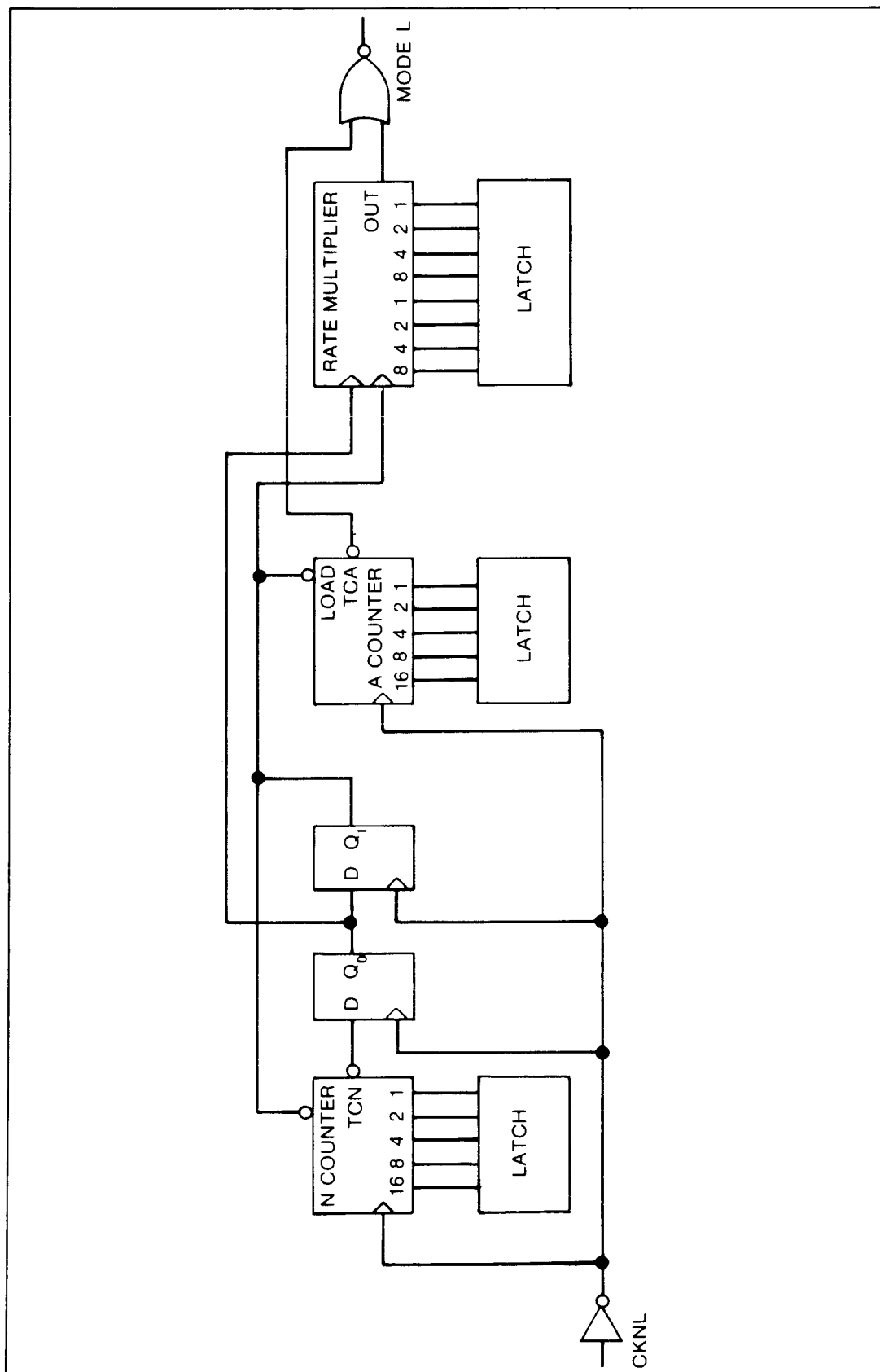

Figure 3-2. N-Divider Operation

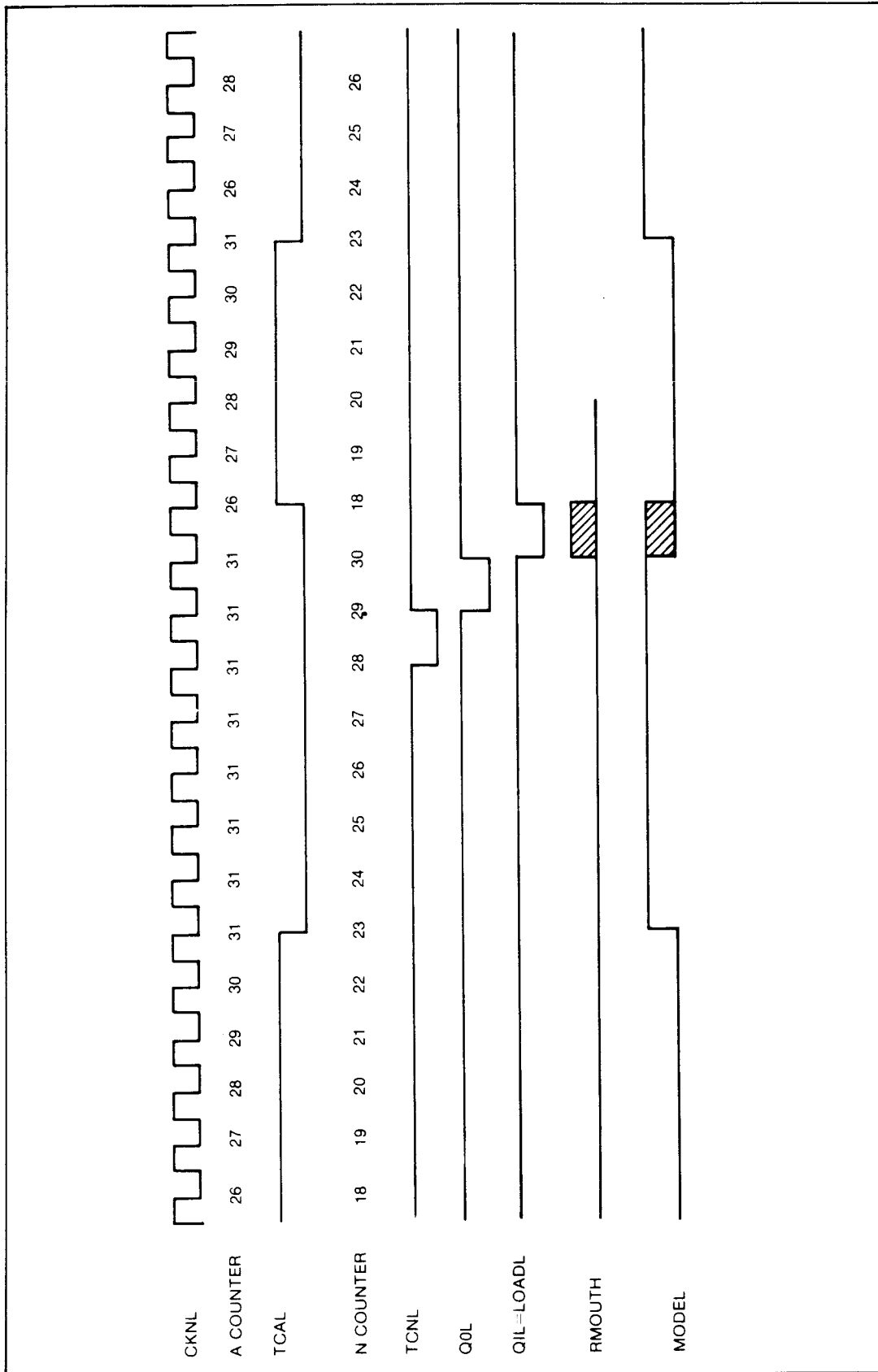

Figure 3-3. N-Divider Timing Diagram

By using a triple-modulus prescaler, these problems are solved. Continuing with the previous example, 252 is 12 frames of 21 and 0 frames of 22. The deleter functions by allowing the prescaler to divide by 22 at a rate equal to the rate-multiplier frequency. Thus, 253 is 11 frames of 21 and 1 frame of 22. A software algorithm determines whether to operate in the 20/21 mode (TRMODL =1) or 21/22 mode (TRMODL =0).

The frequency at the output of the N-divider gate array, U17, is $(F_o/2 - F_s - F_d)/N$, where F_o is the VCO output frequency, F_s is the sub-synthesizer frequency, and F_d is the fractional-division frequency. The frequency at the output of the N-divider gate array is divided again by 5 in U14. This frequency is 0.2 MHz, the same as the reference frequency. There is a corresponding divide-by-5 in the reference path, so the net effect is that the output frequency of the N-divider gate array, U17, is 1 MHz. The purpose of the divide-by-5 is to increase the allowable FM deviation at low rates.

3-47. Phase Detector

The 0.2-MHz reference signal from divide-by-50 U58, and the 0.2-MHz signal from the last stage of the N-divider, U14, are connected to a digital phase-frequency detector (U43, U44, U45, U47).

If the phase of the clock input of U44A, from the N-divider leads the phase of the clock input of U43A, from the reference, the Q output of U44A is set high. When a positive edge clocks U43A, its Q output goes high and immediately clears U44A and U43A via U45. The width of the U44A Q output pulse is proportional to the phase difference between the N-divider and reference clocks. If the phase difference between the N-divider and reference clocks is lagging, the width of the U43A Q output pulse is proportional to the phase difference.

A conventional digital phase-frequency detector has a range of $\pm 2 \pi$ radians. By addition of another section, consisting of U43B, U44B, U45, and U47B, the range is increased to $+4 \pi$, -2π radians.

As the phase difference approaches 2π radians, the pulse width at the Q output of U44A approaches 100%. This pulse-width output, delayed through gates U45B and an RC network (R117, C137) causes the Q output of extension flip-flop U44B to go high. This causes one-shot U47B to clear flip-flop U44A through the OR function of U45A, which then causes the main phase detector, U44A and U43A, to reset back by 2π radians. The extension flip-flop, U44B, controls an extension down-pump, consisting of current source U67B, level shifter Q44, and diodes CR28 and CR29. When the main phase detector is reset, this provides a current equivalent to 2π radians. As the phase difference changes more in the same direction, the range extends an additional 2π radians. As the phase returns back from the extended region, the pulse width from flip-flop U43A begins to increase. This allows a control flip-flop, U43B, to become active and to clear the extension flip-flop and preset main flip-flop U44A. This presets the main phase detector to 2π radians at the same time the extension flip-flop is cleared. The extension flip-flop, U44B, and control flip-flop, U43B, are synchronized with the clock input to the main phase detector flip-flop, U44A.

If the N-divider output frequency is greater than the reference frequency, the level at TP38 is high. When the output of the level shifter Q16 is above ground, CR12 is turned off. This allows current from U76A, a matched pnp transistor, to flow through CR13 into the integrator, decreasing the voltage at the integrator output (U48 Pin 6), which then lowers the frequency of the VCO until the reference and the N-divider output are the same frequency.

Similarly, if the N-divider output frequency is below the reference, then TP39 is low, and the voltage at the output of level shifter Q17 is below ground, turning off CR15 and allowing current from Q39 to flow through CR14 out of the integrator. This raises the voltage at the output of the integrator, which raises the VCO frequency.

R107 provides an offset current to the integrator to bias the phase detector at approximately $-\pi$ radians; consequently, the down-pump is normally always on. This allows a total phase detector range of $\pm 3\pi$ radians. If the up-pump comes on, indicating phase detector excursions greater than $\pm \pi$, the pulses are detected by the one-shot, U47A, that produces the UNLOCK status which is then sensed by the Controller. This is ignored while FM modulating.

For flat FM response, it is necessary for the PLL bandwidth to be constant at all VCO frequencies. Two factors cause the loop bandwidth to change: the VCO tuning coefficient (K_v) and the divider ratio (N).

During calibration of the VCO, the K_v is measured at many frequencies across the band, and compensation data is stored in the VCO Calibration EPROM. The instrument software uses this data along with N to control the PLL bandwidth in a compensating manner. The PLL bandwidth is controlled by changing the current to the down-pump via the KN DAC, U27, and the voltage-to-current converter, U46, Q18, and U67A. When FM modulating at high deviations and low-rates, the up, down and offset pumps are used. The pump currents are balanced to minimize fm distortion. Q39, Q40, and Q41 mirrors the current from Q38. Dual pnp U67 provides the down-pump current and down-pump offset current.

3-48. Loop Amplifier

The loop amplifier-integrator consists of operational amplifier U48, C118 and R91. Capacitors C121 and C119 filter the 0.2-MHz reference. The output of the integrator is connected to a multi-pole LC filter (R92, C123, C99, C124, C126, C125, C237, L49, L50, L51 and R93) which attenuates the delete rate (10 and 20 kHz) and the reference 0.2-MHz spurs.

Diodes CR9 and CR10 stabilize the loop during switching. The filter is buffered by the Darlington emitter-follower Q20, which is biased at 10 mA by Q21. Additional lead/lag compensation is provided by R99, R101, and C131. Proper termination for the filter is provided by R93 and Q22. The voltage for the loop amplifier is regulated to approximately +30V by Q15.

Amplifier U49 is a precision clamp that keeps the VCO frequency above a minimum value for oscillation, and below a maximum above which the N-divider would not divide correctly. The photoisolator U50 detects when the clamp is active, indicating an out-of-lock condition. This signal is ORed with the signal from one-shot U47 and sent to the microprocessor as the UNLOCK status.

3-49. FM PROCESSING

To provide FM accuracy, the FM signal FMV from the Output board is first processed by the KV DAC (U28 and U29) to compensate for the VCO tuning coefficient. The KV DAC setting is proportional to $1/K_v$, where K_v is the tuning coefficient. This correction is stored in the VCO Calibration EPROM on the Controller board. For output frequencies below 245 MHz, the KV DAC setting is halved to account for the effective frequency doubling that occurs on this bands.

THEORY OF OPERATION

Range switching is provided by resistors R77, R78, and R79, and FETs Q10, Q11, and Q12. Comparator U42 converts TTL levels to 0V (on) and -15V (off), the levels required by the FETs. U41A buffers the range switch, and in conjunction with R82, provides an overall FM adjustment. At this point, the audio signal splits into two paths. The path that connects to the integrator, U41, is for modulation frequencies inside the loop bandwidth. The path that sums with the VCO control voltage at J103 is for frequencies outside the loop bandwidth. U41D is an active high-pass filter that compensates for the non-ideal integrator and the ac coupling to the VCO tuning port.

The output of U41D is summed with the VCO control voltage via R88 and C117. FET Q13 allows the FM to be turned off. The audio signal is also processed by integrator U41A, R85, R86, and C115. The audio signal is ac coupled into the phase-detector integrator via R89, R90, C116, and FET Q14. (Resistor R90 adjusts the low frequency FM gain.) This integrator causes the phase modulation produced at the Phase Detector to appear as FM.

3-50. 800/40 MHz PLL

When the Signal Generator is operated in the low band, the 800-MHz oscillator is locked to the 10-MHz Reference and provides a local oscillator for the heterodyne circuit on the Output PCA. It also provides a 40-MHz signal to the sub-synthesizer clock generator.

The 800-MHz VCO is connected to the divide-by-four, U61, followed by a divide-by-five, U62 and U63, providing 40 MHz to the sub-synthesizer clock generator through selector U64. When the Generator is not in the low band, the 800-Hz oscillator and the first divide-by-four are disabled by turning off Q28 (HET).

The 40-MHz oscillator, consisting of U64, L66, and CR24, is selected by U64. The 40-Hz balanced ECL signal from U64 drives the two-phase clock generator. A self-biased gate, U65, converts ECL to TTL. U66 divides the 40-MHz signal by four to produce a 10-MHz signal that is compared against the 10-MHz Reference in the phase detector U59 and U65.

Op amp U60, resistor network Z9, and C181, C185, C186, and C201 integrate the phase detector pulses to produce a dc control voltage for the 800-MHz VCO and the 40-MHz VCO.

3-51. 800-MHz VCO

The 800-MHz VCO is a low noise, limited range, voltage-controlled oscillator for the 800-MHz PLL. The basic oscillator uses two active devices operating as negative resistance elements, coupled symmetrically to a resonator made up of a varactor and an adjustable capacitor. Each device is followed by an amplifier and isolation pad. This provides two coherent outputs of +5 dBm to the PLL and 0 dBm to the output A2A4 assembly.

The oscillator transistors Q32 and Q35 are biased at 13 mA by R182 and R191. The voltage at the collectors of Q32 and Q35 is typically +2.5V. The two 6-dB amplifiers Q33 and Q37 are biased so that the voltage at their emitters is about +0.3V, and the voltage at their bases is about +1V, with the collectors at +6.5V.

The PLL control voltage from U60 provides the tuning voltage for the varactor CR27. The adjustable capacitor C206 is set to provide +16V on the varactor to optimize the VCO noise characteristic. The output attenuators R186, R187, R189, R197, R198, and R200 provide isolation between the outputs. The VCO signal is coupled to the output assembly A2A4 by a through-the-plate coaxial connector P108 at the 0-dBm level. The other VCO signal is connected to the divider U61 to provide the feedback for the PLL.

3-52. SUB-SYNTHESIZER

The sub-synthesizer consists of the clock generator, U34, 35, Q4, Q5, the gate-array, U33, the divide by 1000, U15, and U16, and the low-pass filter L11 and L17. Internal to the sub-synthesizer gate-array, U33, are a divide-by-two, a 3-½ decade-rate multiplier, and associated latches.

The balanced 40-MHz ECL clock signal is converted to TTL in Q4 and Q5, and converted to a two-phase 20-MHz clock in U34, U35.

An enable output of each section allows multiple sections to be cascaded. The input frequency to the rate-multiplier is 20-MHz. The output frequency can be programmed from 0 to 19.995 MHz in 5-kHz steps. This signal is ORed with the other phase of the 20-MHz clock to produce 20 MHz to 39.995 MHz at U33 pin 1. This is divided by two in the gate-array, by ten in U15, and again by 100 in U16 to produce 10 kHz to 19.9975 kHz in 2.5-Hz steps. Only 5-Hz steps are used internally, corresponding to 10-Hz steps at the output. This TTL signal at TP11 is filtered by L11, L17, and C41, C42, C48, C50, and C51. Op amp U10 forms an active quadrature generator, and the output pins 14 and 8 are offset by 90°. These two signals are the 10-kHz to 20-kHz inputs for the Main PLL single-sideband mixer.

3-53. VCO PCA, A2A2

The VCO PCA A2A2 is the heart of the main PLL. It produces the signal that is further processed to become the Generator output. The VCO assembly is located in a bottom side compartment of the module section, A2.

The VCO tunes over a frequency range of 490 MHz to 1050 MHz with a control voltage range of +2V to +18V. The basic oscillator circuit uses two active devices operating as negative resistance elements. Coupled symmetrically to a resonator, each active device is followed by a 6-dB amplifier and a 15-dB isolator pad that provides two coherent but isolated signals at about 0 dBm.

One signal is sent to the Output A2A4 assembly, and the other to the Synthesizer A2A1 assembly. To suppress harmonics, two tuned trap filters are placed between the negative resistance devices and amplifiers Q2 and Q4.

The oscillator transistors Q1 and Q3 are biased at 13 mA. The voltage at the collectors of Q1 and Q3 are typically set at +6V. The two 6-dB amplifiers Q2 and Q4 are biased so that the voltage at their emitters, is about +0.3V and at their bases about +1V, with the collectors at about +6.5V.

The PLL control voltage from the Synthesizer assembly A2A1 at P102 provides the tuning voltage for varactors CR1 and CR2. This voltage also controls varactors CR3 and CR4 with resistors R6, R4, R18, R19, and R20. These varactors, in conjunction with their lead inductance and C1 and C32, make up a shunt trap filter at twice the VCO frequency to suppress the in-band second harmonic at both VCO outputs to typically less than -10 dBc.

The output attenuators consisting of R13, R14, R15, R27, R28, and R29 provide the isolation between the two VCO outputs at P103 and P104. C23 and C30, in series with the printed board inductors, form out-of-band trap filters for approximately 1.4 GHz. These filters further suppress the out-of-band harmonics.

C23 couples the VCO signal to the Synthesizer assembly by a through-the-plate coaxial connector P104. The other VCO signal is connected to the Output assembly A2A4 by a

plug-in capacitor, A2C1. This plug-in capacitor allows either VCO or the Output PCA to be removed independently from the module A2 assembly without the use of a soldering iron.

3-54. Output PCA, A2A4

The Output PCA accepts RF signals from the Synthesizer and the VCO circuits and command signals from the Controller. The output circuit provides a 0.01-MHz to 520-MHz RF signal to the Attenuator.

The Output assembly reduces harmonic distortion components in the RF signal, controls RF signal amplitude, introduces AM, and generates the low (heterodyne) frequency band 0.01 MHz to 245 MHz through mixing. It also generates a modulation signal to provide internal AM and FM, and provides a digital interconnect path between the Controller and Synthesizer.

3-55. RF PATH

The RF path begins with the two RF signals from the VCO and the Synthesizer assemblies. The SPDT bandswitch circuit selects between the 800-MHz to 1045-MHz signal at P106 and the 245-MHz to 525-MHz signal at P107. The selected signal is applied to buffer amplifier Q101 and Q102.

The 245-MHz to 525-MHz signal directly generates the 245-MHz to 525-MHz mid-band output signal. The 800-MHz to 1045-MHz signal generates the 0.01-MHz to 245-MHz low-band output signal by mixing with an 800-MHz LO signal.

The buffer amplifier Q101 and Q102 is a common-base, common-emitter cascade circuit with 7-dB gain. The three cascaded filter circuits that follow the buffer amplifier consist of combinations of discrete components and printed filters that suppress harmonics in the Generator RF output signal.

The first section of the circuit is a printed 1100-MHz low-pass filter. The second section is switched into the RF path via PIN diodes CR106 through CR110 by asserting MIDL when the Generator is operated in the mid band (245 to 525 MHz). PIN diodes CR114 through CR116 select capacitors C119, C121, and C123 whenever HAOCTH is asserted to change the section cutoff frequency from 512 to 350 MHz. The third section provides harmonic filtering for the RF signal, 800 to 1045 MHz, used to generate the low band.

The amplitude modulator consists of PIN diodes CR117 through CR120 and associated components, and follows the switchable filters in the signal path. The modulator is a voltage-controlled variable attenuator that provides AM and output level control. Modulator control voltage is determined by the leveling-loop circuitry. The leveling loop is described later in this section.

Q209, Q211, Q213, and associated components follow the modulator in the signal path and form a three-stage, 20-dB gain, 245-MHz to 1050-MHz amplifier. This amplifier drives a 3-dB power splitter that consists of resistors R253 through R255 and associated printed transmission lines.

One power splitter output drives the leveling-loop detector diode CR202. The other output goes to the HET band switch that includes PIN diodes CR203 through CR210 and biasing components. In the 245-MHz to 525-MHz position, the signal passes through diodes CR204 through CR209 to the output amplifier Q215. This low-distortion output amplifier has 6-dB gain and output capability of 15 dBm.

For low-band operation (0.01 MHz to 245 MHz), the signal from the power splitter is routed through CR203 to an adjustable attenuator, R224 through R229, and then to the RF port of U201 (a double-balanced mixer). The signal frequency at the mixer RF port varies from 800.01 MHz to 1045 MHz. The 800-MHz local oscillator (LO) signal for the mixer comes from the Synthesizer assembly through P108 and is amplified by Q207. This fixed-tuned amplifier has 13 dB of gain and provides a 10-dBm signal at the mixer LO port.

The mixer 0.01-MHz to 245-MHz output signal is passed through a diplexing low-pass filter (C219 through C230, R230, R231) that suppresses unwanted mixer spurious products while maintaining a 50-ohm load at the mixer IF port. The filtered IF signal is amplified by a three-stage IF amplifier Q202, Q204, Q206 and associated components.

The IF amplifier gain increases with frequency and is nominally 35 dB at 0.01 MHz and 37 dB at 245 MHz. This gain characteristic compensates for the increasing loss with frequency of the mixer and the diplexing low-pass filter. The output of the IF amplifier passes through a 245-MHz low-pass filter (C216, C217, C218 and printed inductors) and PIN diode CR210 to the output amplifier. The +15V power supply for the LO and IF amplifiers is switched off by Q301 when the instrument is operating in the 245-MHz to 525-MHz band to avoid introducing spurious products into the instrument output.

3-56. LEVELING LOOP

The leveling loop accepts the unlevelled 245-MHz to 1050-MHz signal from the switchable low-pass filters and generates a leveled signal at the power splitter output that feeds the HET band switch. The leveled signal is proportional to the leveling loop control voltage that is generated by the level-control circuit. The signal amplitude at the other output of the power splitter is detected by a Schottky detector diode, CR202.

This diode generates a temperature-dependent dc voltage, which is a non-linear function of the applied RF voltage. Therefore, temperature compensation and linearization are necessary. The detector diode signal is low-pass filtered by L217 and C253, and is offset by the voltage across temperature-compensating diode CR126. Q104, Q105 and associated components form a current source circuit that provides bias current for CR126 and CR202.

The offset detector diode voltage at U101B pin 3 is linearized by amplifier U101B and its associated feedback components. Potentiometer R144 provides detector linearity adjustment. Thus, the voltage at U101B pin 1 is proportional to the RF voltage at detector diode CR202.

This voltage is divided and applied to the loop integrator amplifier at U101A pin 6. This amplifier drives the modulator through emitter-follower Q103 and through the action of the ALC loop, maintaining the voltage level at U101A pin 6 equal to that on pin 5. The voltage at pin 5 is a function of the leveling loop control voltage applied to R140. R140, R141, CR127, and CR128 form an additional detector linearizing network that is active for low RF levels. Amplitude modulation is achieved by summing an appropriately scaled modulation signal with the dc leveling loop control voltage applied to R140.

The amplitude modulator consists of PIN diodes CR117 through CR120, resistors R121, R122, and capacitors C137 and C138. Attenuation through the modulator is a function of bias current through the PIN diodes. This current is provided by the modulator linearizer circuit (R123 through R129, R148, R149, C139 through C143, and CR121).

Modulator attenuation is thus approximately proportional to the modulator control voltage at the emitter of Q103. Proportionality is required to maintain constant leveling

loop bandwidth as modulator attenuation varies. Minimum attenuation is obtained with a modulator control voltage of 10V, while maximum attenuation is obtained with 0V.

Comparator U310A and associated components form an unlevelled indicator circuit. The comparator senses the modulator control voltage at the emitter of Q103. This voltage is normally less than +11V, and the comparator output is high. If the modulator control voltage exceeds +11V, the modulator attenuation is at a minimum, and the leveling loop becomes inoperative (unleveled). This condition could be due to a fault or some abnormal operation such as over-modulation. In this case, the comparator output (UNLVLL) goes low. The Controller senses this low and causes the front panel UNCAL indicator to flash and displays an unlevelled status if interrogated.

3-57. LEVEL CONTROL

The instrument output level is set by the level-control circuit. Inputs to this audio signal processing circuit are the internal and external modulation signals, a dc reference voltage, and the digital control commands. The circuit output is the leveling loop control voltage that provides vernier level control of the Generator output. Digitally encoded level, modulation depth, and temperature-compensation information are provided by the Controller.

Selection of the internal or external modulating signal, or no modulation, is made by analog switches U401C, U401D, and op amp U402B. The selected, buffered modulation signal at U402B pin 1 is applied to pin 4 of U301, a dual 8-bit DAC. U301, with U302D, acts as a digitally programmed variable attenuator and is labeled AM DAC.

Binary AM depth control information from the Controller is applied to DAC U301. The output at U302D pin 14 is the modulation signal scaled to the programmed AM depth. This ac signal is summed by op amp U302B with a dc reference voltage provided by CR403. The output at U302B pin 7 is called the 1+AM signal. This signal provides the desired AM depth when scaled by the LVL DAC and applied to the leveling loop. AM depth adjustment is provided by potentiometer R421.

The instrument RF output amplitude is temperature compensated in a frequency-dependent manner as follows: The 1+AM signal is applied to pin 18 of dual 8-bit DAC U301, the DAC B reference input. The DAC output, at U405D pin 14, is the 1+AM signal attenuated by an RF frequency-dependent factor provided by the Controller using constants stored in the Generator firmware. This voltage is applied to a resistor/thermistor network that includes R303, R305, R306, and RT301.

The network output is the 1+AM signal attenuated by an RF frequency and temperature-dependent factor, and is applied to summing op amp U302C. The 1+AM signal is also applied to this summing amplifier. Thus, the voltage at U302C pin 8 is the temperature-compensated and scaled 1+AM signal.

This signal is applied to the reference input of Level DAC U303. This 12-bit DAC, with op amp U302A, latches U304, U305, and controls the Output assembly RF output amplitude. The DAC output voltage, at U302A pin 1, is the temperature-compensated 1+AM signal multiplied by a factor proportional to the 12-bit level control number provided by the Controller. This voltage is the leveling loop control voltage. The Generator RF output level adjustment is provided by potentiometer R311, and DAC offset voltage adjustment is provided by potentiometer R309.

3-58. MODULATION OSCILLATOR

The modulation oscillator generates a leveled sine wave of 400 Hz or 1 kHz and is the modulation source for the internal AM and FM functions. The oscillator is a level-controlled Wien-Bridge type and consists of op amps U405A, U405B. Frequency is determined by the series RC time constant of the components between pins 5 and 7 of U405B and by the parallel RC time constant of the components from U405 pin 5 to ground. The modulation frequency control line, MF400L, originating at latch U308, selects either 400-Hz or 1-kHz operation, and is selected by switching resistors with JFETs Q401 and Q403.

The amplitude of oscillation is controlled by an ALC loop that varies the resistance on U405B pin 6 to ground. This resistance, comprised of R412 and the drain resistance of Q402, is nominally 2 kilohms. The oscillator signal amplitude is sensed by rectifier CR401. The average current through CR401 is made equal to the reference current in R416 by integrator-amplifier U405A. Level adjustment is set by potentiometer R419. Temperature compensation is provided by R417, R418, and CR402.

3-59. FM DEVIATION CONTROL

The FM modulation signal source and deviation control circuits are on the Output assembly. Analog switches U401A, U401B, and op amp U402A select the internal or external modulating signal, or no modulation. The selected and buffered modulating signal at U402A pin 7 is applied to FM DAC U403. This DAC provides fine control of the FM deviation. (The coarse control FM circuitry is part of the Synthesizer assembly.) The output of the DAC, at U405C pin 8, is the modulation signal multiplied by a factor proportional to the 8-bit FM deviation control provided by the Controller.

3-60. Attenuator/RPP PCA, A2A5

The Attenuator/RPP A2A5 consists of an Attenuator/RPP PCA, A2A5A4, in a metal housing mounted on the top side of the A2 module section to form a shielded enclosure. The Relay Driver PCA, A2A5A5, is included in this assembly.

The Attenuator assembly controlled by the microprocessor provides coarse control of the Generator output level. The high-level signal from the Output assembly, A2A4, is applied to the Attenuator, which provides 0 dB to 138 dB of attenuation, in 6-dB steps, to this signal before it goes to the Generator RF OUTPUT connector.

Compensation data for the Attenuator in each Generator is stored in the Attenuator calibration EPROM located on the Controller PCA, A2A7. The instrument program uses this data to correct for the combined deviations of the attenuator sections in use. For more details on level correction, refer to the Amplitude Control paragraph in this section.

The Attenuator assembly provides an attenuation range from 0 dB to 138 dB in 6-dB steps and consists of seven independently cascaded 50-ohm attenuation sections, a 6-dB section, a 12-dB section, and five 24-dB sections. Each section consists of a DPDT relay and a three-resistor attenuator pad.

One relay position (when power is applied to the relay) provides a straight path for the RF signal, and the other position (no power applied to the relay) inserts the attenuator pad into the RF signal path. All seven relays are inside individual shielded compartments in the Attenuator housing.

The control of the Attenuator relays is latched via U27, the open-collector drivers U30 and U31 on the Controller PCA A2A7 and transistor drivers on the A2A5A5 Relay

Driver PCA. For calibration and troubleshooting purposes, special functions 83 through 86 allow the direct selection of four of the five 24-dB attenuators. The other 24-dB attenuator is selected by programming the appropriate level (-12 dBm).

Coupling capacitors C6 and C7 protect against dc or low-frequency power. The diode limiter, consisting of CR2 through CR9, provides protection against medium RF power levels and short-term (fast acting) protection against high RF power levels. Long-term (latched) protection is provided by relay K8 whenever the reverse RF power exceeds a preset level.

RF power detected by CR1 is compared with the preset voltage in one section of comparator U1. When the detected voltage exceeds the set value, the output of U1 pin 1 goes positive, turning on Q1 and Q2. This actuates K8 to the protect position. In the protect position, the output connector is shorted to ground and the Generator output is disconnected from the output connector.

CR15 and R6 form a latching network such that K8 remains in the protect position until the Generator RF Output is reset by an RF ON entry. The output of the comparator is buffered and sent as RPTRPL to interrupt the Controller signal that annunciates the RPP trip condition by flashing the UNCAL and RF OFF indicators.

3-61. Controller PCA, A2A7

The Controller, under the direction of the instrument software, handles the data interface between the front panel, remote interface, and Generator functions. The Controller is located in a top side compartment of the module section, A2.

The Controller printed circuit assembly consists of the following functional groups:

- Microprocessor and its interface circuitry
- Attenuator control interface
- Front panel interface
- IEEE-488 Interface
- Memory ICs and addressing circuitry
- Module I/O circuitry
- Reset circuit
- Status and control latches

3-62. MICROPROCESSOR

The heart of the Controller assembly is U1, a TMS9995 16/8 bit microprocessor. The digital system clock signal is generated by an oscillator comprised of gates from U5 and crystal U41. When enabled, bidirectional buffer U4 provides additional drive current for data bus operation; when it is disabled, it isolates the microprocessor from the system data bus. Buffers U33, U34, and U10 provide extra drive current to the microprocessor address and control signals.

3-63. ATTENUATOR CONTROL INTERFACE

The attenuator control signals are latched by U27. Darlington drivers U30 and U31 control the Relay Driver A2A5A5 PCA.

3-64. FRONT PANEL INTERFACE

Data is transferred to and from the front panel circuitry through tri-state bidirectional data buffer U18. This buffer is active when a front panel latch is addressed and the buffer

control signal from U17 is low; otherwise, it is in the high-impedance state. The front panel latch select lines are decoded by U36. To reduce RF emissions from the Generator, low-pass filters comprised of the following components are used on the following signals:

SIGNALS	COMPONENTS
Signal CLRL	R6 and C51
Latch select SEG1L	R7 and C53
Latch select SEG2L	R8 and C54
Latch select SEG3L	R9 and C55
Latch select SEG9L	R10 and C56
Latch select DIGL	R11 and C57

In addition, capacitors C58 and C59 bypass the display filament supplies. LC filters comprised of L1 and C50, and L2 and C52 are used on the +5 volt and +37 volt supplies to the front panel circuitry.

3-65. IEEE-488 INTERFACE

Tri-state bidirectional buffer U2 buffers the data bus to the IEEE-488 assembly, A3A3. Address and control lines to the option are buffered by tri-state buffer U3. These buffers are in the high-impedance state when the option is not addressed.

The active-low interrupt signal IEINTL from the IEEE-488 assembly is connected to the level-four interrupt on the microprocessor. R1 and C22 form a low-pass filter to suppress digital emissions from the Generator.

3-66. MEMORY

The microprocessor uses a 2K-byte RAM (U25) to store program variables. A 32K- and a 16K-byte EPROM (U21 and U22) contain the microprocessor instructions and constant data. Three 2K-byte Calibration EPROMs (U23, U24, U26) contain calibration data for the VCO, Output, and Attenuator/RPP assemblies, respectively. Decoders U20 and U14 decode the individual chip selects for the memory ICs.

3-67. MODULE I/O

Control data is transferred to the RF circuitry (located in the Module Section, A2) through a byte-wide unidirectional data bus. This data is retained on the RF circuit boards in latches. Select lines BSEL0L, BSEL1L, and address lines BAB2 through BAB0 are decoded into individual latch enables on the various RF circuit boards. Tri-state buffers U15 and U16 on the data and address lines provide extra drive current and allow these signals to float when inactive.

Flip-flop U42 gates the module I/O select pulse from U8 with the system clock to delay the leading edges of BSEL0L and BSEL1L to provide adequate latch setup times. D-flip-flop U9 latches address lines BAB2 through BAB0 to provide adequate latch hold times.

3-68. RESET

Comparator U7 and its associated circuitry generate the active low reset signal to the TMS9995. The reset signal is generated on power-up or if the +5V supply drops below +5V.

At power-up, R5 and C4 provide a slow-rising reset signal to the microprocessor, and the output of U7 is ignored. When the +5V supply is up, a reference voltage is set at U7 pin 2, the negative terminal. This reference voltage is one diode drop below the voltage at the positive terminal (pin 3). When power is lost, the voltage at the positive terminal falls below the reference voltage held by C3, and the output of U7 is immediately pulled low.

3-69. STATUS AND CONTROL

Tri-state buffers U11 and U40 read the three hardware fault-detector status signals, UNLVL, UNLOKL and RPTRPL, and the status of the REF INT/EXT switch. Control and buffer enable signals are latched by U17.

3-70. REAR SECTION, A3

The rear panel section consists of fuse/filter/line-voltage selector switch A3FL1, transformer A3T1, Power Supply PCA A3A1, fan A3B1, and IEEE-488 PCA A3A3A1. The line-selector switch accommodates two line voltages, 115/230 volts, selected by the orientation of a pullout PCB.

The transformer A3T1, with its two primary windings, accepts these two voltages and produces the necessary five secondary voltages. The Power Supply PCA A3A1 rectifies, filters, and regulates these secondary voltages to produce the dc voltages required by the Generator. The dc fan A3B1 is connected to the unregulated +5V supply.

3-71. Power Supply PCA, A3A1

The bridge rectifiers in the power supply are used in either a bridge or full-wave center-tapped configuration with capacitor input filters. Table 3-1 lists the rectifier configurations as well as the component designations for the various supplies.

The two +15V, the -15V, and the +5V supplies use conventional three-terminal IC regulators with internal current-limiting and temperature protection. All three 15V regulators have reverse voltage protection diodes CR3, CR4, and CR8.

The +37V regulator voltage is adjustable via R3. A 6.2V supply is developed from the +37V supply through resistor R4 and zener diode CR7 and is applied to the center tap of the 6V ac filament supply. This provides grid bias for the front panel displays. All regulators (except +37V) have their common reference terminals brought out to an external ground point on module A2 to reduce power supply ripple (P2).

Triac U6 is a voltage surge protector that protects against line voltage surges as well as overvoltage in case of a wrong setting of the selector switch.

Switch S1 is the REF INT/EXT reference selection switch and is not functionally part of the power supply.

3-72. IEEE-488 PCA, A3A3A1

The IEEE-488 Interface consists of the IEEE-488 printed circuit assembly (A3A3A1) mounted in a metal frame on the Generator rear panel. It interfaces directly with the Controller assembly A2A7.

The IEEE-488 Interface uses an NEC μ PD7210 Talker/Listener IC (U1) to handle all IEEE-488 standard communications protocol. All data, address, and control lines to the 7210 are buffered on the Controller. Two MC3447 bus drivers (U3 and U4) interface the 7210 directly to the IEEE-488 bus.

The presence of the IEEE-488 Interface is detected by the microprocessor when the board is plugged into the Controller board. The signal IEINL, normally at +5V, is pulled to circuit ground when the board is installed.

Tri-state buffer U6 provides the status of the IEEE-488 rear panel address switches when the Generator is interrogated. These switches determine the IEEE-488 bus address and talk-only (to) or listen-only (lo) modes. When opened, the switch just to the left of the IEEE-488 bus connector disconnects the bus shield ground from the system ground.

Table 3-1. Power Supply Rectifier Configuration

SUPPLY	RECT.	CONFIG.	CAP	REGULATOR	REMARKS
+37	CR6	Bridge	C11	A3A1 U4	Adjustable
+15	CR2	CT/FW	C2	" U5	Fixed
+15	CR2	CT/FW	C2	" U1	Fixed
-15	CR2	CT/FW	C5	" U2	Fixed
+5	CR5	CT/FW	C8	A3 U3	Fixed
+18	CR1	Bridge	C1		Unregulated relay supply
FIL	6V ac with center-tap biased at 6.2V dc.				

3-73. DEVIATION METER SECTION, A4

The deviation meter assembly (A4) consists of two circuit boards: the A/D PCA (A4A2) and the Discriminator PCA (A4A1) attached to a frame (A4A3). This assembly plugs into the Controller PCA (A2A7).

3-74. Discriminator PCA, A4A1

The RF input signal from front panel connector J3 is attenuated by 24 dB and high-pass filtered at 20 MHz before reaching the RF input of the mixer, U6. The generator supplies the local oscillator signal for the mixer. Under normal operation (generator mode) the generator RF signal is routed from the Attenuator/RPP (A2A5-J2) through A4A1-J1 to relay K1 and back to the front panel (A1-J1) RF OUTPUT. In the deviation meter mode, the generator RF signal is routed from the Attenuator through relay K1 to a 6-dB pad, then to the LO input of the mixer, U6. The relay is controlled by Q8 from the latch (U3-15) on the A/D board.

The IF output of the mixer, at 1.5 MHz, is amplified by Q9 (approximately 10 dB), filtered by C32, L7, C33 and limited by U5. When the discriminator is off, U5 is also turned off by Q8. The output of the limiter is again filtered by C1, C2, C3, L1, L2 and amplified by U1, an ECL line receiver. The output of U1 is coupled to the bases of the the current switching transistors Q3, Q4. The collectors of Q3, Q4 are clamped to one diode drop above ground in the positive direction by CR3, CR4 and one diode drop below the voltage on zener CR10 by CR1, CR2 in the negative direction. Q5, Q6 are constant current sources. The collectors of Q3, Q4 swing $10V + 2 V_{be}$. The current through C9, C10 is proportional to the voltage swing, capacitance and frequency. CR6-9 are current steering diodes.

Op amp U7A converts this current to a voltage which is proportional to frequency and hence deviation. Voltage zeroing loop, U7B, keeps the dc voltage at U7A pin 7 at zero volts and acts as a 20-Hz high-pass filter. This allows the IF frequency to vary up to ± 0.25 MHz without affecting performance. The dc voltage at the output of the voltage zeroing loop, U7B pin 1, is monitored by window detector U3A,B. If the dc voltage is outside the limits which represent approximately ± 0.25 MHz, a signal is sent back to the Controller. OFFSET R29 adjusts the dc voltage to zero and FM GAIN adjusts the full-scale deviation. This stage is also part of a 50 kHz Bessel low-pass filter. The next stage, U2A, is a selectable X10 amplifier. The X10 mode is the 50-kHz range. The range command from the latch (U3-6) is level shifted to +10V (on), -15V (off) by comparator U3C, and this controls the gate of Q1. The gain in the X10 mode (50 kHz Range) is adjusted by R3 (50 kHz GAIN). U2B is a selectable \pm unity gain amplifier which selects \pm Peak. When Q2 is on, - Peak is selected. U3C converts the TTL signal from the latch (A4A2 U3-9) to the voltage required by the FET. R32 (\pm PEAK) adjusts the gain balance. The remaining poles of the Bessel filter are determined by Z2, C52, C53 and U2C.

THEORY OF OPERATION

The audio voltage is high-passed by C23, R25. Comparator U4, in conjunction with C27, is a positive peak detector. Transistor Q7 resets the capacitor after the analog-to-digital converter takes a sample. U2D buffers the dc voltage.

3-75. A/D PCA, A4A2

The dc voltage from U2D is converted to a 10-bit word on the A/D PCA by U1, a successive-approximation A/D converter. This board provides power and digital control for the Discriminator PCA. U5 sends status bits back to the Controller.



static awareness



A Message From
John Fluke Mfg. Co., Inc.

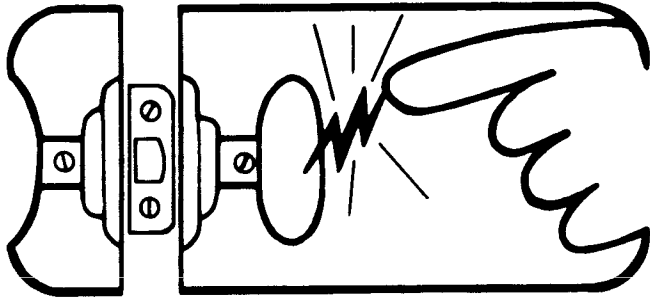

Some semiconductors and custom IC's can be damaged by electrostatic discharge during handling. This notice explains how you can minimize the chances of destroying such devices by:

1. Knowing that there is a problem.
2. Learning the guidelines for handling them.
3. Using the procedures, and packaging and bench techniques that are recommended.

The Static Sensitive (S.S.) devices are identified in the Fluke technical manual parts list with the symbol "⊗"

The following practices should be followed to minimize damage to S.S. devices.

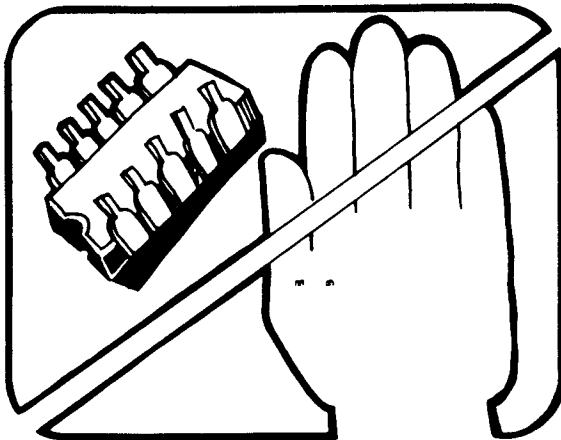

1. MINIMIZE HANDLING

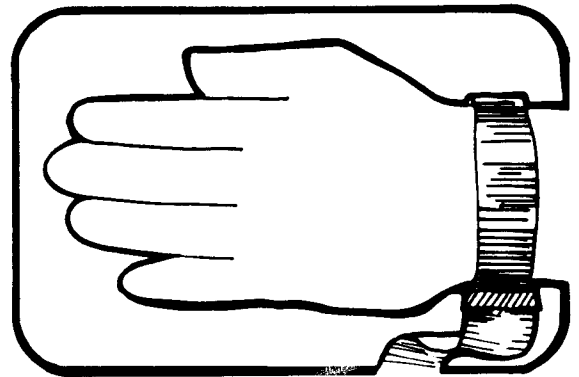

3. DISCHARGE PERSONAL STATIC BEFORE HANDLING DEVICES. USE A HIGH RESISTANCE GROUNDING WRIST STRAP.

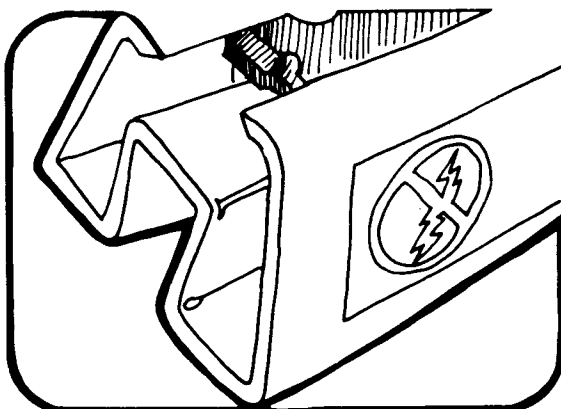

2. KEEP PARTS IN ORIGINAL CONTAINERS UNTIL READY FOR USE.

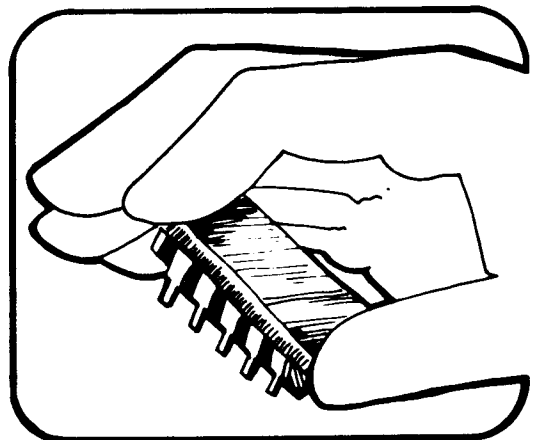

4. HANDLE S.S. DEVICES BY THE BODY

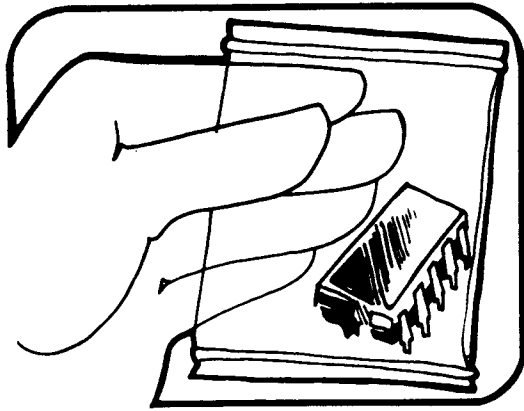

5. USE STATIC SHIELDING CONTAINERS FOR HANDLING AND TRANSPORT

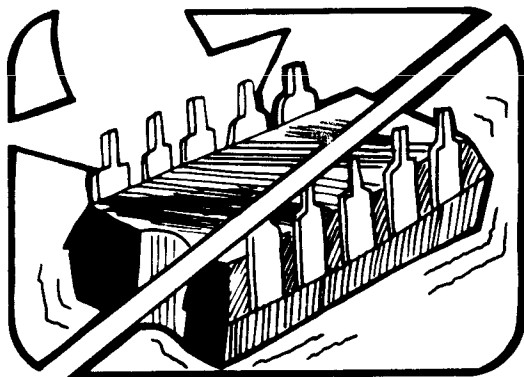

6. DO NOT SLIDE S.S. DEVICES OVER ANY SURFACE

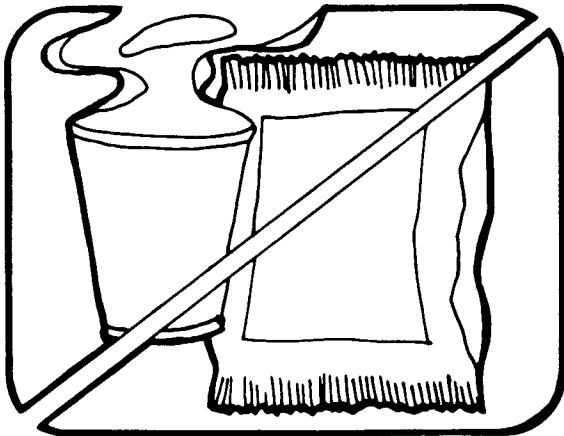

7. AVOID PLASTIC, VINYL AND STYROFOAM® IN WORK AREA

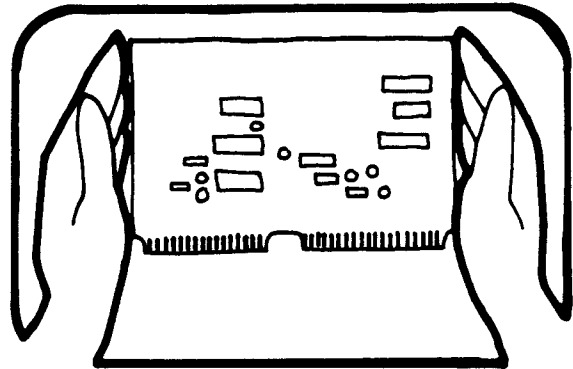

8. WHEN REMOVING PLUG-IN ASSEMBLIES, HANDLE ONLY BY NON-CONDUCTIVE EDGES AND NEVER TOUCH OPEN EDGE CONNECTOR EXCEPT AT STATIC-FREE WORK STATION. PLACING SHORTING STRIPS ON EDGE CONNECTOR HELPS TO PROTECT INSTALLED SS DEVICES.

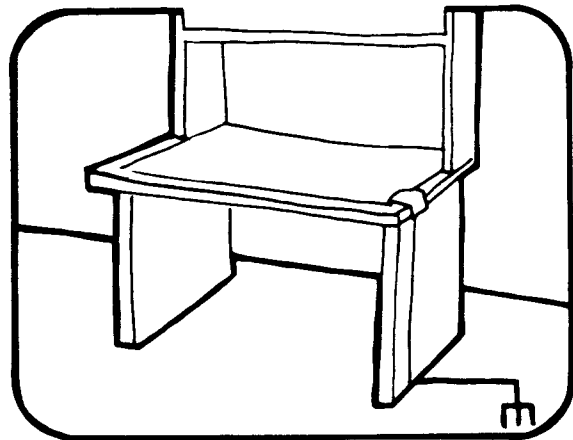

- 9. HANDLE S.S. DEVICES ONLY AT A STATIC-FREE WORK STATION
- 10. ONLY ANTI-STATIC TYPE SOLDER-SUCKERS SHOULD BE USED.
- 11. ONLY GROUNDED TIP SOLDERING IRONS SHOULD BE USED.

A complete line of static shielding bags and accessories is available from Fluke Parts Department, Telephone 800-526-4731 or write to:

JOHN FLUKE MFG. CO., INC.
PARTS DEPT. M/S 86
9028 EVERGREEN WAY
EVERETT, WA 98204

PORTIONS REPRINTED
WITH PERMISSION FROM TEKTRONIX, INC.
AND GENERAL DYNAMICS, POMONA DIV.

Section 4

Maintenance

4-1. INTRODUCTION

This section of the manual presents warranty information and service methods. Performance test procedures are presented in Section 4A, access procedures in 4B, calibration adjustment procedures in Section 4C, and troubleshooting and repair information in Section 4D.

Each Signal Generator is warranted for a period of one year following delivery to the original purchaser. The warranty is located in front of Section 1 of this manual.

4-2. SERVICE METHODS

The Signal Generator is designed to be easily and economically serviced. You may return your instrument to Fluke for service, or you may service it yourself, and repair it, if necessary, by module replacement or component replacement.

4-3. Fluke Service

Fluke Service is probably the easiest for you. To ship a Signal Generator to the Fluke Technical Service Center nearest you, see Section 2 for shipping requirements and Section 7 for a list of repair centers. A cost estimate will be provided if you request one and if your instrument purchase date is beyond the warranty period.

4-4. Module Replacement

If your Generator develops a problem, see the Troubleshooting Section 4D for information on identifying the faulty module. With a modest amount of technical knowledge and test equipment, you can identify the faulty module and replace it using the Module Exchange Program. This method takes only a day or two to restore the Generator to proper working order. Very little or no calibration is required depending on the module replaced.

Module exchange is used if it is necessary to completely recalibrate any of the three modules in your Generator that have an associated calibration EPROM.

4-5. Parts Replacement

Parts replacement requires more equipment and service capability but usually offers the best economy and quickest turnaround. It involves part replacement at the customer's facility.

Most faults are detected by the built-in self tests or the UNCAL status circuits. By noting the self-test error code and interrogating the UNCAL status code, the service technician learns where the problem is. By applying normal signal tracing and troubleshooting procedures (see Troubleshooting in Section 4D of the manual), the fault can be quickly identified.

MAINTENANCE

The faulty component is replaced, and then the instrument is recalibrated using Calibration Adjustments in Section 4C of this manual (if necessary). The Performance Tests explained in Section 4A of this manual are used to verify the Generator performance after repair or recalibration of the Generator.

Some assemblies have some non-field-replaceable parts. These parts, if replaced, would invalidate the calibration EPROM associated with that assembly. They are the Output (A2A4), the VCO (A2A2), and the Attenuator/RPP (A2A5) assemblies. Non-field-replaceable parts are listed in the appropriate parts lists at the bottom of that list.

In the event that a non-field-replaceable part is defective (about 10% of the parts are not field-replaceable), it is necessary for the module to be replaced using the Module Exchange Program in order to realize a complete recalibration of that module and its associated EPROM. Section 7 lists the national and international Sales Representatives and Service Centers.

Section 4A Performance Tests

4A-1. INTRODUCTION

Using the instrument specifications as the performance standard, the information in the following paragraphs describes the performance tests for the key parameters of the Signal Generator. These covers-on performance tests may be used as an acceptance test upon receipt of the instrument, as an indication that repair and/or calibration is required, or as a performance verification after completing repairs or calibration of the instrument. Individual performance tests can be used as troubleshooting aids.

The Signal Generator being tested (UUT) must be warmed up with all covers in place for at least 1 hour before starting the performance tests.

4A-2. TEST EQUIPMENT

Table 4A-1 gives a list of the recommended test equipment for the performance tests, adjustment procedures, and for troubleshooting the Generator. Figure 4A-1 shows a Two-Turn Loop.

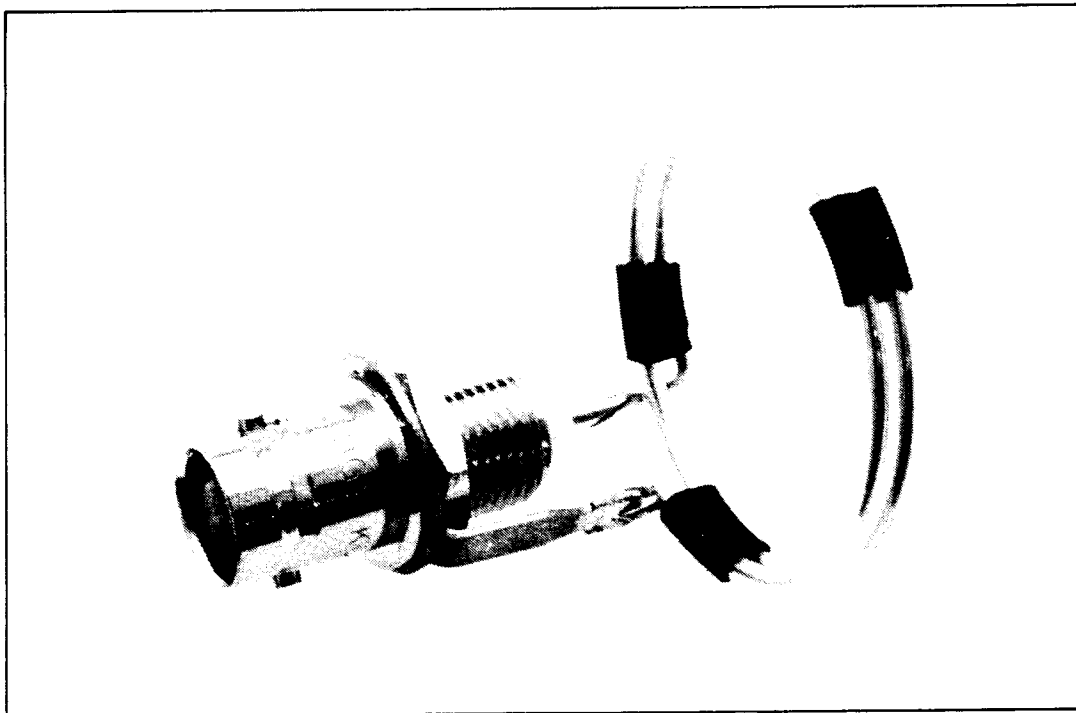

Figure 4A-1. Two-Turn Loop

**MAINTENANCE
PERFORMANCE TESTS**

Table 4A-1. Recommended Test Equipment

INSTRUMENT NAME	MINIMUM REQUIREMENT	MANUFACTURER DESIGNATION	NOTES (1)
DVM	5 1/2-Digit, 0.3% DC-20 kHz	JF 8840A-09	A,P
DMM	3 1/2-Digit, 1% DC and 1 kHz	JF 8020B	A,P,T
Wideband Amplifier	> 25-dB gain, 0.4 to 1050 MHz NF < 9 dB.	HP 8447D-010	P
RF-Spectrum Analyzer	0.01 to 1.5 GHz, 30-Hz BW	TEK 7L14/w Mainframe	P,T
Oscilloscope	Four-trace 300 MHz, 5 mV/Div	TEK 2465-11	T
FET Probe	DC-900 MHz	TEK 6201	T
RF Voltmeter	0.01 to 700 MHz, 0.01 to 3V +/- 10%	HI RF 801	T, 2
Frequency Counter	0.4-1050 MHz; 10 Hz res; 0.1V	JF 7220A	A,P,T
Modulation Analyzer	Input: 0.4 to 1050 MHz, 0 to +20 dBm AM: 10 to 90%, +/- 1%, FM: 0.1 to 100 kHz dev +/- 1%	HP 8901A	A,P,T,4
Distortion Analyzer	1 to 10% rng, +/-1dB, 0.4 and 1 kHz	HP 339B	A,P,T,4
Power Meter	Instrumentation accuracy < +/-1%	HP 435B	A,P,T,4
Sensor	-30 to 20 dBm; SWR < 1.2 for 0.4 to 1 MHz, < 1.1 for 1 to 1050 MHz	HP 8482A	4
Low-Level Sensor	-67 to -20 dBm; SWR < 1.4 for 10 to 30 MHz <1.15 for 30 to 1050 MHz	HP 8484A	4
SWR Bridge	10 MHz to 1000 MHz	Wiltron 62NF50	P
Attenuator, 60 dB	0.4 to 1050 MHz SWR <1.1	Narda 777C	P,5
Attenuator, 6 dB	0.5 to 1050 MHz SWR <1.1	Narda 777C	A,P,T
LF Synthesized Signal Generator	10 Hz to 11 MHz, 10 Hz steps, 1V pk, Spurs and Harm < -50dB	JF 6011A	A,P
HF Synthesized Signal Generator	10 kHz to 520 MHz, 10 Hz steps, 500 kHz FM	JF 6060A/AN	P
Frequency Standard	House Standard, 10 MHz		A,P
Test Cable	Dual pin to BNC	JF 732891	A,T
Adapter, Coax	50-ohm, Type-N(m) to BNC(f)	JF Y9308	A,P,T
Adapter, Service	50-ohm, Module output to SMA	JF 744177	T
Two-Turn Loop	For Leakage test (See Figure 4A-1.)	Homebuilt	P,T,3
Type-N Termination	50-ohm	JF Y9317	P
Coaxial Cable, 50 ohm	3 ft, BNC both ends	Y9111	A,P,T
Coaxial Cable, 50 ohm	6 ft, BNC both ends	Y9112	A,P,T

Table 4A-1. Recommended Test Equipment (cont)

INSTRUMENT NAME	MINIMUM REQUIREMENT	MANUFACTURER DESIGNATION	NOTES (1)
Screwdriver, electric	Set to 7 inch-pounds torque	Jergens-CL6500/CLT50	A, T
Power Supply, Variable	0 to 30V dc		T
<p>NOTES</p> <ol style="list-style-type: none"> 1. A = Adjustment; P = Performance Test; T = Troubleshooting. 2. Helper Instruments. 3. Two-Turn, 1-inch diameter loop made of #18 enamel wire soldered to a BNC connector. Figure 4A-1 shows a two-turn loop. 4. The HP8902A/11722A Measuring Receiver may be used in place of the wideband amplifier, 60-dB Attenuator, HP8901A, and the HP435B/8482A/8484A for the alternate performance test. 5. SWR verified and actual attenuation calibrated to +/- 0.2 dB by the operator at application frequencies. 			

4A-3. POWER-ON TEST

This performance test is the built-in self test that performs a simple functional check of the instrument.

REQUIREMENT

The Generator successfully passes the self test.

REMARKS

The test is begun each time the Signal Generator is turned on. Press any of the FUNCTION keys or the [CLR LCL] key to abort the test.

PROCEDURE

- a. Start the test with the POWER switch OFF.
- b. Turn the POWER switch ON.
- c. The Signal Generator automatically starts the self tests. The self tests include turning on all indicators and every segment of the display. This test takes five seconds.
- d. If the instrument fails any of the self tests, the results are shown in the four display fields. See the Self Test Description paragraph in Section 4D for the interpretation of the test failure codes.

If the Generator passes the self test, the instrument is programmed to the Instrument Preset state [RCL] [9][8].

The IEEE-488 Interface is programmed to local control.

4A-4. SYNTHESIS TEST

Using a Frequency Counter that operates on a common reference with the Generator, the Generator output frequency is measured at several programmed frequencies.

REQUIREMENT

The Generator's measured and programmed frequencies agree within \pm one count.

TEST EQUIPMENT

Frequency Counter

REMARKS

Failing this test indicates that the Synthesizer A2A1 assembly needs repair and/or recalibration.

PROCEDURE

- a. Connect the UUT 10 MHz IN/OUT to the Frequency Counter 10-MHz reference input, and connect the UUT RF OUTPUT to the Counter input.
- b. Set the UUT REF INT/EXT Switch to INT.
- c. Program the UUT to [RCL] [9][8].
- d. Program the UUT frequency to 100.00000 MHz.
- e. Program the UUT frequency step to 11.11111 MHz.
- f. As the frequency is stepped from 100.00000 MHz, 111.11111 MHz, etc., to 199.99999 MHz, verify that the Counter reading agrees with the UUT frequency \pm one count.
- g. Program the UUT frequency step to 100 MHz.
- h. As the frequency is stepped from 199.99999 to 499.99999 MHz, verify that the Counter reading agrees with the UUT frequency \pm one count.

4A-5. HIGH-LEVEL ACCURACY TEST

The output power is measured with a power meter at various frequencies. First, the step attenuator is set for zero attenuation, then each attenuator section is individually programmed, and the output level accuracy and attenuator section errors are computed.

TEST EQUIPMENT

Power Meter with a Sensor

REQUIREMENT

The output level accuracy, the attenuator section errors, and the sum of the attenuator section errors at each test frequency are less than \pm 2.5 dB.

REMARKS

Failing this performance test indicates that the Output (A2A4) and/or the Attenuator/RPP A2A5 assemblies need to be replaced. To determine which assembly is at fault, use Section 4D in this manual for Troubleshooting procedures.

The test frequencies of this procedure provide reasonable confidence in the amplitude accuracy of the UUT. However, additional test frequencies may be included in this test.

This test verifies the high-level accuracy of the Generator and also verifies that the amplitude correction factors for the individual Attenuator sections are correct. This test, in conjunction with the mid-level accuracy and low-level accuracy tests, verifies the overall level performance of the UUT.

PROCEDURE

- a. Calibrate and zero the Power Meter.
- b. Program the UUT to [RCL] [9][8].
- c. Connect the Power Sensor to the UUT RF OUTPUT.
- d. Program the UUT frequency to 0.4 MHz.
- e. Select each attenuator section by programming the UUT amplitude to the levels shown in Figure 4A-2, High-Level Accuracy Test Conditions. Record the measured power at each level.
- f. For each programmed level of Figure 4A-2, compute the output power error (subtract the programmed power in dBm from the measured power in dBm). These errors must not exceed ± 2.5 dB.
- g. For attenuator sections 1 through 7, subtract the measured power for section zero from the sum of the measured power for that section and the nominal attenuation for that section, e.g., $(-M0+M1+6)$ for section 1. The eight section errors and their sum must not exceed ± 2.5 dB.

Figure 4A-2 shows the parameters of the high-level accuracy test.

ATTENUATION		OUTPUT POWER				
		PROGRAM (dBm)	MEASURED (dBm)	ERROR (dB)	SECTION ERROR (dB)	LIMIT (dB)
SECTION	NOMINAL					
0	0	+12	M0	M0-12	M0-12	± 2.5 dB
1	6	+ 6	M1	M1-6	$-M0+M1+6$	"
2	12	0	M2	M2-0	$-M0+M2+12$	"
3	24	-12	M3	M3-12	$-M0+M3+24$	"
4	24	-12 [SPCL] [8][3]	M4	M4-12	$-M0+M4+24$	"
5	24	-12 [SPCL] [8][4]	M5	M5-12	$-M0+M5+24$	"
6	24	-12 [SPCL] [8][5]	M6	M6-12	$-M0+M6+24$	"
7	24	-12 [SPCL] [8][6]	M7	M7-12	$-M0+M7+24$	"
					Sum of Errors	± 2.5 dB

Figure 4A-2. High-Level Accuracy Test Conditions

NOTE

To test Attenuator sections 4 through 7, program the Signal Generator to -12 dBm, and key in [SPCL][8][3] through [8][6], respectively.

- h. Repeat steps d through g with the UUT programmed to each of the following frequencies:

120, 244, 245, 350, and 520 MHz.

To illustrate the procedure, Figure 4A-3 shows the measured power and the error calculations. This example is for one frequency, and these measurements and calculations are repeated at other frequencies. In this case, the section errors and the sum of the section errors are within the test limits. Therefore, the unit passes.

4A-6. MID-LEVEL ACCURACY TEST

The level accuracy is verified, from -24 to -66 dBm at frequencies of 120, 244, 245, 350, and 520 MHz, using the Power Meter with a Low-Level Sensor.

REQUIREMENT

Amplitude accuracy is ± 2.5 dB from +13 to -127dBm.

TEST EQUIPMENT

Power Meter with a Low-Level Sensor

REMARKS

This test, in conjunction with the High-Level Accuracy Test and the Low-Level Accuracy Test, verifies the overall level performance of the UUT.

It is convenient to use the UUT RF ON/OFF control when zeroing the Power Meter.

ATTENUATION		OUTPUT POWER		ERROR (dB)	SECTION ERROR (dB)	LIMIT (dB)
		PROGRAM (dBm)	MEASURED (dBm)			
SECTION	NOMINAL					
0	0	+12	+12.2	+0.2	+12.2-12.0	= +0.2
1	6	+ 6	+05.9	-0.1	-12.2+5.9+6	= +0.3
2	12	0	-00.2	-0.2	-12.2-0.2+12	= -0.4
3	24	-12	-12.1	-0.1	-12.2-12.1+24	= -0.3
4	24	-12 [SPCL][8][3]	-11.8	+0.2	-12.2-11.8+24	= +0.0
5	24	-12 [SPCL][8][4]	-12.0	+0.0	-12.2-12.0+24	= -0.2
6	24	-12 [SPCL][8][5]	-12.3	-0.3	-12.2-12.3+24	= -0.5
7	24	-12 [SPCL][8][6]	-11.9	+0.1	-12.2-11.9+24	= -0.1
					Sum of Errors	= -1.0

Figure 4A-3. High-Level Accuracy Test Conditions

PROCEDURE

- a. Program the UUT to the Instrument Preset State [RCL] [9][8], and then program 30 MHz and -24 dBm.
- b. Calibrate the Power Meter.
- c. Connect the Power Meter with a Low-Level Sensor to the UUT RF OUTPUT.
- d. Zero the Power Meter.
- e. With the Power Meter, measure the UUT output power (in dBm). It should agree with the programmed level within ± 2.5 dB.
- f. Repeat step e for levels of -30, -36, -42, -48, -54, -60, and -66 dBm.
- g. Repeat steps d to f for frequencies of 244, 245, 350, and 520 MHz.

4A-7. LOW-LEVEL ACCURACY TEST

The Power Meter with a Low-Level Sensor and the calibrated 60-dB Attenuator are used to verify the UUT level accuracy at -127 dBm and at frequencies of 120, 244, 245, 350, and 520 MHz, by using the Spectrum Analyzer as an indicator.

REQUIREMENT

Amplitude accuracy is ± 2.5 dB from +13 to -127 dBm.

TEST EQUIPMENT

Wideband Amplifier
60-dB Attenuator
RF Spectrum Analyzer
Power Meter with a Low-Level Sensor

REMARKS

This test, in conjunction with the Mid-Level and High-Level Accuracy Tests, verifies the overall level performance of the UUT.

Failing this test, but passing the High-Level Accuracy Test, probably indicates a leak-around problem in the UUT Attenuator. Service tip:

- Check for a broken feed-through filter or improper mechanical assembly, i.e., loose screws and/or damaged or misplaced gaskets.
- It is convenient to use the UUT RF ON/OFF control when zeroing the Power Meter.

PROCEDURE

- a. Program the UUT to the Instrument Preset State [RCL] [9][8], then program 30 MHz and -67 dBm.
- b. Calibrate and then connect the Power Meter with a Low-Level Sensor to the UUT RF OUTPUT.

**MAINTENANCE
PERFORMANCE TESTS**

- c. Program the UUT to -67 dBm.
- d. Zero the Power Meter.
- e. With the Power Meter, measure the UUT output power (in dBm) and record the measurement as the variable P.
- f. Connect UUT RF OUTPUT through the 60-dB Attenuator and the Wideband Amplifier to the input of the RF Spectrum Analyzer. Use well shielded cables to avoid leakage that could affect the measurement.
- g. Adjust the Analyzer to display the signal, using a resolution bandwidth of 1 kHz and a vertical display of 1 dB/Div. Adjust the reference level so that the response is at a convenient reference point on the display, e.g., 2 dB below top scale. This signal response corresponds to a level of (P-A) dBm, where A is the value of the 60-dB Attenuator.
- h. Program the UUT to a level of -127 dBm, remove the 60-dB Attenuator, and note the difference in the resulting response on the Spectrum Analyzer from the previous response (P-A). The actual UUT output level is (P-A) plus this difference and should agree with the programmed level to within ± 2.5 dB.
- i. Repeat steps c through h for frequencies of 244, 245, 350, and 520 MHz.

4A-8. ALTERNATE-LEVEL ACCURACY TEST

The Measuring Receiver is used to verify the UUT level accuracy from +11 dBm to -127 dBm, and at various amplitude and frequency settings that test all level ranges of the UUT on all RF bands.

REQUIREMENTS

Amplitude accuracy is ± 2.5 dB from +13 dBm to -127 dBm.

REMARKS

This one test is a more comprehensive test than the High-Level, Mid-Level, and Low-Level Accuracy tests.

Failing this test at levels above approximately -50 dBm indicates that the A2A4 Output and/or A2A5 Attenuator/RPP needs to be replaced.

Failing this test at lower levels probably indicates a leak-around problem with the Attenuator. Check for loose connectors, loose screws, improper gasketing, or a broken feed-through filter.

It is convenient to use the UUT RF ON/OFF control when zeroing the power meter function of the Measuring Receiver.

TEST EQUIPMENT

Measuring Receiver

PROCEDURE

- a. Connect the UUT 10 MHz-OUT to the 10-MHz timebase input of the Measuring Receiver.
- b. Set the UUT REF INT/EXT switch to INT.
- c. Program the UUT to [RCL] [9][8], then program the UUT to 0.4 MHz, +11 dBm and program the Amplitude Step to 6 dB.
- d. Calibrate the Measuring Receiver and connect it to the UUT RF OUTPUT.
- e. Verify that the level measured with the Measuring Receiver agrees with the UUT programmed level to within ± 2.5 dB, as the UUT level is stepped down from +11 dBm to -127 dBm in six dB steps at each of the following frequencies:

2.5, 120, 244, 245, 350, and 520 MHz.

4A-9. OUTPUT LEAKAGE TEST

The output signal leakage is verified with a two-turn loop by measuring the induced signal with a spectrum analyzer and comparing it to a $1 \mu\text{V}$ reference established at each frequency from the UUT.

REQUIREMENT

The radiated emissions induce less than $1 \mu\text{V}$ of the Generator's output signal into a 1-inch diameter, two-turn loop, 1 inch away from any surface of the Generator as measured into a 50-ohm receiver.

TEST EQUIPMENT

Wideband Amplifier

RF Spectrum Analyzer

Two-Turn Loop

Type-N Termination

A screen room may be required, depending on the RF environment.

REMARKS

Failing this test probably indicates a broken feed-through filter or improper mechanical assembly (i.e., loose screws and/or damaged or misplaced gaskets).

PROCEDURE

- a. Connect the UUT RF OUTPUT to the Wideband Amplifier input, and connect the Amplifier output to the Spectrum Analyzer input. Use well shielded cables to avoid leakage that could affect the measurement.
- b. Program the UUT to the Instrument Preset State, [RCL] [9][8].
- c. Program the UUT to -107 dBm.
- d. Adjust the Spectrum Analyzer to display the UUT signal for a convenient reference, using a vertical scale of 10 dB/division, a resolution bandwidth of 3 kHz, and a span/division of 5 kHz/division.

**MAINTENANCE
PERFORMANCE TESTS**

- e. Disconnect the Amplifier from the UUT and terminate UUT OUTPUT with type-N Termination.
- f. Connect the two-turn loop to the Amplifier input.
- g. Program the UUT to +13 dBm.
- h. Verify that the leakage is less than -107dBm (1 μ V), as indicated by the Spectrum Analyzer by moving the two-turn loop over the UUT surface at a distance of 1 inch.
- i. Repeat steps c through h at 50, 150, 250, 375, and 520 MHz.

4A-10. ALTERNATE OUTPUT LEAKAGE TEST

RF leakage is verified by measuring the induced signal in a two-turn loop with the Measuring Receiver.

REQUIREMENTS

The output signal leakage must induce less than 1 μ V into a 1-inch diameter two-turn loop, 1 inch away from any surface of the Generator as measured into a 50-ohm receiver.

REMARKS

This test is an alternative to the Output Leakage test.

Failing this test indicates a problem feed-through filter or improper mechanical assembly (i.e., loose screws, and/or damaged or misplaced gaskets).

The Measuring Receiver is used to measure the UUT leakage relative to a 1 μ V reference established at each frequency.

TEST EQUIPMENT

Measuring Receiver
Two-Turn Loop
Type-N Termination

A screen room may be required, depending on the RF environment.

PROCEDURE

- a. Connect the UUT 10-MHz OUT to the 10-MHz timebase input of the Measuring Receiver.
- b. Set the UUT REF INT/EXT switch to INT.
- c. Program the UUT to the Instrument Preset State, [RCL] [9][8].
- d. Program the UUT to -107 dBm.
- e. Connect the Measuring Receiver sensor to the UUT RF OUTPUT.
- f. Set the Measuring Receiver to make relative level measurements to the -107 dBm signal applied.

- g. Disconnect the sensor from the UUT, and terminate the UUT RF OUTPUT with the Type-N Termination.
- h. Connect the two-turn loop to the Measuring Receiver sensor.
- i. Program the UUT to +13 dBm.
- j. Verify the instrument leakage is less than -107 dBm (1 μ V) as indicated by the Measuring Receiver, by moving the Two-Turn Loop over the UUT surface at a distance of one inch from the UUT.
- k. Repeat steps d through j at 50 MHz, 50 MHz, and 520 MHz.

4A-11. SWR TESTS

These tests use a VSWR bridge and a Spectrum Analyzer to verify SWR of the UUT.

REQUIREMENTS

The output VSWR is less than 1.3:1 for output levels <-10 dBm.

TEST EQUIPMENT REQUIRED

SWR bridge (Wiltron 62N50 or equivalent)
High-Frequency Spectrum Analyzer
HFSSG (Fluke 6060A/AN or equivalent)

REMARKS

The UUT settings in this procedure are chosen to provide confidence in the SWR performance of the UUT throughout its range. However, performance also may be checked at other levels <-10 dBm.

PROCEDURE

- a. Connect the HFSSG to the VSWR Bridge RF IN.
- b. Connect the Spectrum Analyzer to the VSWR Bridge RF OUT.
- c. Connect the UUT to the VSWR Device Under Test.
- d. Program UUT to 1 MHz, -10 dBm.
- e. Program the HFSSG to 10 MHz, 13 dBm.
- f. Set the Spectrum Analyzer controls to display approximately 10 to 520 MHz. Set Reference Level to 0 dBm.
- g. Step HFSSG from 10 MHz to 520 MHz in 5 MHz-steps and note frequency and level where the level is a maximum.
- h. Program HFSSG to the frequency found in step g.
- i. Disconnect UUT from VSWR bridge.

- j. Note Spectrum Analyzer level.
- k. The difference between the levels in steps i and g should be greater than 18 dB.

4A-12. HARMONIC AND SPURIOUS TEST

Using a Spectrum Analyzer, the level of the harmonic and spurious signals is compared to the desired signal at various programmed frequencies.

REQUIREMENTS

RF harmonics < -30 dBc for RF frequencies > 10 MHz, < -26 dBc for RF frequencies < 10 MHz; spurious (non-harmonic) < -35 dBc.

TEST EQUIPMENT

RF Spectrum Analyzer

PROCEDURE

- a. Connect the UUT RF OUTPUT to the Spectrum Analyzer input.
- b. Program the UUT to [RCL] [9][8]. Then program the Generator to +13 dBm.
- c. Program the UUT to 0.01 MHz.
- d. Set the Spectrum Analyzer controls to display the UUT output signal and its harmonics (at least three harmonics wherever possible). Be careful not to overload the Analyzer input. Overloading the Analyzer causes it to generate harmonics, thus invalidating the test.
- e. Verify that all the harmonics are more than 26 dB below the fundamental signal.
- f. Repeat step c for UUT frequencies of 50 MHz, 240 MHz, 300 MHz and, 520 MHz. Verify that all the harmonics are more than 30 dB below the fundamental signal.
- g. Program the UUT to 185 MHz.
- h. Verify the spur at 245 MHz is < -35 dBc.
- i. Program the UUT to 244 MHz.
- j. Verify the spur at 312 MHz is < -35 dBc.
- k. Program the UUT to 244.99 MHz, 0 dBm.
- l. Set the Spectrum Analyzer controls for the appropriate reference level, center frequency, span, and resolution to display the UUT signal and spur frequencies with appropriate noise floor and signal resolution for the following steps.
 - 1. Verify the spurs at the offsets of 10 kHz, 15 kHz, and 20 kHz are < -35 dBc.
 - 2. Verify the spurs at the offsets of 0.2 MHz and 10 MHz are < -35 dBc.
 - 3. Verify the spurs at 60, 120, 180 Hz are < -35 dBc.

4. Program the UUT level to 1 dBm.
5. Verify the spurs at 10 MHz, 20 MHz, and 30, 40, 80, 120, 200 MHz are < -35 dBc.
6. Verify the spurs at 800 MHz and 1044.99 MHz are < -35 dBc.

4A-13. MODULATION TESTS

These tests use the Modulation Analyzer to verify modulation accuracy and residual and incidental modulation of the UUT. The modulation distortion is verified by measuring the demodulated output of the Modulation Analyzer with a Distortion Analyzer. The internal modulation oscillator frequency is measured using the Frequency Counter on the demodulated output of the Modulation Analyzer. Table 4A-2 lists the requirements for the modulation tests.

REMARKS

Failing this performance test indicates that the associated circuitry needs repair and/or recalibration.

Where residual noise affects the accuracy of the measurements by the Modulation Analyzer, apply correction methods provided by the Modulation Analyzer manufacturer.

The UUT settings in this procedure are chosen to provide confidence in the modulation performance of the UUT throughout its range. However, performance also may be checked at other instrument settings, if desired.

The FM deviation accuracy depends upon software correction data stored in the VCO Calibration EPROM that is derived from the measured data of the particular VCO assembly installed in the Generator.

Table 4A-2. Modulation Tests Requirements

REQUIREMENTS PARAMETER	SPECIFICATION
MOD FREQ	< +/- 5% at 0.4 or 1 kHz
AM ACCURACY	Display accurate to within +/-6% for internal rates and depths of 99% or less, and peak amplitudes of +13 dbm or less.
AM DISTORTION	< 5% THD for 50% AM at 1-kHz rate.
RESIDUAL AM	< 0.1% rms (-60dBc) in a 0.05-kHz to 15-kHz bandwidth.
FM ACCURACY	< +/- 5% for 1 kHz-rate and > 1 kHz deviation.
RESIDUAL FM	< 200 Hz peak in a 0.05 kHz to 15 kHz band.

TEST EQUIPMENT

Modulation Analyzer
Distortion Analyzer
Frequency Counter
Low-Frequency Synthesized Signal Generator (LFSSG)
DVM

PROCEDURE

1. Internal Modulation Oscillator Frequency Test
 - a. Connect the UUT RF OUTPUT to the Modulation Analyzer input.
 - b. Connect the Modulation Analyzer modulation output to the Frequency Counter input.
 - c. Program the Modulation Analyzer to measure AM depth in a 0.05-kHz to 15-kHz bandwidth.
 - d. Program the UUT to [RCL][9][8]. Program the UUT for 90% INT AM at a 1-kHz rate and a level of +1 dBm.
 - e. Verify that the Counter reads between 950 and 1.050 kHz.
 - f. Program the UUT to a modulation frequency of 400 Hz.
 - g. Verify that the Counter reads between 380 Hz and 420 Hz.
2. Internal AM Accuracy Test
 - a. Measure the mean AM depth, $(+PEAK \text{ plus } -PEAK)/2$, with the Modulation Analyzer.
 - b. Verify that the mean AM depth is between 84% and 96%.
 - c. Program the UUT to a modulation frequency of 1 kHz.
 - d. Verify that the mean AM depth is between 84% and 96%.
3. AM Accuracy and Distortion Test
 - a. Connect the output of the LFSSG to the UUT MOD INPUT and the DVM (use a BNC T connector).
 - b. Program the UUT for a frequency of 0.4 MHz, 1 dBm level, and EXT AM at 50% AM depth.

- c. Program the LFSSG for 1 kHz at 0.7071V rms as measured by the DVM.
- d. Connect the modulation output of the Modulation Analyzer to the input of the Distortion Analyzer.
- e. Set the Distortion Analyzer to measure the THD of the 1-kHz modulation signal.
- f. Verify that the mean AM depth (+PEAK plus -PEAK)/2, is between 44.0% and 56.0%.
- g. Verify that the THD is less than 5%.

Table 4A-3. AM Test Conditions

FREQUENCY (MHz)	LEVEL (dBm)	AM (%)
0.4	1	30
		70
		90
244.9	7	30
		70
		90
245	1	50
		90
		50
350	7	50
		90
		50
520	1	50
		90
		50
	7	50
		90
		90

Table 4A-4. AM Depth Range

PROGRAMMED DEPTH (%)	MEAN AM DEPTH(%)		MAXIMUM THD(%)
	MIN.	MAX.	
30	24	36	-
50	44	56	5
90	84	96	-

**MAINTENANCE
PERFORMANCE TESTS**

- h. Program the remaining combinations of RF frequency, level, and AM depth listed in Table 4A-3. For each combination, verify that the mean AM depth is between the allowed limits and that the THD is less than the allowed limit. The allowed limit depends on programmed depth, as shown in Table 4A-4.
 - i. Disconnect the LFSSG from the UUT.
4. Residual AM Test
- a. Program the UUT to 100 MHz, +7 dBm, and no modulation.
 - b. Program the Modulation Analyzer to measure rms (or average) AM in a 0.05-kHz to 15-kHz bandwidth.
 - c. Verify that the residual AM is less than 0.1% rms (or 0.09% average).
5. FM Accuracy
- a. Connect the output of the LFSSG to the UUT MOD INPUT connector and the DVM (use a BNC T connector).
 - b. Program the Modulation Analyzer to measure peak FM in a 0.3-kHz to 3-kHz bandwidth.
 - c. Program the UUT frequency to 245 MHz, 7 dBm, 99.9 kHz deviation, and EXT FM.
 - d. Set the LFSSG to 1.0 kHz and adjust its level so the DVM reads 707.1 mV rms.
 - e. Verify that the Modulation Analyzer reading is between 95 kHz and 105 kHz, as the UUT frequency is stepped up to 520 MHz in 25-MHz steps. (Tip: use the instrument FREQ STEP feature.)
 - f. Program the UUT to 9.99-kHz deviation.
 - g. Verify that the Modulation Analyzer reading is between 9.5 kHz and 10.5 kHz.
 - h. Program the UUT to 400-kHz deviation.
 - i. Verify that the Modulation Analyzer reading is between 380 and 420 kHz. Note: The recommended Modulation Analyzer will indicate an error at exactly 420-kHz deviation, or greater.

- j. Disconnect the LFSSG from the UUT.

NOTE

It may be necessary to compensate for residual noise effects using the procedure presented in the Modulation Analyzer manual.

6. Residual FM Test

- a. Program the UUT for a frequency of 4 MHz and no modulation.
- b. Program the Modulation Analyzer to measure peak FM in a 0.05-kHz to 15-kHz bandwidth.
- c. Verify that the Modulation Analyzer reading is less than 200-Hz peak at the following UUT frequencies:

10, 50, 100, 200, 244, 250, 385, 450, and 520 MHz

4A-14. DEVIATION METER TEST

A RF signal generator is frequency modulated and checked with a modulation analyzer. These readings are compared with the deviation readings from the UUT.

REQUIREMENT

The accuracy is better than $\pm 6\%$ of full-scale range for rates between 100 Hz and 8 kHz. The minimum sensitivity is greater than 15 mV rms over the frequency range of 30 to 500 MHz.

TEST EQUIPMENT

Low-Frequency Synthesized Signal Generator (LFSSG)
High-Frequency Synthesized Signal Generator (HFSSG - 6060A/AN or equivalent)
Modulation Analyzer

PROCEDURE

1. Connect the output of the LFSSG to the HFSSG MOD INPUT connector.
2. Connect the HFSSG RF OUTPUT to the Modulation Analyzer input (use a 6 dB pad at the Modulation Analyzer RF input) and the UUT DEVIATION METER INPUT.
3. Connect the HFSSG REF OUT to the UUT REF IN. Set UUT to EXT REF.
4. Program the HFSSG frequency to 500 MHz, 7 dBm, 400-kHz deviation, and EXT FM.

**MAINTENANCE
PERFORMANCE TESTS**

5. Program the LFSSG to 1 kHz, 383 mV rms TERM.
6. Program the Modulation Analyzer to measure + peak FM in a 0.02-kHz to > 20-kHz bandwidth.
7. Program the UUT for Meter Mode ([SPCL][6][1]) and program the Frequency to 500 MHz. UUT should be in 500-kHz range, + Peak.
8. Note the deviation readings in both + and - peak modes on the Modulation Analyzer and on the UUT. They should be within ± 30 kHz of each other.
9. Repeat step 7 for LFSSG set to 0.1 kHz and 8 kHz.
10. Program LFSSG to 1 kHz. Adjust the level so that the Modulation Analyzer reads 400-kHz deviation in + peak. Set UUT to + PEAK.
11. Program the HFSSG to 500-kHz deviation. (The Modulation Analyzer will indicate an error.) UUT should read between 470 and "OL" kHz. If the UUT reads "OL" adjust FM deviation on HFSSG so that the UUT reads 500 kHz. HFSSG FM deviation should be greater than 470 kHz.
12. Program the HFSSG to 40-kHz Deviation. Set the UUT to the 50-kHz range by pressing "500/50 KHZ RANGES" [400/1000].
13. Program LFSSG to 0.1, 1, 8 kHz and note deviation readings in both + and - peak modes on the Modulation Analyzer and the UUT. The readings should be within ± 3 kHz of each other.
14. Program the LFSSG to 1 kHz and note the Modulation Analyzer reading in + Peak.
15. Disconnect the Modulation Analyzer and 6 dB pad.
16. Program the HFSSG Amplitude to 15 mV rms. The UUT reading in + PEAK should be within ± 3 kHz of the reading in step 14.
17. Reconnect the Modulation Analyzer to the HFSSG RF Output. (The UUT DEVIATION METER INPUT should still be connected.)
18. Program the HFSSG and UUT to 30 MHz, 7 dBm. Note the Modulation Analyzer reading in + Peak.
19. Disconnect the Modulation Analyzer.
20. Program the HFSSG to 15 mV rms. The reading should be within ± 3 kHz of the reading in step 17.

Section 4B

Access Procedures

4B-1. INTRODUCTION

The information in this section describes the general access procedures for the following major module assemblies.

- Front Section Assembly, A1
- Rear Section Assembly, A3
- Meter Module Assembly, A4
- Synthesizer Board, A2A1
- Controller Board, A2A7
- Output Board, A2A4
- Attenuator/ RPP Assembly, A2A5.
- VCO Board, A2A2

Access to other assemblies is straightforward; therefore, other assemblies are not detailed in this manual.

4B-2. LOCATION OF MAJOR ASSEMBLIES

The location of the major assemblies of the Signal Generator is illustrated in Section 8.

Information on exchanging modules is presented in Section 4D.

4B-3. ACCESS INSTRUCTIONS

Access instructions for each module of the Signal Generator are provided in the following paragraphs. Before performing any disassembly of the Signal Generator, remove the power cord from the rear panel power receptacle and remove the exterior top and bottom instrument covers.

To install the assemblies, reverse the disassembly steps. Be certain the pin connectors and filter sockets are straight when replacing the boards and that the PCA pulls are not pinched between the module and the module cover.

4B-4. Removing the Front Section Assembly, A1

1. Disconnect the MOD INPUT wire W1 at the module connector located at the front of the Attenuator module.
2. Disconnect the front panel display ribbon cable at the controller.
3. Disconnect the two SMA connectors and one SMB connector from the meter module assembly.

4. Remove the SMA connector at the Attenuator/RPP assembly.
5. Remove the two screws that hold the RF OUTPUT connector to the module.
6. Remove the decals from both front panel handles. Removing the decals ruins them; new decals should be installed to maintain a proper instrument appearance. The part number for the decal is listed in Section 5.
7. Remove the five flathead screws from each front panel handle.

4B-5. Removing the Rear Section Assembly, A3

1. Disconnect the Synthesizer, Controller, and Attenuator power cable at the power supply.
2. Remove the IEEE-488 Interface assembly from the back of the instrument rear panel.
3. Remove the inside part of the 10-MHz IN/OUT BNC connector.
4. Remove the decals for both rear panel handles. Removing the decals ruins them; replace them with new decals to maintain a proper instrument appearance. The part number for the decal is listed in Section 5.
5. Remove the five flathead screws from each handle and pull the rear panel assembly out from the Signal Generator.
6. If you need to completely detach the rear panel assembly from the Generator, unfasten the front panel power switch.

4B-6. Removing the Synthesizer Board, A2A1

1. Remove the number 6 screws holding the top module (A2) cover. (The number 10 screws are adjustment-access screws and need not be removed.) Remove the module cover.
2. Remove the number 6 screws holding the board, and then carefully remove the board.

4B-7. Removing the Output Board, A2A4

1. Remove the number 6 screws holding the bottom module (A1) cover. (The number 10 screws are adjustment-access screws and need not be removed.) Remove the module cover.
2. Remove the plug-in coupling capacitor between the Output and the VCO boards.
3. Remove the number 6 screws holding the board, and then carefully remove the board.

4B-8. Removing the Attenuator/RPP A2A5 Assembly

1. Disconnect the SMA connector at the Attenuator that leads to the Meter Module Assembly.

2. Disconnect the control harness from the Relay Driver PCA.
3. Remove the number 6 screws holding the assembly to the main module. Note: It is not necessary to remove the screws holding the Relay Driver PCA.

4B-9. Removing the VCO Board, A2A1

1. Remove the number 6 screws holding the bottom module (A2) cover. (The number 10 screws are adjustment-access screws and need not be removed.) Remove the cover.
2. Remove the plug-in capacitor that couples the Output board to the VCO.
3. Remove the number 6 screws holding the board, and remove the board. The screws with the washers must be placed next to the varactors.

4B-10. Removing the Controller Board, A2A7

1. Remove the Meter Module Assembly (A4) as described in 4B-12.
2. Remove the connectors attached to the display, Attenuator, and power supply.
3. Remove the IEEE assembly.
4. Remove the number 6 screws holding the board, and remove the board.

4B-11. Removing the Meter Module Assembly, A4

1. Remove the 2 SMA and 1 SMB connectors on the Meter Module Assembly.
2. Remove the four number 6 screws holding the Meter Module Assembly to the main module. Note: It is not necessary to remove the Meter Module (A4) cover.
3. Remove the three number 6 screws holding the A/D PCA (A4A2) to the main module.
4. Pull the assembly straight up, being careful not to damage the connector. (Set the assembly aside, if the controller is to be removed).

4B-12. Removing the Discriminator Board, A4A1

1. Remove the Meter Module Assembly, A4, as described in 4B-12.
2. Remove the nuts holding the 2 SMA and SMB connectors to the meter module.
3. Remove the number 6 screws holding the Meter Module cover. (The number 10 screws are adjustment-access screws and need not be removed).
4. Remove the number 6 screws holding the board, and remove the board.

4B-13. Removing the A/D Board, A4A2

1. Remove the Meter Module Assembly as described in 4B-12.
2. Remove the number 6 screws holding the board, and remove the board.

Section 4C

Calibration Adjustments

4C-1. INTRODUCTION

The adjustment procedures for the Generator are described in the following paragraphs. The recommended test equipment for calibration is denoted by an A in Table 4A-1.

Adjustment procedures for the Power Supply, Display, Output, Synthesizer, Deviation Meter and Attenuator/RPP assemblies are covered in this section.

4C-2. SAFETY

This is a Safety Class I instrument. It is provided with a protective earth terminal. Warnings and cautions are for your protection and for avoiding damage to the equipment. Please take them seriously.

WARNING

BECAUSE SOME SERVICE PROCEDURES DESCRIBED HERE ARE DONE WITH POWER APPLIED TO THE SIGNAL GENERATOR AND WITH PROTECTIVE COVERS REMOVED, SERVICE SHOULD BE DONE ONLY BY TRAINED SERVICE PERSONNEL WHO UNDERSTAND THE HAZARDS INVOLVED. WHERE SERVICE CAN BE PERFORMED WITHOUT POWER APPLIED, THE SIGNAL GENERATOR SHOULD BE UNPLUGGED FROM THE LINE POWER.

DO NOT INTERRUPT THE PROTECTIVE GROUNDING CONNECTION. TO DO SO WOULD CREATE A POTENTIAL SHOCK HAZARD THAT COULD RESULT IN PERSONAL INJURY. SECURE THE INSTRUMENT AGAINST UNINTENDED OPERATION IF IT IS LIKELY THAT THIS PROTECTION HAS BEEN IMPAIRED. USE ONLY 250V FUSES OF THE PROPER CURRENT RATING.

CAUTION

To avoid damage to the Generator, unplug the instrument before removing any Printed Circuit Assembly.

4C-3. POWER SUPPLY, A3A1, ADJUSTMENT

This procedure covers the +37V adjustment, R3, on the Power Supply assembly, A3A1. This is the only adjustment on the Power Supply PCB.

TEST EQUIPMENT

DMM

REMARKS

This adjustment is accessible through a hole in the bottom lip of the rear panel.

See Figure 4C-1 for the location of the power supply test points.

PROCEDURE

R3 is adjusted for +37V as measured at TP5.

1. Remove the UUT top and bottom instrument covers. Connect the DMM to TP5 with the ground lead (black wire) connected to the power distribution connection point on the module plate.
2. Program the UUT to [RCL] [9][8].
3. Adjust R3 for a DMM reading of $+37.00 \pm 0.05V$.
4. Verify the other supply voltages at the test points listed in the following:

TP	Voltage Limits
11	14.5 to 15.7
3	14.5 to 15.7
2	-14.5 to -15.7
4	4.85 to 5.20
1	17.4 to 22.6

NOTE

The voltage at TP1 depends on the line voltage. The limits shown are for a line voltage exactly equal to the line voltage selector setting, i.e., 115 or 230V ac.

5. Remove the test leads, and reinstall the top and bottom instrument covers.

4C-4. DISPLAY ASSEMBLY, A1A1, ADJUSTMENT PROCEDURE

This procedure covers the adjustment of R16, the external modulation level indicator.

TEST EQUIPMENT

DVM

REMARKS

This adjustment is independent of other adjustments and assumes proper circuit operation.

Adjustment R16 is located below TP1 on the rear of the Display PCA, just above the POWER switch.

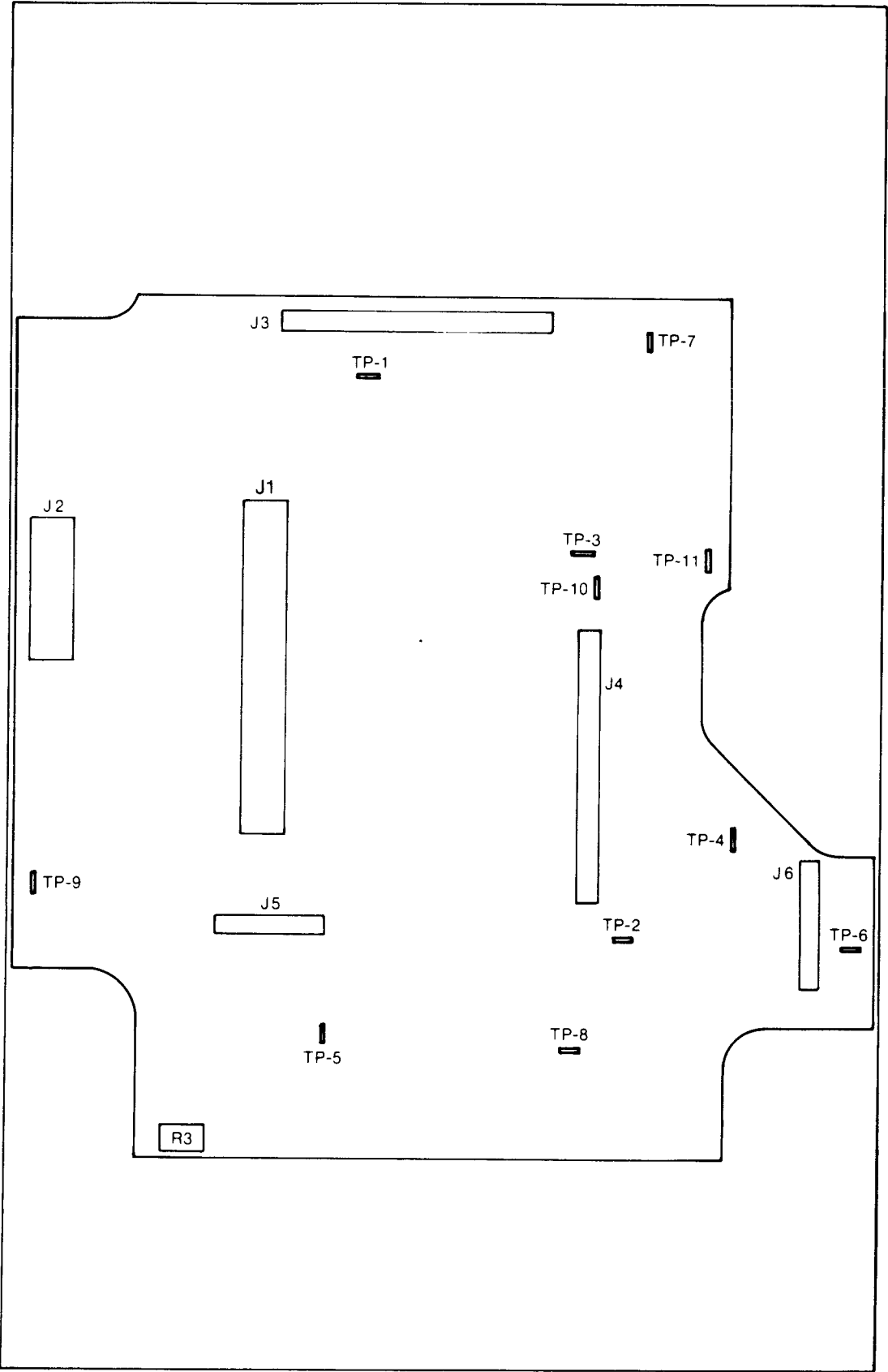

Figure 4C-1. Power Supply Test Points

PROCEDURE

Adjust R16 for 0.98V at TP1.

1. Gain access to the rear of the Display PCA by removing the top instrument cover.
2. Connect the DVM to measure the dc voltage at TP1 relative to the chassis.
3. Adjust R16 for $+0.9800 \pm .0005V$ dc.

4C-5. OUTPUT ASSEMBLY, A2A4, ADJUSTMENT

This procedure covers all of the adjustments on the A2A4 Output PCA, as follows:

1. R309, LEVEL DAC offset
2. R419, modulation oscillator level
3. R144, linearizer detector offset
4. R421, AM depth
5. R311, RF level
6. R227, Het level

These adjustments, as well as TP7, are accessible by removing the seven number 10 access screws in the module cover. Refer to Figure 4C-2 to identify the access screw corresponding to a particular adjustment.

Any adjustment can be made independently unless it is noted that it interacts with another adjustment. Interdependent adjustments must be done in the sequence presented. If more than one adjustment is necessary, do them in the sequence presented.

1. Level DAC Offset Adjustment

TEST EQUIPMENT

DVM

REMARKS

This adjustment is normally required only when U302 or any associated components are replaced or when the adjustment has been changed or has shifted.

CAUTION

This adjustment directly affects the output level and should not be changed indiscriminately.

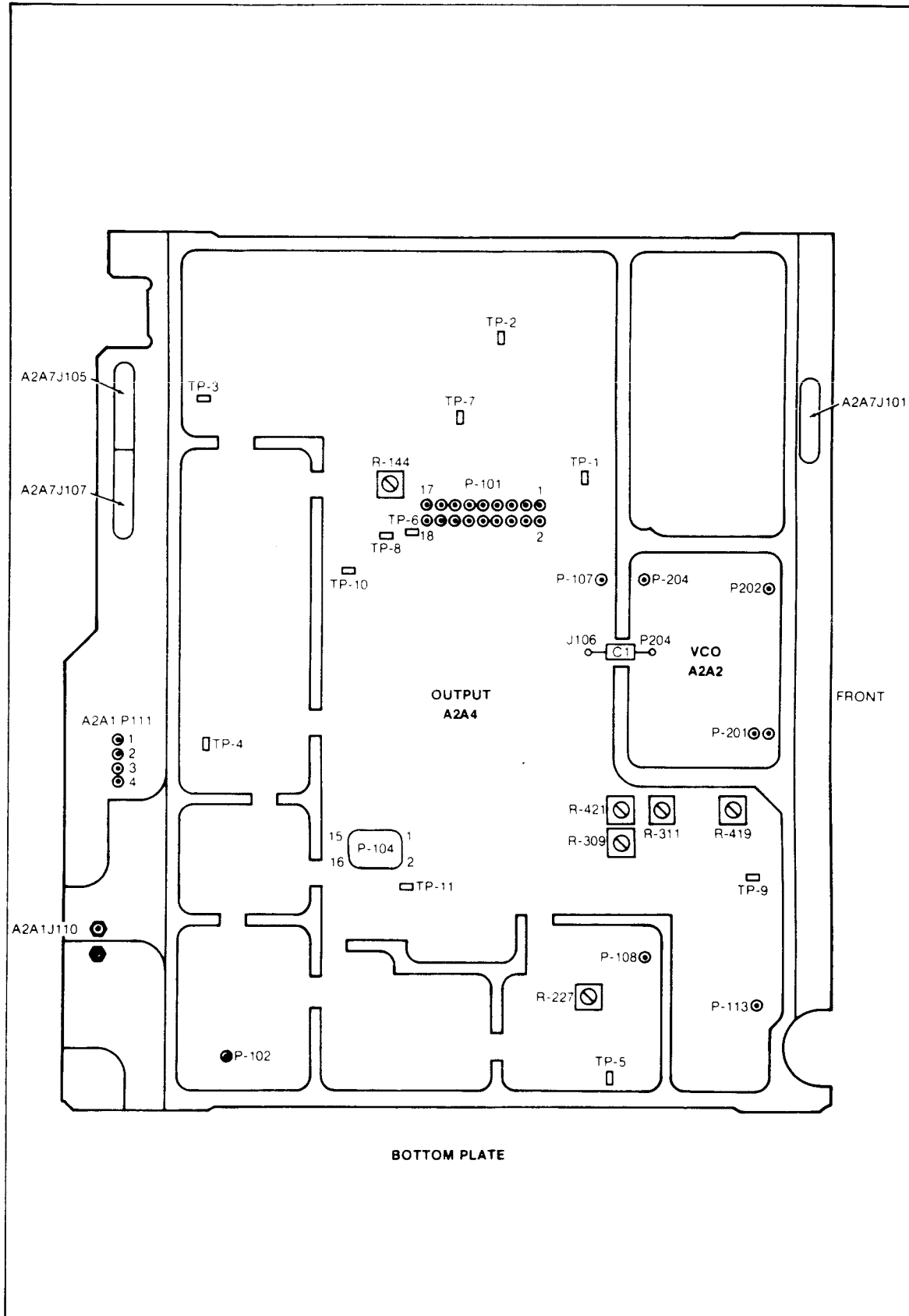

Figure 4C-2. Module Plate, Bottom View

PROCEDURE

The LEVEL DAC Offset, R309, is adjusted for 0 ± 0.5 mV at TP7 with the RF OUTPUT turned OFF.

- a. Gain access by removing the bottom instrument cover and removing the access screws for TP7 and R309.
- b. Program the UUT to [RCL][9][8], and program the RF OUTPUT to OFF.
- c. Connect the DVM to measure the voltage between TP7 and the power distribution connection point on the module plate.
- d. Adjust R309 for an indication of $+0$ mV \pm 0.5 mV.
- e. Program the UUT RF OUTPUT to ON.
- f. Replace the access screws.

2. Modulation Oscillator Level Adjustment

This adjustment sets the modulation oscillator level.

TEST EQUIPMENT

Modulation Analyzer

DVM

Low Frequency Synthesized Signal Generator (LFSSG)

REMARKS

The modulation oscillator adjustment is normally required only when components in the modulation oscillator or modulation switching circuits have been replaced or the adjustment has been changed or has shifted.

PROCEDURE

The AM depth, with internal modulation, is adjusted via R419 to equal the AM depth with a 1-volt peak external modulation signal, as measured with the Modulation Analyzer.

- a. Gain access to the access screws for R419 by removing the bottom instrument cover and the access screws for R419.
- b. Connect the output of the LFSSG to the UUT MOD IN connector and the DVM using a BNC tee.
- c. Program the UUT to [RCL][9][8], then program the UUT to 350 MHz, 7 dBm, and EXT AM at 90% AM depth.
- d. Program the LFSSG for 1 kHz and a voltage of 0.7071V rms, as measured by the DVM.
- e. Connect the UUT RF OUTPUT connector to the Modulation Analyzer RF input.

- f. Program the Modulation Analyzer to measure + Peak AM in a 0.3-kHz to 15-kHz bandwidth.
- g. Note the measured AM depth reading with the Modulation Analyzer.
- h. Turn off the UUT EXT AM control and turn on the INT AM control.
- i. Program the UUT for 1000-Hz modulation frequency.
- j. Adjust R419 for an AM depth equal to that noted in step g.
- k. Turn off the UUT INT AM control.
- l. Replace the access screw.

3. Detector Offset Adjustment

This adjustment sets the detector offset voltage.

TEST EQUIPMENT

Power Meter and Sensor

REMARKS

The UUT must be operated at room temperature for at least one hour, with the module plate cover in place, before continuing with this adjustment procedure.

This adjustment is normally required only when components in the detector or detector linearizer circuits have been replaced or when the adjustment has been changed or has shifted. If the Detector Offset is adjusted, perform the AM Depth Adjustment.

CAUTION

This adjustment directly affects the output level and should not be adjusted indiscriminately.

PROCEDURE

The detector offset adjustment, R144, is adjusted to provide a 20-dB change in output power for a 20-dB change in the LEVEL DAC with level correction disabled, and while operating in fixed range.

- a. Gain access for this adjustment by removing the instrument bottom cover.
- b. Program the UUT to [RCL][9][8], then program the UUT to 350 MHz and 12 dBm.
- c. Program the UUT to [SPCL][8][1] and [SPCL][9][1]. These special functions disable all level correction and enable amplitude fixed range.
- d. Remove the detector offset adjustment access screw from the bottom module plate cover.
- e. Zero the Power Meter.

MAINTENANCE
CALIBRATION ADJUSTMENTS

- f. Connect the Power Sensor to the UUT RF OUTPUT connector.
- g. Program the UUT to +12 dBm.
- h. Note the Power Meter reading.
- i. Program the UUT for -8 dBm, using the EDIT keys.
- j. Adjust the detector offset adjustment, R144, for a Power Meter reading 20 dB \pm 0.1 dB below the reading obtained in step h.
- k. Repeat steps g through j until the difference between the power measurements is 20 \pm 0.1 dBm. This adjustment should require no more than three iterations.

Program the UUT to +12 dBm, using the EDIT keys. Note the Power Meter reading.
- l. Program the UUT for +2 dBm using the EDIT keys. Verify that the Power Meter reading is 10 dB \pm .2 dB below the previous reading.
- m. Program the UUT for [SPCL] [0][0]. This enables amplitude level correction and disables amplitude fixed range.
- n. Disconnect the Power Sensor from the UUT and replace the Detector Offset adjustment access screw.

4. AM Depth Adjustment

TEST EQUIPMENT

DVM

Modulation Analyzer

LFSSG

REMARKS

The UUT must be operated at room temperature for at least one hour, with the module plate covers in place, before continuing with this adjustment procedure.

CAUTION

This adjustment directly affects the output level and should not be changed indiscriminately.

This adjustment is normally required only when components in the AM signal-processing circuits have been replaced, or if the adjustment has been changed or has shifted. If this adjustment is made, it is necessary to perform the RF level adjustment after the AM depth adjustment has been made.

PROCEDURE

Adjust the AM depth potentiometer R421 for 90% AM depth, as measured with the Modulation Analyzer when the UUT is programmed to 90% AM.

- a. Remove the AM depth adjustment access screw from the bottom module plate cover.

- b. Connect the output of the LFSSG to the UUT MOD IN connector and to the DVM, using a BNC Tee.
- c. Program the UUT to [RCL] [9][8], then program the UUT for 350 MHz, +1 dBm, and EXT AM at 90% AM depth.
- d. Program the LFSSG for 1 kHz and a voltage of 0.7071 rms, as measured by the DVM.
- e. Connect the UUT RF OUTPUT connector to the Modulation Analyzer input.
- f. Program the Modulation Analyzer to measure AM + Peak in a 0.05-kHz to 15-kHz bandwidth.
- g. Alternately measure + PEAK and - PEAK and adjust the AM Depth Adjustment, R421, until the readings are symmetrical, about 90%.
- h. Replace the AM depth adjustment access screw.

5. RF Level Adjustment

TEST EQUIPMENT

Power Meter and Sensor

REMARKS

The UUT must be operated at room temperature for at least one hour, with the module plate covers in place, before continuing with this adjustment procedure.

This adjustment is required if any of the following events occur:

The Output Assembly, A2A4, or the Attenuator/RPP, A2A5, has been replaced.

The AM depth adjustment is made.

The LEVEL DAC or any associated components are replaced.

The RF level adjustment has been inadvertently changed or shifted.

CAUTION

This adjustment directly affects the output level and should not be changed indiscriminately.

PROCEDURE

With the UUT programmed to +9 dBm, adjust the RF level adjustment, R311, for +9-dBm output as measured with the Power Meter.

- a. Program the UUT to [RCL] [9][8], then program the UUT to 350 MHz, +9 dBm, and turn all modulation OFF.
- b. Zero the Power Meter.
- c. Remove the RF Level Adjustment access screw from the bottom module plate cover.

MAINTENANCE
CALIBRATION ADJUSTMENTS

- d. Connect the Power Sensor to the UUT RF connector.
- e. Adjust the RF level adjustment, R311, for a reading of exactly +9 dBm on the Power Meter.
- f. Replace the RF level adjustment access screw.

6. HET Level Adjustment

TEST EQUIPMENT

Power Meter and Sensor

REMARKS

The UUT must be operated at room temperature for at least one hour, with the module plate covers in place, before continuing with this adjustment procedure.

This adjustment is normally required only when components in the het band circuits have been replaced or when the adjustment has been changed or has shifted.

CAUTION

This adjustment directly affects the output level and should not be adjusted indiscriminately.

PROCEDURE

With the UUT programmed to +9 dBm, adjust the het level adjustment, R227, for equal output power at 100 MHz and 350 MHz.

- a. Program the UUT to [RCL] [9][8], then program the UUT to 350 MHz and +9 dBm.
- b. Zero the Power Meter.
- c. Remove the het level adjustment access screw from the bottom module plate cover.
- d. Connect the Power Sensor to the UUT RF OUTPUT connector. Note the Power Meter reading.
- e. Program the UUT to 100 MHz.
- f. Adjust het level adjustment, R227, for a reading equal to that previously noted.
- g. Replace the het level adjustment access screw.

4C-6. SYNTHESIZER ASSEMBLY, A2A1 ADJUSTMENT

The following are the routine adjustments for the Synthesizer assembly, A2A1.

1. C153 10-MHz Adjustment

2. R82 FM Cal Adjustment
R90 Low-Rate Deviation Adjustment
R87 FM Flatness Adjustment
R220 Lower FM Distortion Adjustment
R206 Upper FM Distortion Adjustment

The following only need adjustment if the associated circuits are repaired.

3. L49 10-kHz Notch Filter Adjustment
L50 20-kHz Notch Filter Adjustment
4. R104 VCO Upper Clamp Adjustment
5. C206 800-MHz Oscillator Adjustment

Each of the following adjustment procedures is independent; that is, they can be done individually or in any sequence. Figure 4C-3 shows the top view of the module plate.

1. Reference Frequency Adjustment, C153

TEST EQUIPMENT

Frequency Standard
Oscilloscope

REMARKS

The accuracy of this adjustment depends on that of the Frequency Standard.

PROCEDURE

The UUT reference waveform is viewed on the Oscilloscope while triggering on the Frequency Standard. The 10-MHz adjustment, C153, is adjusted for a stationary display.

- a. Remove the instrument top cover and the 10-MHz adjustment access screw from the module plate cover.
- b. Connect the UUT rear panel 10 MHz IN/OUT to the Oscilloscope vertical input.
- c. Connect the Frequency Standard output to the Oscilloscope external trigger input.
- d. Set the UUT rear panel REF INT/EXT switch to INT, and set the vertical controls of the Oscilloscope to display the UUT 10-MHz signal.
- e. Set the Oscilloscope for external triggering, and adjust the timebase for 0.1 $\mu\text{s}/\text{div}$.
- f. Adjust C153 for a drift of less than one cycle per second.

**MAINTENANCE
CALIBRATION ADJUSTMENTS**

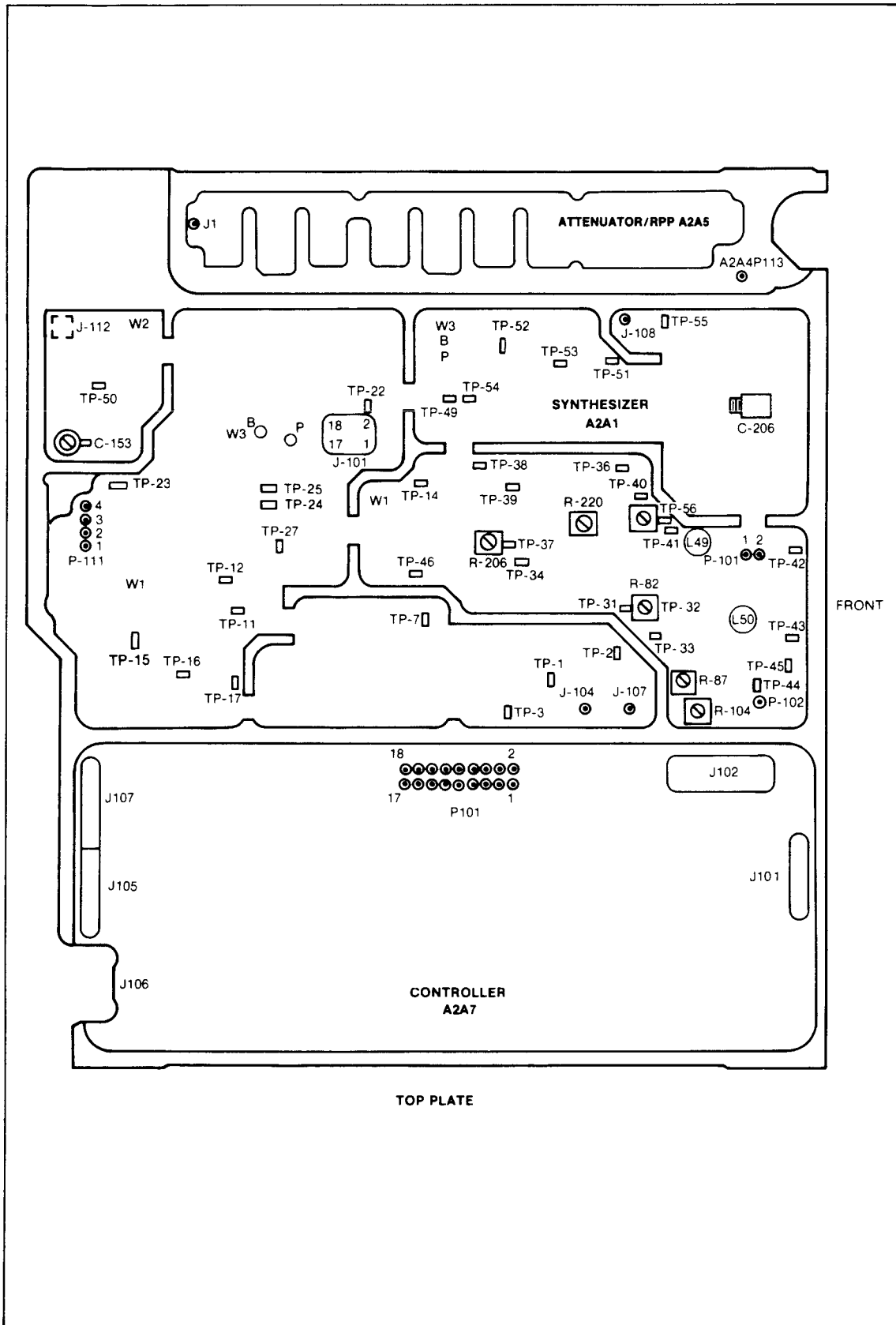

Table 4C-3. Module Plate, Top View

2. FM Adjustments, R82, R90, R87, R220, R206

TEST EQUIPMENT

Modulation Analyzer
LFSSG
DVM
Oscilloscope

REMARKS

The FM Cal adjustment, R82, sets the overall deviation accuracy; whereas, the Low-Rate Deviation adjustment, R90, equalizes the low and high rate deviation. The FM Flatness adjustment, R87, equalizes the deviation across the band from 0.2 to 10 kHz. The Upper and Lower FM Distortion adjustments minimize the distortion at low rates and high deviations.

PROCEDURE

The FM deviation of the UUT, as measured with the Modulation Analyzer, is adjusted to agree with the programmed deviation at 10-kHz, 0.2 and 0.5-kHz rates by adjusting R82, R90, and R87, respectively. The distortion at 400-kHz deviation and 40-Hz rate is minimized visually on an Oscilloscope by adjusting R220 and R206.

- a. Remove the instrument cover and the FM CAL, FM flatness, Low-Rate Deviation, and Upper and Lower FM Distortion adjustment access screws from the cover of the module plate.
- b. Connect the output of the LFSSG to the UUT MOD IN connector and to the DVM, using a BNC tee.
- c. Connect the UUT RF OUTPUT to the Modulation Analyzer input.
- d. Connect the Modulation Analyzer Modulation Output to the Oscilloscope.
- e. Program the Modulation Analyzer to measure FM + peak. Set all filters off.
- f. Program the UUT to the [RCL][9][8]. Then program the UUT to 385.5 MHz, 7 dBm, EXT FM, 99.9-kHz deviation.
- g. Program the LFSSG to 10 kHz and 0.7071V rms, as measured by the DVM.
- h. Adjust R82 for 100.0 kHz, as measured by the Modulation Analyzer.
- i. Program the LFSSG to 0.2 kHz and 0.7071V rms, as measured by the DVM.
- j. Adjust R90, the low-rate deviation for 100.0 kHz, as measured on the Modulation Analyzer.
- k. Program the LFSSG to 0.5 kHz and adjust R87 for 100.0 kHz, as measured on the Modulation Analyzer.
- l. Repeat steps g through k until the deviation flatness is 100.0 kHz \pm 0.3 kHz.

MAINTENANCE
CALIBRATION ADJUSTMENTS

- m. Turn the UUT EXT FM off, and note the Modulation Analyzer peak deviation (noise) reading.
 - n. Turn the UUT EXT FM on.
 - o. Program the LFSSG to 10 kHz and 0.7071V rms, as measured by the DVM.
 - p. With the Modulation Analyzer, alternately measure +peak and -peak FM, and adjust R82 so the readings are symmetrical, about 99.9 kHz plus the noise noted in step m.
 - q. Program the LFSSG to 40 Hz and 0.7071V rms, as measured by the DVM.
 - r. Program the UUT to 400-KHz deviation.
 - s. Adjust R220 and R206 to minimize the distortion (glitches) appearing on the waveform.
3. L49 10-kHz and L50 20-kHz Notch Filter Adjustments

TEST EQUIPMENT

RF Spectrum Analyzer
LFSSG

REMARKS

These adjustments are normally not required unless L49, L50, C123, C99, C124, C126 or C125 are replaced, or unless the Generator has been subjected to severe usage.

PROCEDURE

The 10-kHz and 20-kHz notch adjustments, L49 and L50, are adjusted for sideband-level nulls using the RF Spectrum Analyzer.

- a. Remove the instrument and the module plate top covers.
- b. Connect the LFSSG to TP56 (high) and TP36 (low), using clip leads.
- c. Program LFSSG to 10 kHz and 0.2V rms, terminated.
- d. Connect the UUT RF OUTPUT to the RF Spectrum Analyzer input.
- e. Program the UUT to 300 MHz and +13 dBm.
- f. Adjust the RF Spectrum Analyzer to display the signal centered on the display.
- g. Set the span to 10 kHz/division and 1-kHz bandwidth. The 10-kHz sidebands should be visible.
- h. Adjust L49 to minimize the 10-kHz sidebands.
- i. Program the LFSSG to 20 kHz.
- j. Adjust L50 to minimize the 20-kHz sidebands.

4. VCO Upper Clamp Adjustment, R104

TEST EQUIPMENT

Frequency Counter

REMARKS

This adjustment is normally required when the VCO is replaced or when the Generator has been subjected to severe usage.

PROCEDURE

The UUT PLL loop is disabled to cause the VCO frequency to be at the upper limit of its range, then R104 is adjusted for 530 MHz.

- a. Remove the instrument and module plate top covers.
- b. Connect UUT RF OUTPUT to the Frequency Counter input.
- c. Program the UUT to [RCL] [9][8]; then program the UUT for 500 MHz and +13 dBm.
- d. Using a clip lead, short TP14 to ground to cause the VCO to go to the upper frequency limit.
- e. Adjust R104 for 530 MHz \pm 1 MHz.

5. 800-MHz Oscillator Adjustment, C206

TEST EQUIPMENT

Frequency Counter
DMM

REMARKS

This adjustment is normally not required unless components in the 800-MHz oscillator are replaced or the Generator has been subjected to severe usage.

PROCEDURE

The PLL control voltage operating point is adjusted to 16V while the loop is phase locked.

- a. Remove the instrument and the module plate top covers.
- b. Program the UUT to [RCL] [9][8]; then program 200 MHz.
- c. Connect the DMM to measure voltage between TP53 and the chassis.
- d. Adjust C206 for 16.0V \pm 0.5V.

4C-7. DEVIATION METER ASSEMBLY, A4A1 ADJUSTMENT

Figure 4C-4 shows the top view of the deviation meter plate.

TEST EQUIPMENT

DVM
HFSSG
Modulation Analyzer

REMARKS

The ADC OFFSET, R58, adjusts the analog-to-digital converter to zero counts with zero volts applied. The FM GAIN adjustment, R30, calibrates at 400-kHz deviation. The X10 GAIN adjust, R31, sets full-scale at 50-kHz deviation. The OFFSET, R29, sets the DC to zero volts. The \pm peak select balance is adjusted by \pm PEAK, R32.

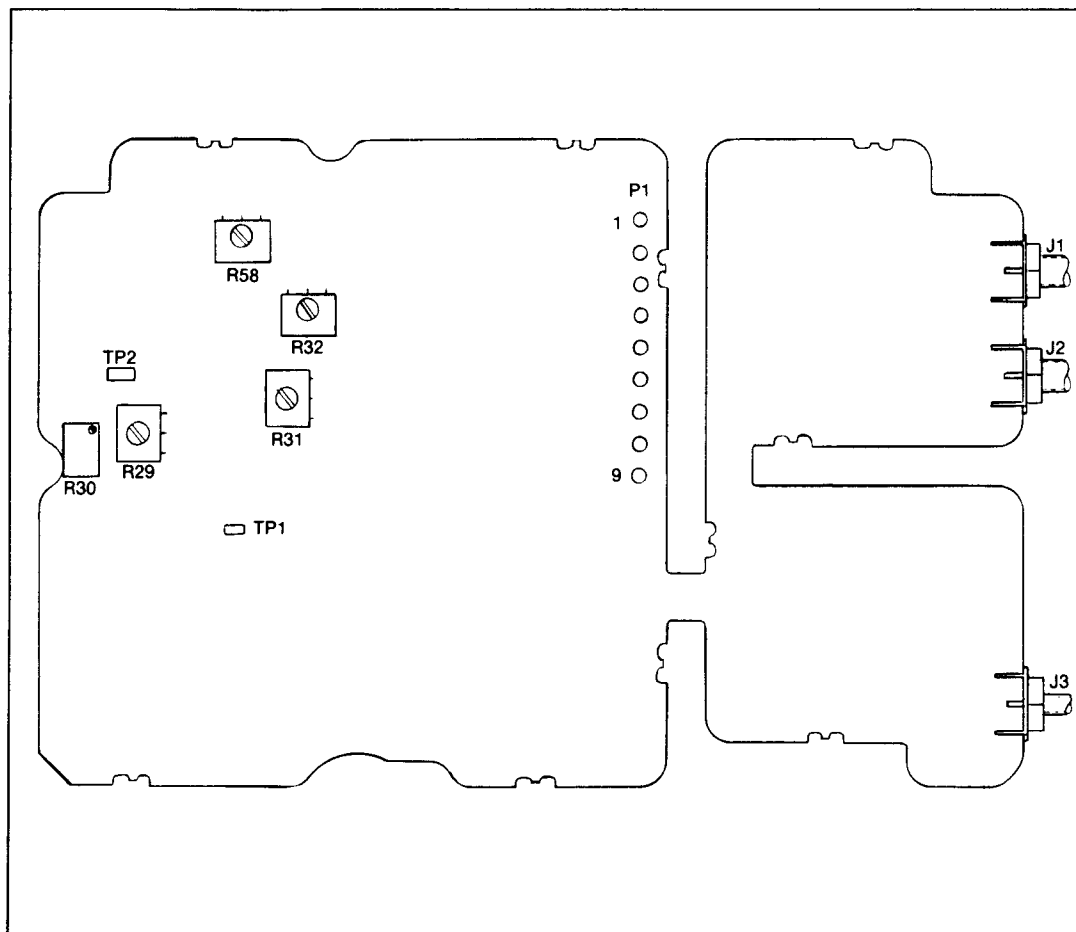

Table 4C-4. Deviation Meter Module, Top View

PROCEDURE

The FM deviation of the HFSSG is measured with the Modulation Analyzer and the UUT, and adjustments are made to equalize the two.

1. Connect the HFSSG to UUT DEVIATION METER INPUT and Modulation Analyzer RF input. Use a 6 dB pad at the Modulation Analyzer RF input. Set the UUT to Meter Mode ([SPCL] [6][1]) at 500 MHz.
2. Program the HFSSG to 500 MHz, 7 dBm, 400-kHz deviation.
3. Program the Modulation Analyzer to measure FM + peak in a 0.02-kHz to > 20-kHz bandwidth.
4. Short TP2 to ground. Adjust R58 (ADC OFFSET) so that the front panel display reads 1 kHz. Adjust R58 so that the display changes from 1 to 0 kHz.
5. Connect the DVM to TP1. Adjust R29 (OFFSET) for $0V \pm 100$ mV at TP1. Disconnect DVM.
6. Program the HFSSG to INT FM, 1-kHz deviation.
7. Adjust R30 (FM GAIN) for the same deviation reading on the Modulation Analyzer and UUT.
8. Program the HFSSG to 50.0-kHz deviation. Set the UUT to the 50-kHz Range (press "500/50 KHZ RANGES" [400/1000]).
9. Adjust R31 (50 KHZ GAIN) for the same deviation reading on the Modulation Analyzer and the UUT.
10. Set the Modulation Analyzer and the UUT to measure FM - peak (press " \pm PEAK" [INT FM]).
11. Adjust R32 (\pm PEAK) for the same deviation reading on the Modulation Analyzer and the UUT.

Section 4D

Troubleshooting and Repair

4D-1. INTRODUCTION

Usually, you can repair the Generator most easily by identifying the defective module and replacing it through the Module Exchange Program. Alternately, you may wish to troubleshoot down to the component level and replace the defective part. This section of the manual provides the necessary information for both methods of repair.

After any module repair or replacement, you should do the Performance Tests to verify the performance of the Generator. Signal Generator problems are generally caused by operator error, out-of-spec performance, or catastrophic failure. The correction strategy is different in each case.

The Generator detects and indicates most operator errors. Some errors, however, are not detected and may be mistaken for an out-of-spec condition. Those operator errors that are detected are indicated with either a steady or flashing UNCAL indicator. Consult the Generator Specifications in Table 1-1 and in Section 2 of this manual for more information on operation of the Generator.

Out-of-spec performance is usually corrected by performing the appropriate adjustment procedure(s). Use the Performance Tests to determine which parameters need adjustment. Refer to the paragraphs on adjustment in this section for more information.

If a problem is not an operator error and is not corrected by adjustment, the Generator has a catastrophic failure. Then the task is to isolate the fault and make appropriate repairs. The UNCAL and self-test failure codes usually provide a good indication of the cause of the problem. Using the Performance Tests in this situation may help to determine which parameters are not affected.

4D-2. MODULE REPLACEMENT

This repair method involves identifying and replacing the problem module. The replacement module may be obtained by using the Module Exchange Program, or a replacement module may be taken from your spare module stock, which may then be restored using the Module Exchange Program.

Use the information in the Troubleshooting section to diagnose the problem. If you need help in identifying the problem module, call your local Fluke Technical Center for troubleshooting assistance. Once the Fluke service technician believes the problem module is identified, a replacement module can be shipped prepaid by an overnight air carrier.

After you verify that the replacement module corrects the problem, return the defective module, using the shipping container; include the prepaid return shipping papers and label.

NOTE

The Attenuator, Output, and VCO assemblies are individually calibrated, and the correction data are stored in the associated calibration EPROMS.

CAUTION

If the Attenuator, Output, or VCO assemblies need calibration or if any non-field replaceable part needs repair, order a replacement through the Module Exchange Program.

To order a replacement module, use the part number shown in Table 4D-1 and specify a Module Exchange part. To order any new assembly, use the appropriate part number as listed in Section 5. The following paragraphs describe the available exchange modules, how to install them, and how to adjust the Generator, if necessary, after installation.

4D-3. Power Supply PCA, A3A1

The Power Supply PCA comes complete with the 5V regulator, A1U3, its socket, and a set of insulated washers for all of the chassis-mounted regulators.

No adjustment is required after installation of the new PCA, but you should verify the power supply voltages, using the last step of the Power Supply Adjustment procedure in this section.

4D-4. Synthesizer PCA, A2A1

After the new Synthesizer PCA has been installed, perform the FM CAL, VCO CLAMP, and 10-MHZ adjustments, as described in the Synthesizer Adjustment procedure in Section 4C of this manual.

Table 4D-1. Module Exchange Assemblies

A1A1 Display PCA	(P/N 738609)
A1A2 Switch PCA	(P/N 738591)
A2A1 Synthesizer PCA	(P/N 774513)
A2A2 VCO PCA	(P/N 792705)
A2A4 Output PCA	(P/N 774521)
A2A5A4 Attenuator/RPP Assembly	(P/N 752667)
A2A5A5 Relay Driver/RPP PCA	(P/N 752816)
A2A7 Controller PCA	(P/N 774539)
A3A1 Power Supply PCA	(P/N 744052)
A3A3 IEEE-488 Interface Assembly	(P/N 774562)
A4A1 Discriminator PCA	(P/N 774554)
A4A2 A/D PCA	(P/N 774547)

4D-5. VCO PCA, A2A2

The VCO assembly comes with its associated VCO Calibration EPROM. This EPROM replaces the old one installed on the Controller PCA, A2A7. After installing the new VCO assembly, you should do the FM CAL and VCO CLAMP adjustments. These adjustments are presented under the Synthesizer Adjustment procedure.

A plug-in coupling capacitor is used to interconnect the VCO and Output PCAs, thus eliminating the need for a soldering iron when replacing this assembly.

4D-6. Output PCA, A2A4

The Output assembly comes with its associated Output Calibration EPROM. This EPROM replaces the old one installed on the Controller PCA. After installing the new Output assembly, perform the level DAC offset, the RF level adjustment procedure, the het level adjustment procedure, and the FM CAL adjustment procedure. These procedures are found in the Calibration Adjustment section of this manual.

A plug-in coupling capacitor is used to interconnect the VCO and Output PCAs, eliminating the need for a soldering iron when replacing this assembly.

4D-7. Controller PCA, A2A7

The Controller assembly comes without the three calibration EPROMs. Therefore, it is necessary to move these EPROMs from the old Controller to the new Controller. Remember to set the option status switch. No adjustments are required.

4D-8. Display PCA, A1A1

After installing a new Display PCA, the Modulation Indicator adjustment should be done. The procedure is presented under the Display Adjustment Procedure.

4D-9. Attenuator/RPP Assembly, A2A5

The Attenuator/RPP comes complete with the housing, Attenuator/RPP PCA (A2A5A4), Relay Driver/RPP PCA (A2A5A5), and the matching Attenuator Calibration EPROM. The Attenuator comes ready to install. The matching EPROM replaces the Attenuator calibration EPROM on the Controller PCA (A2A7). After you install the new Attenuator assembly, perform the RF level adjustment procedure on the Output PCA (A2A4), as explained in the Calibration Adjustments section of this manual. The Relay Driver/RPP PCA (A2A5A5) can be ordered separately through module exchange.

4D-10. IEEE-488 PCA, A3A3

The IEEE-488 assembly comes complete with panel, frame, and connector and is ready to plug in. No adjustments are required after installation.

4D-11. Discriminator PCA, A4A1

After installation, perform the adjustments specified for the A4A1 Discriminator PCA in the Calibration Adjustments section of this manual.

4D-12. A/D PCA, A4A2

No adjustments are needed after installation.

4D-13. PARTS REPLACEMENT

After reading the information presented in Section 3 (the Theory of Operation and troubleshooting information), an experienced technician should be able to isolate the defective component and replace it. The Schematics are presented in Section 8. (Section 6 contains the Schematics for the options.)

You can replace most parts by using standard methods. The parts requiring special attention are the chip components located on the A2A2 VCO PCA. You should replace the chip components by using a 600°F soldering iron (such as an Ungar 50T7 with a number 76 heater and a number 88 tip) and 2% silver solder paste (such as Electro Science Fabrication SP - 37D1 or similar wire solder).

4D-14. TROUBLESHOOTING

To isolate a fault, it is important to note the conditions under which the symptoms are observed and if the symptoms change with different states of the instrument, such as: different RF bands or levels, only when FM is on, only under remote control, etc.

If the symptom is a blank front panel or no response to keystrokes, the fault is most likely a digital problem or a power supply problem. If the power supply and cables are good, go to the digital troubleshooting paragraphs in this section.

If the front panel appears to function properly, but the RF output is abnormal or there is a flashing UNCAL indication, the cause is likely an analog circuit problem (although it could be a control problem).

A properly operating front panel indicates that the majority of the Controller circuitry is functional. It is possible, however, that a digital control problem could exist and cause the RF output to be incorrect. If a digital problem is suspected, first check the power supply, then go to the Digital and Control troubleshooting paragraphs.

4D-15. Service Special Functions

There are several special functions that assist in the maintenance of the instrument.

- Special Function 03, Display Check

All display segments are lit until a key is pressed.

- Special Function 04, Key Check

For each key pressed, the code is displayed in the FREQUENCY display field. Pressing the [CLR LCL] key exits this check. If no keys are pressed, the test times out after approximately 8 seconds.

- Special Function 15, Latch Test

Special function 15 initiates a built-in latch control test that is useful in verifying that the Controller is sending valid data to the latches of the Output and Synthesizer assemblies. This special function sends an alternating bit pattern (10101010 binary) to each 8-bit latch, and displays "Latch AA". Pressing the EDIT [] key changes the bit pattern to (01010101 binary), and "Latch 55" is displayed. Pressing the EDIT [] key changes the pattern back to 10101010. Pressing any other key causes the instrument to exit the test.

CAUTION

This special function is intended as a troubleshooting tool to check the operation of the digital circuitry and the latches on the analog assemblies. Since the Generator is programmed to an abnormal state, its output is turned off by programming full attenuation.

- Special Functions 83 Through 86 Alternate Attenuators

Special functions 83 through 86 program alternate 24-dB attenuators. The alternate 24-dB attenuators are normally used only when low levels are programmed too low to be verified with a power meter during service. These special functions allow the alternate attenuators, A242L through A245L, to be programmed one at a time, thus keeping the level high. The first 24-dB attenuator, denoted A241L, is automatically programmed for levels between -17.0 dBm and -11.1 dBm with AM off. These special functions allow the other attenuators, A242L through A245L, to be programmed in the same range.

Special functions 83 through 86 also turn off relative amplitude, amplitude-fixed range, and all modulation; these special functions also turn the RF and level correction on. If the level is not in the specified range, -12 dBm will be programmed. Any new entry that normally programs the attenuators causes the default (normal) attenuators to be programmed.

4D-16. UNCAL Conditions

There are two hardware fault detectors: the unlock detector on the Synthesizer PCA and the unlevel detector on the Output PCA. These two fault detectors are constantly monitored by the Controller, and if asserted, cause a flashing UNCAL indication. The detectors are also used during the self test to check the general health of the Generator.

It is very important to interrogate and note the UNCAL code if there is an UNCAL indication.

If the unit has an UNCAL condition, interrogate the UNCAL code by pressing the [STATUS] key and interpret the code (see Table 2-5 in this manual). Take note if the code indicates that either UNLOCK or UNLVL conditions have been asserted. Other codes denote overrange or underrange conditions (operator errors) that should be cleared but are not pertinent to troubleshooting.

Usually the unlevelled UNCAL code indicates a problem on the Output PCA, whereas, an unlocked UNCAL code indicates a problem on the Synthesizer PCA. Be aware that it is possible to have an unlevelled UNCAL condition due to a problem with the Synthesizer PCA that is not detected by the UNLOCK detector.

For a more complete analysis of the symptoms, it is a good idea to check for a different UNCAL code when other RF bands, levels, or functions (FM or AM) are selected. For example, if the code indicates that UNLOCK is asserted only with FM on, and not with FM off, it may be indicating an overmodulation condition. See Table 1-1. Signal Generator Specifications, for the FM limitations.

4D-17. Self-Test Description

The self test is started whenever the Generator is turned on. The self test may also be started by pressing [SPCL][0][2]. If the Generator fails any of the self tests, the self-test failure report is displayed until any key is pressed. You can also press [SPCL][1][1] to display the self-test report. The report is presented in four fields, as shown in Table 4D-2.

A minus sign in the Frequency Display indicates that the self test was aborted by a front panel entry.

Table 4D-2. Self-Test Display Field

MODULATION			FREQUENCY						AMPLITUDE			
A	A	A	-	B	B	B	C	C	C			

The four groups (denoted by the A's, B's, C's and D's) in the self-test report correspond to different test categories. These tests are described below, including a tabulation of the Generator instrument state and the test codes that result if any test fails to achieve the expected result. Understanding how these tests are done can provide you with a better understanding of the results and how the results relate to other symptoms. A successful self test is reported with all zeros.

During the self test, the step attenuator is programmed to maximum attenuation and the internal frequency reference is selected. The analog circuit tests make use of the unlevelled (UNLVL) and unlocked (UNLCK) status detectors, whereas, the digital circuit tests make use of write/read techniques.

4D-18. AAA FIELD

AAA is the result of the AM and FM tests. During these tests, level correction is applied. During the four AM tests, a normal AM depth, which should produce a leveled condition, and an abnormally high AM depth, which should provide an unlevelled condition, are set for each modulation frequency. During the FM test, a normal FM deviation is set, which should produce a locked condition. Table 4D-3 shows the AAA Field AM and FM tests.

Table 4D-3. AAA Field AM and FM Test

AAA (CODE)	FREQ (MHZ)	LEVEL (DBM)	AM (%)	MOD FREQ (HZ)	KV DAC	FM DAC	FM RANGE	EXPECTED RESULT
001	520	10.7	30	400	n/a	n/a	n/a	Leveled
002	520	16	127	400	n/a	n/a	n/a	Unleveled
004	520	10.7	30	1000	n/a	n/a	n/a	Leveled
010	520	16	127	1000	n/a	n/a	n/a	Unleveled
020	280	-10	n/a	400	Normal	1023	4	Locked

4D-19. BBB FIELD

BBB is the result of the synthesizer tests. In the first three test steps, the Synthesizer assembly's main PLL operation is verified by programming a large change in frequency. This should cause a momentary unlocked condition that should clear as the frequency settles to the new frequency.

In the next three steps, the synthesizer is checked by programming 225 MHz, which is outside the normal operating frequency range and should result in an unlocked condition. Then, 385 MHz is programmed, which should result in a locked condition. Next, 550 MHz is programmed, which is again outside the normal range and should result in an unlocked condition.

Finally, all frequency reference circuitry is turned off, which should produce an unlocked condition, and then turned on, which should produce a locked condition. Table 4D-4 shows the BBB Field test results.

Table 4D-4. BBB Field Test Results

BBB (CODE)	SYNTH. FREQ. (MHZ)	MAX. WAIT (MS)	XOENL BIT	EXPECTED RESULT
001	245	120	0	Locked
002	520	5	0	Unlocked
004	520	95	0	Locked
010	225	120	0	Unlocked
020	385	120	0	Locked
040	550	120	0	Unlocked
100	385	120	1	Unlocked
200	385	200	0	Locked

4D-20. CCC FIELD

CCC is the result of the digital tests. The IEEE-488 is verified by writing data to the IEEE-488 chip, A3A3U1, and then by reading it back and checking for the expected response.

The Generator RAM is verified by writing data to each memory location and checking that the same data can be read back. Both the off-chip RAM (U25) and the on-chip RAM (U1) are tested in this manner. The RAM test is only done during the power-on self test. The data in each of the three calibration EPROMs (VCO (U23), Output (U24), and Attenuator (U26)) are summed and compared with a checksum.

The data in each word of the two program EPROMs (U21, U22) are successively summed and rotated by two. The result of this procedure is compared with a checksum for each EPROM. Table 4D-5 shows the CCC field results.

Table 4D-5. CCC Field Test Results

CCC (CODE)	DIGITAL TEST
001	IEEE-488 test
004	RAM test
010	Attenuator calibration EPROM checksum
020	Output calibration EPROM checksum
040	Synthesizer calibration EPROM checksum
100	Lower program EPROM checksum
200	Upper program EPROM checksum

4D-21. DDD FIELD

DDD is the result of the Output filter tests. During these tests, the level is programmed to +13.0 dBm with level correction applied. The low-pass filters on the A2A4 Output assembly are tested by setting the frequency near the high end of each of the four half-octave non-hot bands and checking for a leveled condition. Then, the frequency is set above the cutoff frequencies of two of the filters, and the output is checked for an unlevelled condition. Table 4D-6 shows the DDD field Results.

Table 4D-6. DDD Field Test Results

DDD (CODE)	FREQ (MHZ)	MIDL	HAOCTH	EXPECTED RESULT
001	349.99999	0	1	Leveled
002	520.00000	0	0	leveled
004	244.99999	1	1	leveled
020	490.00000	0	1	unleveled
040	224.00000	1	0	unleveled

4D-22. Check Output Signal

Check the Generator output signal with a Spectrum Analyzer or a Counter at various frequencies on each of the three RF bands and at the state where an UNCAL condition exists. If the frequency is incorrect or erratic, check the power supply first. If the power supply functions properly, go to the Synthesizer troubleshooting paragraphs. Table 4D-7 shows the band, filter, and frequency programming data for the output frequency (at the source).

Table 4D-7. Band, Filter, and Frequency Programming Data

OUTPUT FREQUENCY (F_o)	MIDL	HAOCTH	HETL	SHETH	SYNTH. FREQ (F_s)
0.01- 244.99999 MHz	1	1	0	1	$(800 + F_o) / 2$
245 - 349.99999 MHz	0	1	1	0	F_o
350 - 520.00000 MHz	0	0	1	0	F_o
1 = TTL High 0 = TTL Low					

You can also use the Spectrum Analyzer to verify that the modulation functions are working. If a modulation problem exists, check the power supply, then go to the appropriate AM or FM troubleshooting paragraphs.

If the frequency is stable and correct, but the output level is abnormal, the problem is most likely in the Output PCA. Check the power supply, then go to the Level Troubleshooting paragraphs in this section of the manual.

When you have a clear knowledge of the symptoms and the conditions under which the UUT fails, the next task is to isolate the problem. Remove the top and bottom instrument covers and visually inspect the interior for loose cables, connectors, etc. Also be alert for the characteristic odor of burned resistors.

WARNING

DO NOT INTERRUPT THE PROTECTIVE GROUNDING CONNECTION. TO DO SO WOULD CREATE A POTENTIAL SHOCK HAZARD THAT COULD RESULT IN PERSONAL INJURY. SECURE THE INSTRUMENT AGAINST UNINTENDED OPERATION IF IT IS LIKELY THAT THIS PROTECTION HAS BEEN IMPAIRED. USE ONLY 250V FUSES OF THE PROPER CURRENT RATING.

WARNING

BECAUSE THE PROCEDURES DESCRIBED HERE ARE PERFORMED WITH POWER APPLIED TO THE SIGNAL GENERATOR AND WITH PROTECTIVE COVERS REMOVED, TESTING SHOULD BE PERFORMED ONLY BY TRAINED SERVICE PERSONNEL WHO UNDERSTAND THE HAZARDS INVOLVED.

CAUTION

To prevent damage to the Generator, turn off the instrument before removing any PCAs.

4D-23. Check Power Supply Voltages

CAUTION

To prevent damage to the Generator, turn off the instrument before disconnecting any power distribution cables.

Check all power supply voltages. Table 4D-8 gives the expected dc and ripple voltages at key test points. If one supply voltage is unusually low, this could indicate an abnormal load on that supply due to a fault. To isolate the fault, check the abnormal voltage before and after disconnecting (one at a time) the power cables to the Controller, Synthesizer, Attenuator, and the cable from the Controller to the front panel.

Table 4D-8. Power Supply Characteristics

SUPPLY	UNREGULATED VOLTAGES			REGULATED VOLTAGES		
	@TP	V dc	Ripple(Vpp)	@TP	V dc	Ripple(mVpp)
+37	9	47	0.5	5	36.9 to 37.1	2
+15 Syn	7	22	0.5	11	14.5 to 15.7	0.5
+15 Out				3	" "	"
-15	8	-23	0.2	2	-14.5 to -15.7	"
+5	10	9	1	4	4.75 to 5.25	1
+18	1	18	2.5	None	None	None

Table 4D-8 lists the typical dc and ripple voltages (relative to ground connection on the module plate) at the key test points of the Power Supply PCA, A3A1. These characteristics apply for [RCL] [9][8].

The unregulated dc and ripple voltages are those expected with a line voltage of 115V ac at 60 Hz. The dc voltages are expected values, as measured with a digital voltmeter with respect to the power supply ground connection on the module plate.

The ripple voltages are expected values, as measured with an oscilloscope with respect to the power supply ground connection on the module plate, and are the peak-to-peak values of the 120-Hz waveform.

The characteristics of the unregulated +18V-relay supply depend directly on the line voltage and the load (the state of the instrument). For example, at 115V ac:

At 50 MHz and 13 dBm, Vdc is typically 20V with 0.25V (peak-to-peak) ripple.

At 50 MHz and RF off, Vdc is typically 20.9V with 0V ripple.

4D-24. DIGITAL AND CONTROL TROUBLESHOOTING

If the symptoms indicate a digital or control problem, the following suggestions may help you isolate the fault to a particular functional circuit. In this manual, refer to the schematic diagrams in Section 8, and refer to Section 3 for the Theory of Operation.

First, verify that all assemblies are receiving the correct voltages from the power supply.

The most obvious symptom of failure in the Controller assembly is a blank front panel. A properly operating front panel indicates that most of the Controller circuitry is functional. If the front panel is totally blank or unresponsive to any keystrokes, the microprocessor kernel should be checked first. See the paragraphs entitled Microprocessor Kernel in this section.

If the front panel is operating correctly but the RF output is incorrect, determine if the fault is on the Controller side of connector P101. The control to most of the audio and RF analog circuitry passes through P101 via buffers U15 and U16 on the Controller PCA, A2A7.

4D-25. Control Activity

This can be checked by verifying data activity on the data and address lines of P101. The meter module can be removed to examine the Controller. Program the bright digit for 100-Hz resolution in the FREQUENCY display. While pressing the EDIT $\$B$] key, observe with an oscilloscope the activity on P101. Pressing one of the EDIT keys sends bursts of frequency and level control data through the buffers.

Although it is difficult to determine if the data (BD0-7) and address (BAB0-2) signals on P101 are valid at any given time, the most common failures seen at this point are totally inactive signals. Between bursts, the data and address signals are in the high impedance state (tri-stated). Be careful not to confuse this high impedance state with total inactivity. Observing these signals on a known good unit may be helpful.

If signals are found to be totally inactive, inspect the buffer control signals on U15 (pin 1), and U16 (pins 1 and 19) of the Controller, A2A7. If the buffer control signals are active, check the buffer inputs that correspond to the inactive outputs. If the inputs show activity, replace the buffer and again check the signals. If, however, the inputs to the buffers are also inactive, trace the signals back and determine the fault location.

If all data and address signals show activity and their timing roughly corresponds to the select signals BSEL0L and BSEL1L, assume for now that the Controller is sending the correct data and continue on.

4D-26. Latch Control

Use the [SPCL] [1][5] keys to check each available latch on the RF circuit boards to verify that the correct data is reaching them. Passing this test is a good indication that the fault is not in the Controller.

If an IEEE-488 Bus Controller is available, additional bit-level control of the hardware is available by using the monitor commands (see Section 2). These commands allow you to program the DACs directly or read and write data to any desired location.

4D-27. Microprocessor Kernel

Connect an oscilloscope probe to the external-clock input of A2A7 U1 pin 2. There should be a symmetrical 10-MHz square wave with an adequate TTL logic level. If the signal deviates from this description, refer to Section 3, Theory of Operation, for assistance in troubleshooting the clock-oscillator circuit.

4D-28. Power Reset

Connect an oscilloscope probe to the $\overline{\text{RESET}}$ input (pin 22) of U1. The signal should generate a low to high transition on power-up and remain high during normal operation. Turning the power on and off generates active low reset pulses to U1. If you suspect a problem with the reset circuit, refer to Section 3, Theory of Operation, and troubleshoot the reset circuitry.

4D-29. Microprocessor Inputs

Input pins to U1, $\overline{\text{CRUIN}}$ (pin 13), $\overline{\text{INTI}}$ (pin 15), $\overline{\text{HOLD}}$ (pin 18), $\overline{\text{NMI}}$ (pin 21), and $\overline{\text{READY}}$ (pin 23), should all be high. If any of these signals are not high, correct the fault before continuing on.

4D-30. IEEE-488 Interrupt

Verify that the IEEE-488 Interface interrupt signal, IEINTL, is in the inactive (high) state. If IEINTL is active, either troubleshoot the interface to the IEEE-488 Interface, or temporarily bend out pin 14 of U1 and tie it to +5V.

After completing the above steps, there should be activity on the address, data, and control lines as the microprocessor executes instructions.

4D-31. Microprocessor Bus

The dynamic nature of microprocessor bus circuitry makes it very difficult to verify the data transmitted at any given time. However, most common bus faults show recognizable symptoms. Look at each of the data (D0 to D7), address (A0 to A15), and bus control (CLKOUT, DBINL, WEL, MEML) signals with an oscilloscope.

Suspect inactive signals or signals that enter invalid logic states. Also compare the driver inputs and outputs of buffered signals. A combination of observation and experience is helpful here. An ohmmeter or a pulse generator may be useful in further investigating suspected signals.

4D-32. Address Decoder

Several levels of address decoding are used to select all the memory and I/O devices. The inputs to the address decoders come from the buses and present challenges similar to troubleshooting the buses. A suggested approach is to first choose a decoding path to a particular device or group of devices. Start at the highest level of decoding, and, one at a time, verify that each part in the path is good.

4D-33. Display and Controls

If the display shows signs of activity, but has missing or bright digits or segments, the problem is most likely in U18 on the A2A7 Controller or on one of the data latches or drivers on the A1A1 Display PCA. If the display is blank and the Controller is operational, check the various power supplies and the display blanking circuitry on the Display PCA.

Two special-function service tests are available to test the front panel indicators and keys. Press the [SPCL] [0][3] keys to check the front panel displays. The test checks the front panel displays by lighting all segments. You can abort this test by pressing any key on the Generator.

The [SPCL] [0][4] keys allow all normally open keys to be checked. As you press each key, its row and column address is displayed in the center of the FREQUENCY display field. See Table 4D-9 for the address codes for each key. Exit this test by pressing [CLR|LCL].

4D-34. SYNTHESIZER TROUBLESHOOTING

NOTE

All frequencies mentioned are synthesized; hence, they are exact (coherent with the 10-MHz reference), unless noted as approximate.

If the Generator level is inaccurate or if an unlevelled condition exists, then the A2A4 Output assembly is probably at fault. If an unlock condition exists, the problem is in the Synthesizer. If the output frequency is in error or erratic, there is likely a problem with the Synthesizer assembly. If the unlocked condition exists with REF INT/EXT set to INT, be sure no signal is applied to the 10-MHz IN/OUT connector. An external signal applied (while operating on internal reference) can cause the main loop to unlock.

MAINTENANCE
TROUBLESHOOTING AND REPAIR

Table 4D-9. Address Codes for the Front Panel Keys

KEY	CODE
[EXTAM]	1
[EXTFM]	2
[INTAM]	4
[INTFM]	5
[400/1000]	6
[FREQ]	9
[AMPL]	10
[AM]	11
[FM]	12
[SPCL]	13
[STEP]	14
[7]	15
[4]	16
[1]	17
[0]	18
[ST0]	19
[8]	20
[5]	21
[2]	22
[.]	23
[RCL]	24
[9]	25
[6]	26
[3]	27
[-]	28
[SEQ]	29
[MHz V]	30
[kHz V]	31
[Hz uV]	32
STEP[v]	33
[dB(m)]	34
[%]	35
[CLR LCL]	(Exit Test)
STEP[↑]	37
EDIT[←]	38
EDIT[↑]	40
EDIT[↓]	41
EDIT[→]	43
[STATUS]	45
RF[ON/OFF]	46

Next, check to see if the Generator frequency is stuck high or low. A good way to do this is to check the dc voltage at TP44. If it is around 2V, go to the Reference Circuitry Check in the following paragraphs.

If the voltage is around 25V, the problem is associated with the main PLL, i.e., VCO, UHF binary divider, buffer amplifier, SSB mixer, triple-modulus prescaler, or N-Divider.

Table 4D-10 shows the characteristics of the signals at the various test points on the Synthesizer PCA. The table shows the range of the signal and the expected value for a typical instrument state. The values in the TYPICAL column are for the UUT programmed to 160.11999 MHz, INT FM on at 1 kHz, and 99.9-kHz deviation.

Table 4D-10. Synthesizer PCA Test Points

TEST POINT	SIGNAL TYPE	RANGE	TYPICAL	FUNCTION
TP1	RF	245 to 522.5 MHz	480.059995 MHz; -7 dBm	All frequency digits
TP2	GROUND			
TP3	RF	245 to 522.5 MHz	480.059995 MHz; +4 dBm	All frequency digits
TP7	GROUND			
TP11	TTL	10 to 19.995 kHz	19.995 kHz	10-K, 1-K, 100-, and 10-Hz digits
TP12	TTL	1 to 1.9995 MHz	1.9995 MHz	10-K, 1-K, 100-, and 10-Hz digits
TP13	GROUND			
TP14	TTL	0.2 MHz (AL)	0.2 MHz	1-MHz and lower digits
TP15	TTL	0.01 to 1 MHz	40 kHz	
TP16	TTL	12 to 26 MHz	24 MHz	All frequency digits
TP17	RF	245 to 525 MHz	480.04 MHz; -17 dBm	All frequency digits
TP22	AUDIO	0 to 0.7V rms	0.68V rms	FM Deviation
TP23	GROUND			
TP24	TTL	20 MHz, 12.5 ns (AH)	20 MHz	
TP25	TTL	20 MHz, 12.5 ns (AH)	20 MHz	
TP26	GROUND			
TP27	TTL	10 to 19.995 MHz	19.995 MHz	10-K, 1-K, 100- and 10-Hz digits
TP31	GROUND			
TP32	AUDIO	0 to 0.8V rms	0.15V rms	FM Deviation, and Frequency
TP33	AUDIO	0 to 0.8V rms	0.15V rms	FM Deviation, and Frequency
TP34	DC	30 +/- 0.5V	30V dc	
TP35	TTL	200 kHz	200 kHz	200-kHz Reference
TP36	GROUND			
TP37	DC	-1 to -6v	-2.3V dc	Frequency
TP38	TTL	200 kHz 2.5 us(AH)	200 kHz 2.5 us	
TP39	TTL	200 kHz 10 ns (AL)	200 kHz 10 ns	
TP40	DC	2 to 22V	16.8V dc	Frequency
TP41	DC	2 to 22V	16.3V dc	Frequency
TP42	GROUND			
TP43	DC	2 to 22V	16.3V dc	Frequency
TP44	DC	2 to 22V	15.1V dc	Frequency
TP45	GROUND			
TP46	TTL	Low = unlocked high = Locked	TTL high	
TP49	TTL	10 MHz 20 ns (AL)	10 MHz, 20 ns	
TP50	TTL	10 MHz	10 MHz	
TP51	GROUND			
TP52	TTL	10 MHz 10 ns (AL)	10 MHz, 10 ns	
TP53	DC	6.0 +/- 2V 16 +/- 2v	16V dc	Above 245 MHz Below 245 MHz
TP54	TTL	10 MHz	10 MHz	
TP55	RF	800 MHz	800 MHz; -10 dBm	Below 245 MHz
TP56	INPUT			To test low- pass filters

NOTE: AH = active high
AL = active low

4D-35. Reference Circuitry Check

There should be a 10-MHz square wave at TP50. If there is no signal here, check U55 pin 10. If there is a signal at this point, the problem is in the multiplexer circuitry U55 or latch U32. If there is no signal at U55 pin 10, the problem is in the internal 10-MHz crystal oscillator. The voltage at the junction of R148 and R149 should be a TTL low (approximately 0.2V). If the voltage is a TTL high (approximately 3.8V), there is a problem with the latch, U32, or in the interface to the microprocessor. If the 10-MHz circuitry checks out, there should be a 0.2-MHz signal (20% duty cycle) at TP35.

Table 4D-11 shows the relationship between various reference frequency configurations and the control of the reference circuitry.

4D-36. Main Phase Lock Loop

If the voltage at TP44 is around 25V, connect a variable power supply to TP41. This allows the frequency of the VCO to be controlled directly. Use a spectrum analyzer or counter to monitor the Generator output.

Program the UUT to 320 MHz. If you can adjust the power supply to obtain about 320-MHz output from the VCO, the VCO and binary divider are probably OK, and you can proceed to the next paragraph in this section. If you cannot change the frequency, the problem is either the VCO, the UHF binary divider U1, or the circuitry between TP41 and TP44.

Check the signal at TP1. It should be the same as the output frequency. The level after the buffer amplifier, Q3, Q4, at TP3 (use RF test cable) should be approximately +3 dBm. The signal at TP17 should be a signal-sideband signal with the lower-sideband component (the desired signal) at about -20 dBm. If the only signal is the carrier frequency (same frequency as TP3), check the quadrature generator and the sub-synthesizer circuitry. The signal out of the triple-modulus pre-scalar should be approximately 16 MHz (with the output frequency set to approximately 320 MHz). The output of the N-Divider, TP14, should be approximately 0.2 MHz.

As the UUT frequency is programmed, the frequency at TP14 should change, since the divide ratio is being changed. If the frequency is not 0.2 MHz and/or it doesn't change, the problem is probably with the N-Divider gate array U17, divider U14, or the interface to the microprocessor.

Table 4D-11. Frequency Reference Control

INT/EXT REF	BIT				
	RMUX1H	RMUX0H	RINH	EOENL	SHENL
INT	0	0	0	0	1
EXT	1	0	1	1	1
1 = TTL High 0 = TTL Low					

If both the reference (at TP35) and the N-Divider signals at the phase detector are 0.2 MHz, the loop should lock when the operator removes the variable power supply. If the loop does not lock, check the KNV voltage at TP37. With the Signal Generator programmed to 320 MHz, TP37 should be approximately 1.0 to 2.0V. If this voltage is not correct, check the DAC U27, latches U26 and U30, and op amp U28. This voltage should also change as the operator changes the Generator frequency.

If the KN DAC appears to function, the problem is with the phase detector. Reconnect the variable power supply as before, and adjust the voltage for approximately a 0.2-MHz signal at U44 pin 3. With this frequency slightly above 0.2 MHz, TP38 should be high and TP39 should be low.

With this frequency slightly below 0.2 MHz, TP38 should be low and TP39 should be high. The only remaining circuitry is the loop amp U48 and the current source, U46, Q18, and Q19.

If the loop is locked, but the 1-MHz, 10-MHz, or 100-MHz digit cannot be programmed, the problem is either the N-divider or the interface to the microprocessor. If the 100-kHz or 10-kHz digit is inoperative or the frequency jumps as the 1-MHz digit is programmed, the problem is likely the triple-modulus prescaler. If the lower order (1-kHz, 100-Hz, 10-Hz) digits cannot be programmed, the problem is the sub-synthesizer or single-sideband mixer.

4D-37. Sub-Synthesizer and HET (800 MHz), 40-MHz Loop

The frequency at TP24 and TP25 should be 20 MHz. The frequency at U64 pins 14 and 15 should be 40 MHz. If the 40-MHz signal is present, but not the 20-MHz signal, the problem is most likely with Q4, Q5, U35, or U34. If the 40-MHz signal is in error, the problem is in the 40-MHz loop.

Check the frequency at the 40-MHz VCO, U64 pin 3. It should be 40 MHz. If it is not, lift the op-amp end of R169, and connect it to a variable power supply set to approximately 6V. The signal at U64 pin 3 should be approximately a 40-MHz ECL level (approximately 3.2V to 4.2V) signal. By varying the supply voltage, the frequency should change. A similar signal should be present at U64 pin 2. Check to see if U64 pin 11 is ECL low (approximately 3.2V).

The output of TTL buffer U65 pin 8 should be approximately 40 MHz. The output of the divide-by-4, U66, should be approximately 10 MHz. Once again, if the frequency is greater than 10 MHz, pulses should exist at TP52, and the output of op amp U60 pin 6 should be low. If the frequency is below 10 MHz, pulses should exist at TP49, and the op amp should be high (approximately 24V). The loop should lock when the operator reconnects R169.

If the TP checks are all right and the 800-MHz oscillator is not locked when in the hot band, the problem is either with the 800-MHz VCO, the divide-by-4 (U61), the divide-by-5 (U62, U63), or the logic that controls the switched +5V.

Program the UUT to 320 MHz. The frequency at TP27 (the output of the sub-synthesizer gate array U33) should be 10 MHz if the input signals are correct. The frequency at TP12 should be 1 MHz, and TP11 should be 10 kHz. There should be a 10-kHz sine wave at the hot end of R33. The signals at the output of the active quadrature generator, U10 pin 8 and U10 pin 14, should be approximately 300-mV p-p sine waves that are 90° apart in phase. Use a dual-trace oscilloscope for verification.

The frequency at TP27 should change 1000 kHz for a 1-kHz change in the programmed frequency and 100 kHz for a 100-Hz change, etc.

4D-38. FM Circuitry

The INT/EXT FM selection is done on the A2A4 Output PCA. The controls are listed in Table 4D-16.

Program the UUT to 500 MHz, INT FM, 99.9-kHz deviation, and 1-kHz modulation frequency. There should be a 2V p-p 1-kHz sine wave at TP22. Program 50-kHz deviation, and the level should drop to 1V p-p. Reprogram the deviation to 99.9 kHz. The level of the output of the KV DAC, U28 pin 7 will be approximately 1.5V p-p depending on the FM correction value (KV) in the EPROM.

The signals at TP32 and TP33 should be approximately the same, depending on how R87 is set. The output of the audio integrator should be about 1V p-p. To check the FM range, program the UUT to 9.99-kHz deviation. The ac voltage at TP32 should drop to 10% of the 99.9-kHz value. Program 500-kHz deviation, and the voltage should be five times the 99.9-kHz value.

Tables 4D-12 and 4D-13 provide FM range and FM DAC (10 bits) control information.

4D-39. LEVEL TROUBLESHOOTING

If the Generator level is inaccurate or an unlevelled condition exists, the A2A4 Output assembly or the A2A5 Attenuator/RPP assembly is probably at fault. If an unlevelled condition exists, the problem is in the circuitry ahead of the detector. Go to the paragraph in this section entitled Unlevelled Condition.

If there is no unlevelled condition, the problem is probably in the circuitry following the ALC Loop, which includes the Attenuator/RPP, the heterodyne circuit, and the output amplifier, Q215. If the level problem only exists below 245 MHz, then troubleshoot the heterodyne circuitry. If the problem is not frequency dependent and if the level is accurate above +7 dBm but inaccurate below +7 dBm, then the A2A5 Attenuator/RPP is at fault.

4D-40. OUTPUT ASSEMBLY TEST POINT SIGNAL INFORMATION

Table 4D-14 presents the nominal characteristics of the signals at the various test points on the Output PCA. The table shows the range of the signal, as well as the expected value for the Instrument Preset State [RCL] [9][8].

Table 4D-12. FM Range

FM DEVIATION (kHz)	FMRN
0 - 9.99	1
10.0 - 99.9	2
100 - 500	4

Table 4D-13. FM DAC Control

FM DEVIATION (kHz)	FM 0 - 9 (Bits)
0 - 9.99	FM Deviation / 10
10.0 - 99.9	FM Deviation / 100
100 - 500	FM Deviation / 500

Table 4D-14. Output PCA Points

TEST POINT	SIGNAL TYPE	RANGE	TYPICAL FOR RCL 98	SIGNAL DESCRIPTION
TP1	RF	245 to 1050 MHz -18 to -32 dBm	300 MHz -27 dBm	Output of mid/high bandswitch.
TP2	RF	245 to 1050 MHz -10 to -25 dBm	300 MHz -20 dBm	Output of buffer amplifier.
TP3	RF	245 to 1050 MHz -13 to -28 dBm	300 MHz -22 dBm	Output of switched low-pass filters.
TP4	RF	245 to 1050 MHz -13 to -33 dBm	300 MHz -22 dBm	Power-splitter output.
TP5	RF	800 MHz -8 dBm	No signal	Het mixer LO signal
TP6	dc+audio	-7 to 14V dc nominal	3.1V dc	Modulator control voltage.
TP7	dc+audio	0.04 to 3.0V dc nominal	1.2V dc	Leveling loop control voltage.
TP8	dc+audio	0 to 2V dc nominal	0.63V dc	Detector diode voltage.
TP9	dc+audio	400 or 1000 Hz, 0.71V rms	400 Hz 0.71V rms	Modulation Oscillator output.
TP10	Ground			
TP11	dc+audio	0 to 0.70V rms	0V	FM modulation signal to Synthesizer.

4D-41. ATTENUATOR/RPP LEVEL CONTROL

Table 4D-15 lists the Attenuator/RPP assembly A2A5 sections that are inserted in the RF output path for the various level ranges of the Generator. This information is useful in isolating a faulty section. The sections are labeled by the control line mnemonics at latch U27 on the Controller PCA. Note that the section is inserted in the RF output path when there is no power applied to the relay.

If the level problem exists above +7 dBm, the through path (0 dB attenuation) of the Attenuator may be faulty.

4D-42. Attenuator Check

Attenuator problems are most likely to be relay contact problems.

To isolate the faulty attenuator section, connect a power meter to the RF OUTPUT connector, and check the nominal levels per Table 4D-16 at both 0.4-MHz and 520-MHz frequency.

The through-path operation of the Attenuator/RPP can be roughly checked by removing the instrument and module bottom covers. Program the frequency to 1 MHz and the level to +13 dBm. Measure (with a high-impedance probe and an RF voltmeter or an oscilloscope) the level at P102 of the A2A4 Output assembly with a power meter

MAINTENANCE
TROUBLESHOOTING AND REPAIR

connected to the RF OUTPUT connector. If the voltmeter measures a nominal 1V rms, but the power meter does not read +13 dBm, then the signal is not getting through the Attenuator module, and the Attenuator/RPP is at fault.

If the level problem is subtle rather than catastrophic, a more accurate check is required to determine if the fault is the Attenuator/RPP or the Output assembly. Such a check is made by removing the Attenuator/RPP assembly, attaching an adapter (6060A-4234; P/N 744177) to the interconnect point, and making power meter measurements of the A2A4 Output assembly output. Use [SPCL] [8][2] to disable the Attenuator correction factors. The level at this point should be flat over 0.4 to 520 MHz within typically 0.2 dB and should agree with the programmed level within 2 dB.

Table 4D-15. Attenuator Level Control

AMPLITUDE RANGE IN DBM				ATTENUATOR SECTIONS INSERTED INDICATED BY X						
AM Off		AM On		A6DBL	A12DBL	A241L	A242L	A243L	A244L	A245L
7.0	19.0	1.0	9.0							
1.0	6.9	-5.0	0.9	X						
-5.0	0.9	-11.0	-5.1		X					
-11.0	-5.1	-17.0	-11.1	X	X					
-17.0	-11.1	-23.1	-17.1			X				
-23.1	-17.1	-29.1	-23.2	X		X				
-29.1	-23.2	-35.1	-29.2		X	X				
-35.1	-29.2	-41.1	-35.2	X	X	X				
-41.1	-35.2	-47.1	-41.2			X	X			
-47.1	-41.2	-53.2	-47.2	X		X	X			
-53.2	-47.2	-59.2	-53.3		X	X	X			
-59.2	-53.3	-65.2	-59.3	X	X	X	X			
-65.2	-59.3	-71.2	-65.3			X	X	X		
-71.2	-65.3	-77.2	-71.3	X		X	X	X		
-77.2	-71.3	-83.3	-77.3		X	X	X	X		
-83.3	-77.3	-89.3	-83.4	X	X	X	X	X		
-89.3	-83.4	-95.3	-89.4			X	X	X	X	
-95.3	-89.4	-101.3	-95.4	X		X	X	X	X	
-101.3	-95.4	-107.4	-101.4		X	X	X	X	X	
-107.4	-101.4	-113.4	-107.5	X	X	X	X	X	X	
-113.4	-107.5	-119.4	-113.5			X	X	X	X	X
-119.4	-113.5	-125.4	-119.5	X		X	X	X	X	X
-125.4	-119.5	-131.4	-125.5		X	X	X	X	X	X
-147.0	-125.5	-147.0	-131.5	X	X	X	X	X	X	X

Table 4D-16. Attenuator Levels

ATTENUATOR	PROG LEVEL	SPECIAL FUNCTION	OBSERVED LEVEL (NOMINAL)
6dB	+6dBm	--	+6dBm
12dB	0dBm	--	0dBm
24dB (number 1)	-12dBm	--	-12dBm
24dB (" 2)	-12dBm	83	-12dBm
24dB (" 3)	-12dBm	84	-12dBm
24dB (" 4)	-12dBm	85	-12dBm
24dB (" 5)	-12dBm	86	-12dBm

If the problem has been isolated to the Output assembly and there are no self-test errors or flashing UNCAL condition, the problem is probably in the circuits following the ALC loop. If the problem is only in the het band (frequency < 245 MHz), check the het band switch and controls, the het band circuits (mixer, filter, and amplifier), and the local oscillator signal (800 MHz, nominal -10 dBm at TP5). If the problem is at all frequencies, check the output amp, Q215, and the Het/function switch and controls.

4D-43. Unleveled Condition

If there are self-test failures and/or unleveled indications, the problem is probably in, or prior to, the ALC loop. If the problem is isolated to a specific frequency band (or bands) and other bands work properly, check signal inputs and controls to the various filters that precede the modulator. See Table 4D-7 Band, Filter, and Frequency Data for band definition. If all frequency bands are affected, the leveling ALC loop or associated controls and inputs are probably at fault.

TP6 (modulator control voltage) is a good place to monitor. With the instrument programmed to +13 dBm, the voltage on TP6 should be between +2V and +8V dc (+4V to +5V dc typical). Another place to monitor is TP7 (ALC control voltage). With the instrument programmed to +13 dBm, and the level correction disabled [SPCL][8][1], the voltage here should be approximately 1.6V dc. With the RF off, the voltage at TP7 should be 0V dc.

When the problem is isolated to a specific area, use the schematic, Theory of Operation, Test Point Chart, and normal troubleshooting techniques to isolate the fault.

4D-44. RPP Check

When checking the A2A5A2 Attenuator/RPP Control PCA, use the three dual-pin test points to aid in the troubleshooting of the assembly. The RPP can be tripped (to the protect position) by momentarily shorting the two points of TP1. It can be reset by momentarily shorting TP2. Shorting TP3 reduces the level required to trip the Attenuator/RPP, so it trips on the Generator's own output. This provides a convenient way to verify the operation of the entire trip circuitry, although at a reduced trip level.

To check the trip function with TP3 shorted, it is best to program the Generator to an output level of +10 dBm; then, program it for fixed amplitude range ([SPCL][9][1]). This allows the level to be varied from a low value up to the maximum value without any transients that might otherwise trip the RPP. Then, starting at a low level, such as -10 dBm (with the RPP reset), increase (EDIT) the UUT level in 1-dB steps until the RPP trips. RPP trip normally occurs between +10 and +15 dBm.

4D-45. AM TROUBLESHOOTING

The following paragraphs provide information that helps the operator to trace an AM problem to a specific circuit on the Output assembly.

4D-46. Internal/External AM

If an AM problem exists, determine if the problem occurs with internal AM, external AM or both. This check is done by connecting a 1V peak (2V p-p), 1-kHz signal source to the external MOD INPUT of the UUT and measuring AM depth. Use a modulation analyzer. Program the UUT to external AM and then to internal AM at 1-kHz internal modulation rate. The measured AM should agree with the programmed depth within a few percent.

Tables 4D-17 and 4D-18 provide control information for modulation and modulation-frequency selection.

Table 4D-17. Modulation ON/OFF Control

INT AM	EXT AM	INTAML	EXTAML		
Off	Off	1	1		
Off	On	1	0		
On	Off	0	1		
On	On	0	0		
INT FM	EXT FM	INTFML	EXTFML	FMENH	
Off	Off	1	1	0	
Off	On	1	0	1	
On	Off	0	1	1	
On	On	0	0	1	
1 = TTL High 0 = TTL Low					

Table 4D-18. Modulation Frequency Control

FREQUENCY	MF400L
400 Hz	0
1 kHz	1
1 = TTL High 0 = TTL Low	

If the internal AM does not agree, but the external AM is OK, the Modulation Oscillator is probably at fault. If the external AM is bad, but the internal AM is OK, then the problem is somewhere between the external MOD INPUT and the AM DAC.

If both the external and internal AM fail, the problem is probably being caused by either the modulation signal-processing circuit or the leveling loop. To determine which circuit is faulty, perform the following test.

4D-47. ALC Loop Control Voltage

PROCEDURE

1. Connect a 1V peak (2V p-p), 1-kHz signal source to the external MOD INPUT.
2. Program the UUT for 350 MHz, 7 dBm, 71% AM depth, and EXT AM ON.
3. Measure the ac and the dc voltage at TP7. The rms voltage should be nominally 50% of the dc voltage.
4. Program the UUT for 35% AM depth. The rms voltage should be nominally 25% of the dc voltage.

If the UUT fails this test, the problem lies somewhere between the EXT MOD input and TP7 (ALC loop-control voltage). To further localize the problem, the same test can be done by measuring the ac voltage at U302 pin 8 (input to level DAC). If the measured ac voltage does not change as the programmed AM depth is changed, either the AM DAC or its control is at fault. The AM DAC (A2A4U301) is an 8-bit DAC and is set to twice the programmed AM depth, e.g., 180 for 90% AM.

If the UUT passes this test, then the ALC loop control voltage is correct, and the problem is in the ALC loop. A likely cause of excessive AM depth error and harmonic distortion is detector non-linearity. The following test checks detector linearity.

4D-48. Detector Linearity

PROCEDURE

1. Install the plate covers and let the UUT warm up at room temperature for one hour.
2. Program the UUT for 350 MHz, 12 dBm, modulation OFF.
3. Program [SPCL][8][1] and [SPCL][9][1] to disable level correction and enable amplitude fixed range.
4. Measure power with a power meter at the UUT RF OUTPUT. Note the reading.
5. Program the UUT for 2 dBm using the EDIT keys. The measured power should be $10 \text{ dB} \pm 0.2 \text{ dB}$ below the reading noted in step 4.
6. Program the UUT for -8 dBm using the EDIT keys. The measured power should be $20 \text{ dB} \pm 0.4 \text{ dB}$ below the noted reading.
7. Program the UUT for [SPCL][0][0].

If the UUT fails this test, the problem is likely to be in the detector or detector-linearizer circuit. If the UUT passes the test, the problem is constrained to the other ALC loop elements, and is likely to be a bandwidth problem associated with the loop amplifier, the modulator, or the modulator-linearizer circuit.

4D-49. DEVIATION METER TROUBLESHOOTING

Set the UUT to the Meter Mode (SPCL [6][1]) at 300 MHz. Connect an external generator to the Deviation Meter Input. Program the external generator to 300 MHz, FM 500-kHz deviation, internal 1-kHz rate, and +13 dBm. The display should indicate approximately 500-kHz deviation.

Remove U3 and U4 on the Discriminator PCA, A4A1. Connect a power supply set to 10 volts to P1 pin 4. The display should indicate approximately 500 kHz. If the reading is in error, the problem is on the A/D PCA, A4A2. Replace U3 and U4.

4D-50. A/D

Continuous chip selects should appear at U2 pin 5. If the signal is inactive, the problem is on the Controller PCA, A2A7. Look for activity at U1 pin 12, U1 pin 19, and U1 pin 20. If any of these signals are inactive, replace U2 and/or U4. Look for activity at U1 pin 18. If the signal is inactive, replace U1.

4D-51. Discriminator

There should be a 1.5-MHz signal at U5 pin 4. If there is no signal present, check the mixer U6, relay K1 (and its associated control signal), and cables connecting to the meter module. There should also be a 1.5-MHz square wave at U1 pin 9. Check limiter IC U5. There should be a 1.5-MHz square wave (ECL levels) at U1 pins 14 and 15. Check limiter IC U1. Check the collectors of Q3 and Q4. There should be a 1.5-MHz trapezoidal signal from approximately 0.7 to -10.5 volts. The output of U7A pin 7 should be 0V dc. The voltage on U7B pin 1 should be between approximately ± 5 volts. Troubleshoot Q3 through Q6 and U7. The demodulated 1-kHz FM, at approximately 20 volts p-p, should appear at U2 pins 1, 7, and 14. The gates of Q1 and Q2 should be approximately -15 volts. Due to the nature of the sampling, it is not possible to measure the dc voltage at U2 pin 8. However, if the audio signal at U4 pin 3 is correct, check the peak detector U4, Q7, and U2D. There should be approximately a 1-kHz TTL signal at P1 pin 6 that controls the peak-detector sampling.

Set the UUT Meter Mode range to 50 kHz. Set the external generator to 50-kHz FM deviation. If the display does not indicate 50 kHz, check U2A, Q1 and associated circuitry. The gate voltage on Q1 should be approximately +10 volts. Set the UUT Meter Mode to - Peak. If the reading is significantly different from 50 kHz, check U2B, Q2, and associated circuitry.

Table 4D-19 Deviation Meter Control

BIT NAME	DESCRIPTION	0 VALUE	1 VALUE
POSPEAKL	Meter Peak	+ peak	- peak
RNG50KH	Meter Range	500 kHz	50 kHz
METERONH	Meter on/off	off	on
DRL	A/D Reading Ready	ready	not ready
DATAVALH	Sample Valid	not valid	valid
1 = TTL High 0 = TTL Low			

Section 5

List of Replaceable Parts

TABLE OF CONTENTS

ASSEMBLY NAME	TABLE		FIGURE	
	NO.	PAGE	NO.	PAGE
6060A/AN Final Assembly	5-1	5-4	5-1	5-5
A1 Front Section	5-2	5-7	5-2	5-7
A2 Module Section	5-3	5-8	5-3	5-8
A3 Rear Section	5-4	5-9	5-4	5-10
A1A1 Display PCA	5-5	5-11	5-5	5-12
A2A1 Synthesizer PCA	5-6	5-13	5-6	5-17
A2A2 VCO PCA	5-7	5-18	5-7	5-19
A2A4 Output PCA	5-8	5-20	5-8	5-23
A2A5 Attenuator/RPP Assembly	5-9	5-24	5-9	5-24
A2A5A4 Attenuator/RPP PCA	5-10	5-25	5-10	5-25
A2A5A5 Relay Driver/RPP PCA	5-11	5-26	5-11	5-26
A2A7 Controller PCA	5-12	5-27	5-12	5-28
A3A1 Power Supply PCA	5-13	5-29	5-13	5-30
A3A3A1 IEEE-488 Interface PCA	5-14	5-31	5-14	5-32
A4 Meter Module Assembly	5-15	5-32	5-15	5-33
A4A1 Discriminator PCA	5-16	5-34	5-16	5-35
A4A2 Analog/Digital PCA	5-17	5-36	5-17	5-36

LIST OF REPLACEABLE PARTS

5-1. INTRODUCTION

This section contains an illustrated parts breakdown of the instrument. Components are listed alphanumerically by assembly. Both electrical and mechanical components are listed by reference designation. Each listed part is shown in an accompanying illustration.

NOTE

For module exchange P/Ns, see Table 4D-1.

5-2. PARTS LIST INFORMATION

Parts lists include the following information:

1. Reference Designation
2. Description of Each Part
3. FLUKE Stock Number
4. Federal Supply Code for Manufacturers
5. Manufacturer's Part Number
6. Total Quantity of Components per Assembly
7. Recommended Quantity: This entry indicates the recommended number of spare parts necessary to support one to five instruments for a period of 2 years. This list presumes an availability of common electronic parts at the maintenance site. For maintenance for 1 year or more at an isolated site, it is recommended that at least one of each assembly in the instrument be stocked. In the case of optional subassemblies, plug-ins, etc., that are not always part of the instrument, or are deviations from the basic instrument model, the REC QTY column lists the recommended quantity of spares for the items in that particular assembly.

5-3. HOW TO OBTAIN PARTS

Components may be ordered directly from the manufacturer's part number, or from the John Fluke Mfg. Co., Inc. or an authorized representative, by using the FLUKE STOCK NUMBER. In the event the part ordered has been replaced by a new or improved part, the replacement will be accompanied by an explanatory note and installation instructions, if necessary.

To ensure prompt and efficient handling of your order, include the following information:

1. Quantity
2. FLUKE Stock Number
3. Description
4. Reference Designation
5. Printed Circuit Board Part Number and Revision Letter
6. Instrument Model and Serial number

5-4. RECOMMENDED SPARE PARTS KIT

A Recommended Spare Parts Kit for your basic instrument is available from the factory. This kit contains those items listed in the REC QTY column of the parts lists in the quantities recommended.

Parts price information is available from the John Fluke Mfg. Co., Inc., or its representative. Prices are also available through the Fluke Replacement Parts Catalog, which is available upon request.

CAUTION

*

Indicated devices are subject to damage by static discharge.

LIST OF REPLACEABLE PARTS

TABLE 5-1. 6060A/AN FINAL ASSEMBLY
(SEE FIGURE 5-1.)

REFERENCE DESIGNATOR	DESCRIPTION	FLUKE STOCK	MFRS SPLY CODE	MANUFACTURERS PART NUMBER OR GENERIC TYPE	TOT QTY	R S T	N O T
A->NUMERIC-->	S-----	--NO--	--	--OR--		-Q-	-E-
A 1	FRONT SECTION				1		
A 2	MODULE SECTION				1		
A 3	REAR SECTION				1		
H 1	SCREW, MACH, PHUP, S. STL, 6-32X1/4	320093	89536	320093	20		
H 2	SCREW, MACH, PHF, SEMS, STL, 6-32X1/2	177030	89536	177030	4		
H 3	SCREW, MACH, PHF, STL, 10-32X1/4	218941	89536	218941	18		
H 4	SCREW, MACH, PHF, S. STL, 6-32X3/8	334458	89536	334458	78		
H 6	SCREW, MACH, PHF, MAG S- STL, 6-32X9/32	772236	89536	772236	1		
H 7	WASHER, FLAT, STEEL, #6, 0.031 THK	110270	89536	110270	1		
H 8	SCREW, MACH, PHF 8-32X3/8	436030	89536	436030	4		
H 9	SCREW, MACH, PHF 6-32X1/4	178533	89536	178533	6		
H 10	SCREW, MACH, PHF 4-40X1/4	185918	89536	185918	2		
H 11	SCREW, MACH, PHF 6-32X1-3/8	114926	89536	114926	4		
H 12	SCREW, MACH, PHF 6-32X7/8	114868	89536	114868	3		
H 13	SCREW, MACH, PHF 8-32X3/8	114116	89536	114116	20		
H 14	WASHER, LOCK, INTRNL, STEEL #6	110330	89536	110330	4		
H 15	NUT, MACH, HEX, STL, 4-40	184044	89536	184044	2		
H 16	WASHER, LOCK, INTRNL, STEEL #4	110403	89536	110403	2		
H 17	SCREW, MACH, PHF 4-40X3/8	281196	89536	281196	2		
H 18	SCREW, MACH, PHF, 6-32X1/4	152140	89536	152140	3		
MP 1	TOP COVER	704864	89536	704864	1		
MP 2	BOTTOM COVER	704874	89536	704874	1		
MP 3	FOOT, SINGLE BAIL TYPE (DARK UMBER)	653923	89536	653923	4		
MP 4	NAMEPLATE, SERIAL -REAR PANEL-	472795	89536	472795	1		
MP 5	DECAL, FRONT CORNER	659227	89536	659227	2		
MP 6	SIDE TRIM 18"	525998	89536	525998	2		
MP 7	DECAL, REAR CORNER	685214	89536	685214	2		
MP 8	COVER, OUTPUT, PLATED	731430	89536	731430	1		
MP 9	COVER, SYNTHESIZER, PLATED	774372	89536	774372	1		
MP 10	COVER, METER MODULE, PLATED	774398	89536	774398	1		
MP 11	GASKET, SHIELDING, MONEL MESH	520320	89536	520320	5		
MP 12	SHIPPING BOX	752758	89536	752758	1		
MP 13	SHIPPING END CAPS	752766	89536	752766	2		
MP 14	CAP, ACC, COAX, BNC	478982	89536	478982	1		
MP 15	DESICCANT	309690	89536	309690	1		
MP 16	CHASSIS SIDE	657627	89536	657627	2		
MP 17	CABLE TIE	407908	89536	407908	2		
MP 18	CABLE CLAMP	103796	89536	103796	1		
MP 19	CABLE TIE, 4"	172080	89536	172080	9		
MP 20	CABLE, ETHYL CELLULOSE	101345	89536	101345	1		
MP 21	BRACKET, POWER SWITCH	774489	89536	774489	1		
MP 22	PUSHBUTTON, LG RECT. GREEN CL	420893	89536	420893	1		
MP 23	COVER PLATE, IEEE	774075	89536	774075	1		
MP 24	IEEE MTG BRKT	657650	89536	657650	1		
TM 1	INSTRUCTION MANUAL, 6060A/AN	755421	89536	755421	2		
U 1	IC, NHOS, GP1B TALKER/LISTENER/CNTRLR	773143	89536	773143	1		
U 23, 24	* IC, 2K X 8 EPROM	454603	01295	TM32516JL	2		
W 1	CABLE, SEMI-RIGID, W1 (DISCR/TYPE-N)	774356	89536	774356	1		
W 2	CABLE ASSEMBLY, CONTROLLER-POWER	738534	89536	738534	1		
W 3	CORD, LINE, S-15/IEC, (NOT SHOWN)	284174	89536	284174	1		
W 17	CABLE, SEMI-RIGID, W17 (ATTEN/DISCR)	774349	89536	774349	1		

U23, U24 UNPROGRAMMED PART

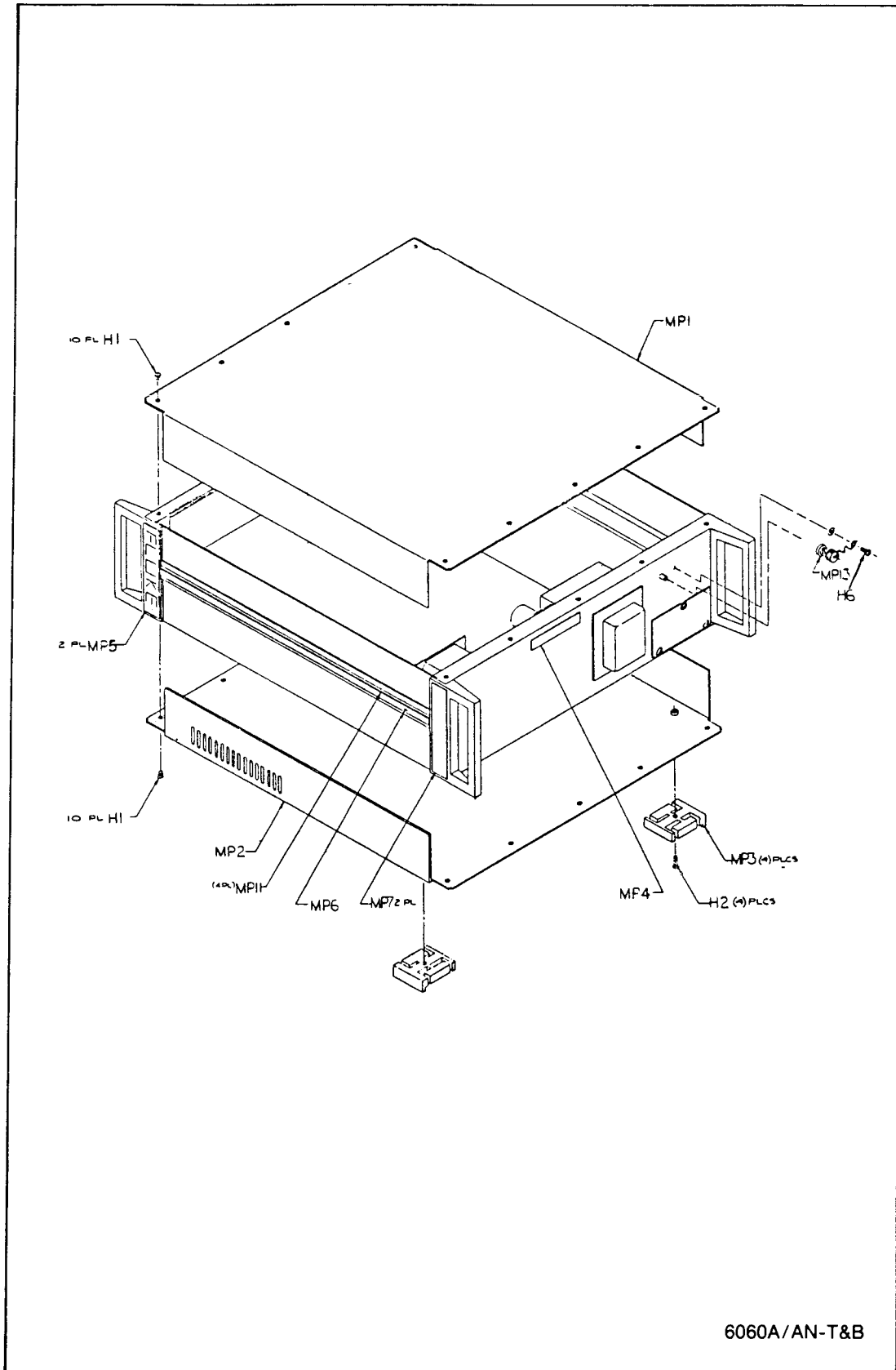

6060A/AN-T&B

Figure 5-1. 6060A/AN Final Assembly

LIST OF REPLACEABLE PARTS

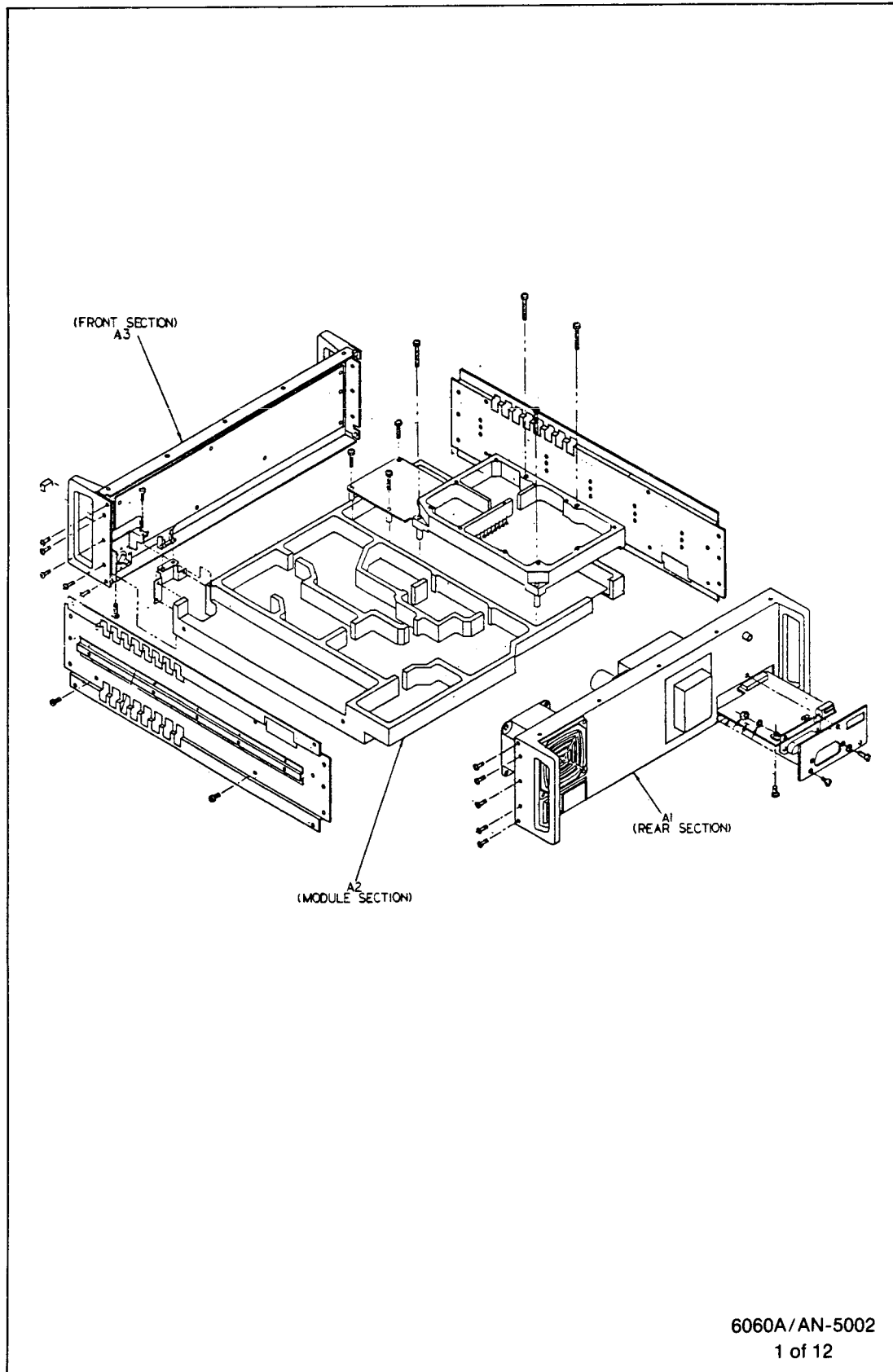
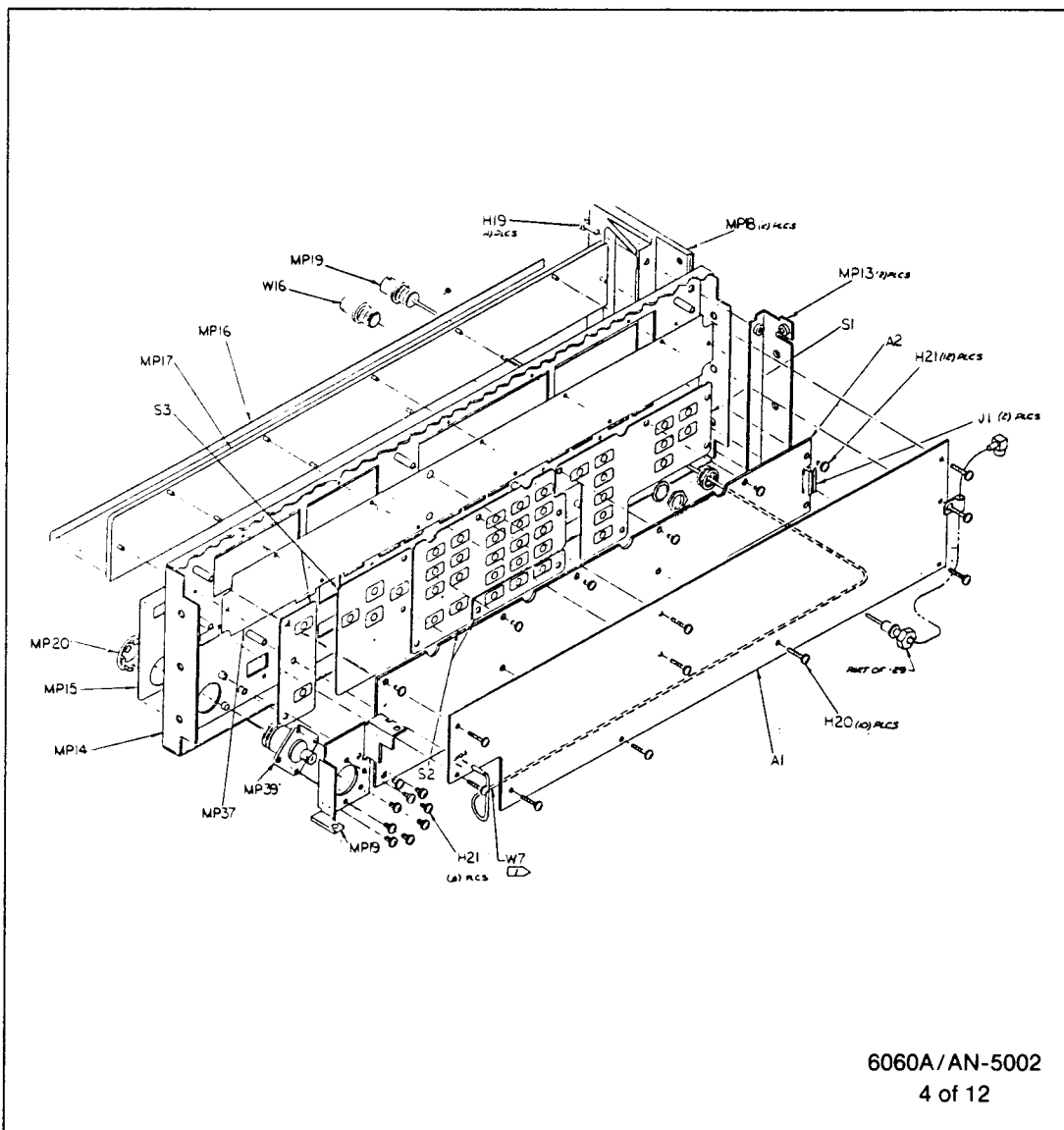

Figure 5-1. 6060A/AN Final Assembly (cont)

LIST OF REPLACEABLE PARTS

TABLE 5-2. A1 FRONT SECTION
(SEE FIGURE 5-2.)

REFERENCE DESIGNATOR	QUANTITY	DESCRIPTION	FIGURE STOCK NO.	MFRS SPLY CODE	MANUFACTURERS PART NUMBER OR GENERIC TYPE	TOT QTY	R S T	N O E
A	1	DISPLAY PCA	492074	89536	492074	1		
A	2	SWITCH FWB	657775	89536	657775	1		
H	19	SCREW, LAF, SCKT, STL, B, 30X3/8	295105	89536	295105	4		
H	20	SCREW, MALD, FHP, SEMS, STL, 4-40X1/2	353060	89536	353060	10		
H	21	SCREW, MALD, FHP, SEMS, STL, 4-40X3/16	732750	89536	732750	20		
J	1	SOCKET, 1 ROW, FWB, 0.1000 IN, 7 PIN	520809	30035	55-109 1-07	2		
MP	13	CORNER BRACKET	657601	89536	657601	2		
MP	14	FRONT PANEL SM	657593	89536	657593	1		
MP	15	DECAL, FRONT PANEL	774323	89536	774323	1		
MP	16	DECAL, LENS	774331	89536	774331	1		
MP	17	LENS DISPLAY	657718	89536	657718	1		
MP	18	CORNER HANDLE, FRONT 0.25 INCH	656173	89536	656173	2		
MP	19	BRACKET, REF OUTPUT, PLATED	774471	89536	774471	1		
MP	20	BUSHING INSULATION REF OUTPUT	537803	89536	537803	1		
MP	37	SHIELD, DISPLAY	731257	89536	731257	1		
MP	39	ADaptor, COAX, SMA(M), (NOM)	516963	89536	516963	1		
MP	40	CLAMP	101345	89536	101345	1		
S	1	SWITCH, LEFT CONDUCTIVE ELASTOMERIC	698597	89536	698597	1		
S	2	SWITCH, CENTER CONDUCTIVE ELASTOMERIC	731349	89536	731349	1		
S	3	SWITCH, RIGHT CONDUCTIVE ELASTOMERIC	731356	89536	731356	1		
W	7	CABLE ASSY MOD INPUT FRONT	738500	89536	738500	1		
W	16	CABLE ASSY, METER INPUT W/6 R/108-BNC	774273	89536	774273	1		



6060A/AN-5002
4 of 12

Figure 5-2. A1 Front Section

LIST OF REPLACEABLE PARTS

TABLE 5-3. A2 MODULE SECTION
(SEE FIGURE 5-3)

REFERENCE DESIGNATOR	DESCRIPTION	STOCK NUMBER	QTY	MANUFACTURER PART NUMBER OR GENERAL TYPE	QTY	UNIT
A 1	* SYNTHESIZER PCA	774208	1	89536 774208	1	
A 2	* MAIN VCU (CLOCK) PCA	752311	1	89536 752311	1	
A 4	* OUTPUT PCA	774216	1	89536 774216	1	
A 5	* ATTENUATOR/RFP ASSEMBLY	752667	1	89536 752667	1	
A 7	* CONTROLLER PCA	774224	1	89536 774224	1	
C 1	CAP. CER. 1000PF. ± 52.50V CUG	528539	1	51406 RFL113	1	
H 11	SCREW, MACH. FHP. STMS. STL. 6-32X1/4	178533	3	89536 178533	3	
H 12	WASHER, FLAT, STEEL, #6, 0.031 THK	110270	4	89536 110270	4	
H 13	SCREW, MACH. FHP. MAG. S. STL. 6-32X9/32	772236	83	89536 772236	83	
H 14	SCREW, MACH. FHP. STL. 10-32X1.4	218941	3	89536 218941	3	
H 16	SCREW, MACH. FHP. STMS. STL. 6-32X5/16	536787	4	89536 536787	4	
H 18	NUT, CAP. EXT. LOCK, STL. 10-32	559237	1	89536 559237	1	
MF 9	AIDE, PCB. THT	541730	9	89536 541730	9	
MF 10	GASKET, SHIELDING, MURTEL MESH, CIRCULAR	720664	11	89536 720664	11	
MF 11	CABLE TIE, ANCHOR, ADHESV. 0.125" DIA	407908	1	89536 407908	1	
MF 12	CABLE TIE, 4" L. 0.100" W. 0.2" DIA	172080	1	89536 172080	1	
W 6	CABLE ASSY. MOD. 10PH. MODUL	738542	1	89536 738542	1	
W 10	CABLE ASSEMBLY, SYNTHESIZER POWER	738526	1	89536 738526	1	

NOTE 1= ASSEMBLY INCLUDES ASSOCIATED CALIBRATED EPROM

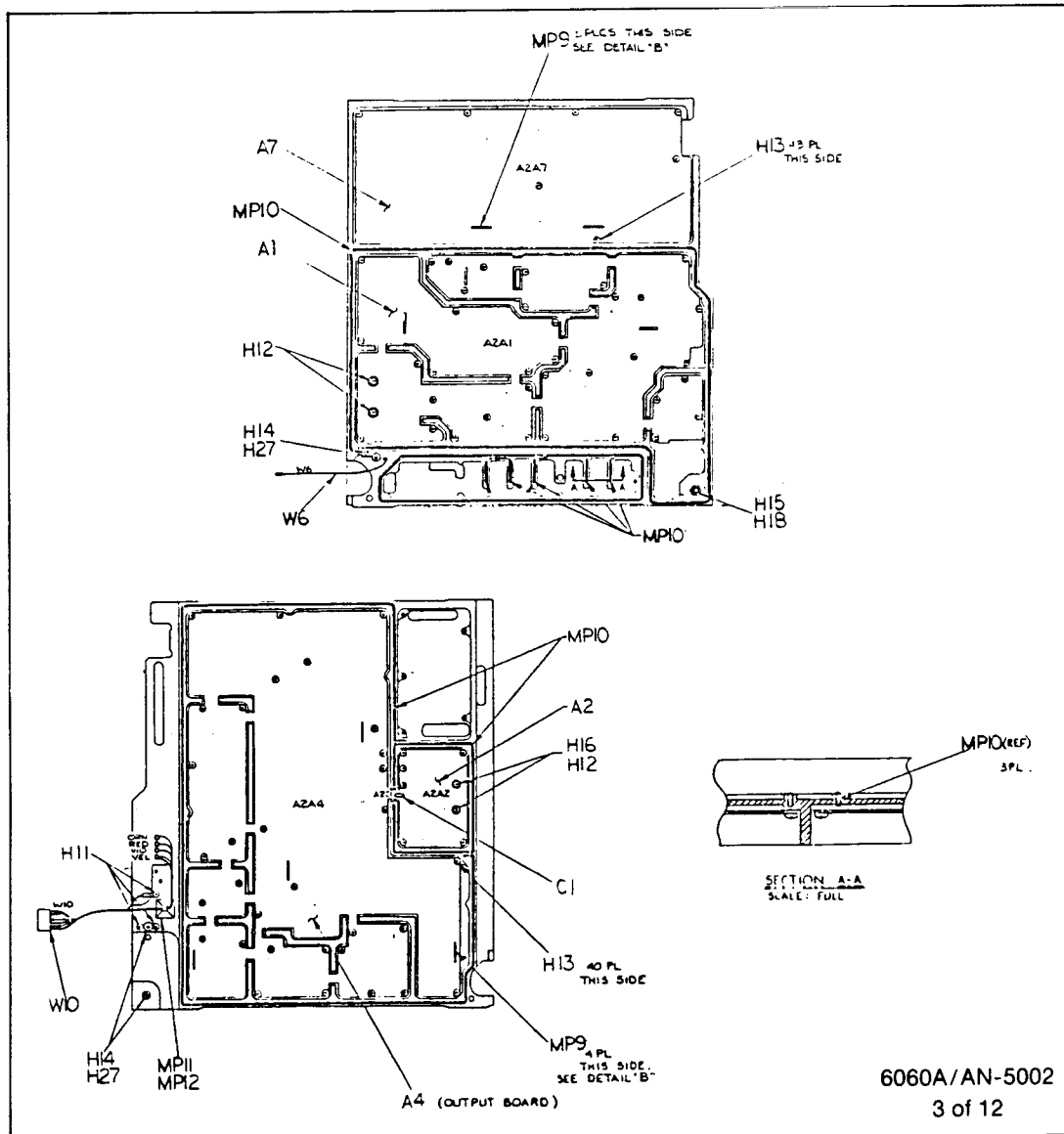

Figure 5-3. A2 Module Section

LIST OF REPLACEABLE PARTS

TABLE 5-4. A3 REAR SECTION
(SEE FIGURE 5-4.)

REFERENCE DESIGNATOR A - NUMERICS	S	DESCRIPTION	FLUKE STOCK NO.	MFRS SFLY CODE	MANUFACTURERS PART NUMBER OR GENERIC TYPE	TOT QTY	R S T	U E
A	1	POWER SUPPLY PCA	657825	89536	657825	1		
B	1	FAN, 12VDC, 34CFM, 3.15" SQ	706598	89536	706598	1		
E	1, 2	SOLDER LUG, #6	132399	78189	2104-06-00	2		
F	1	FUSE, 1/4 X 1-1/4, FAST, 1.5A, 250V	109330	71400	AGC1-1/2	1		
FL	2	FILTER, LINE, PART, PCB 115V	773119	89536	773119	1		
H	22	NUT, ELAST. STOP, HEX, STL, 8-32	306308	89536	306308	4		
H	24	SCREW, CAP, SCKT, STL, 8-32X3/8	295105	89536	295105	4		
H	25	WASHER, SHLDR, NYLON, #3	485417	89536	485417	4		
H	26	NUT, LOCK, S, STL, 4-40	558866	89536	558866	4		
H	27	SCREW, MACH, PHF, SEMS, STL, 6-32X5/8	272591	89536	272591	2		
H	28	SCREW, MACH, STL, PHF, 8-32X2-1/2	772376	89536	772376	4		
H	29	WASHER, FLAT, S STEEL, #8, 0.032 THK	176743	86928	5710-31-32	8		
H	30	WASHER, FLAT, FIBER, #8, 0.063 THK	110353	73734	1472	4		
H	32	SCREW, MACH, PHF, SEMS, STL, 6-32X1/4	178533	89536	178533	5		
H	33	WASHER, SPRING, STL, 0.138X0.281X0.020	571968	89536	571968	2		
H	34	WASHER, SHLDR, FIBER, #6	110387	86928	5604-47	6		
H	35	NUT, ELAST. STOP, HEX, STL, 6-32	110841	89536	110841	3		
H	36	WASHER, FLAT, ALUM, 0.125 ID, 0.062 THK	381749	89536	381749	4		
H	37	SCREW	615369	89536	615369	4		
H	38	WASHER	110338	89536	110338	4		
MP	21	PANEL, REAR	774067	89536	774067	1		
MP	22	CORNER BRACKET	657601	89536	657601	2		
MP	23	CORNER HANDLE, FRONT 5.25 INCH	656173	89536	656173	2		
MP	24	INSUL PART, TRANS, SILICONE, POWER	534453	89536	534453	4		
MP	25	INSUL PART, TRANS, SILICONE, TO-3	473165	55285	7403-08 FR-05	1	1	
MP	26	SLEEVE, FULYOL, SHRINK, .187-.093 ID, BLACK	113852	89536	113852	1		
MP	27	TRANSFORMER COVER, PAINTED	731307	89536	731307	1		
MP	28	CABLE TIE, 4"L, 0.100"W, 0.75 DIA	172080	89536	172080	2		
MP	29	CABLE, ETHYL CELLULOSE, TYPE 1/2-6R	100974	89536	100974	2		
MP	30	CABLE TIE, ANCHOR, ADHSV, 0.122" TIE	407908	89536	407908	2		
MP	38	HEAT DIS, TRANSISTOR, SNGL 103, ALUM	740738	89536	740738	1		
T	1	TRANSFORMER, POWER	774315	89536	774315	1		
U	1	IC, VOLT REG, FIXED, +15 VOLTS, 1.5 AMPS	413187	04713	MC7815CT	1	1	2
U	1	IC, VOLT REG, FIXED, +5 VOLTS, 3 AMP, TO-3	453944	12040	LM223K	1		1
U	2	IC, VOLT REG, FIXED, -15 VOLTS, 1.5 AMPS	413179	04713	MC7915CP	1	1	2
U	4	IC, VOLT REG, ADJ, 1.2 TO 37 V, 1.5 AMPS	460410	12040	LH317T	1		
U	5	IC, BIPOLAR	772830	89536	772830	1		
W	1	WIRE, PVC, C, 22AWG, BTIN, BLK	115717	89536	115717	1		
W	2	WIRE, PVC, C, 22AWG, BTIN, YEL	115758	89536	115758	1		
W	3	WIRE, PVC, C, 22AWG, BTIN, LT GRN	135483	89536	135483	1		
W	6	CABLE ASSY, RF, REF IN/OUT	748681	89536	748681	1		
W	15	HARNESS, LINE FILTER	792698	89536	792698	1		

NOTE 1= REFERED TO THROUGHOUT THE MANUAL AS A3U1

NOTE 2= PART OF A3A1

LIST OF REPLACEABLE PARTS

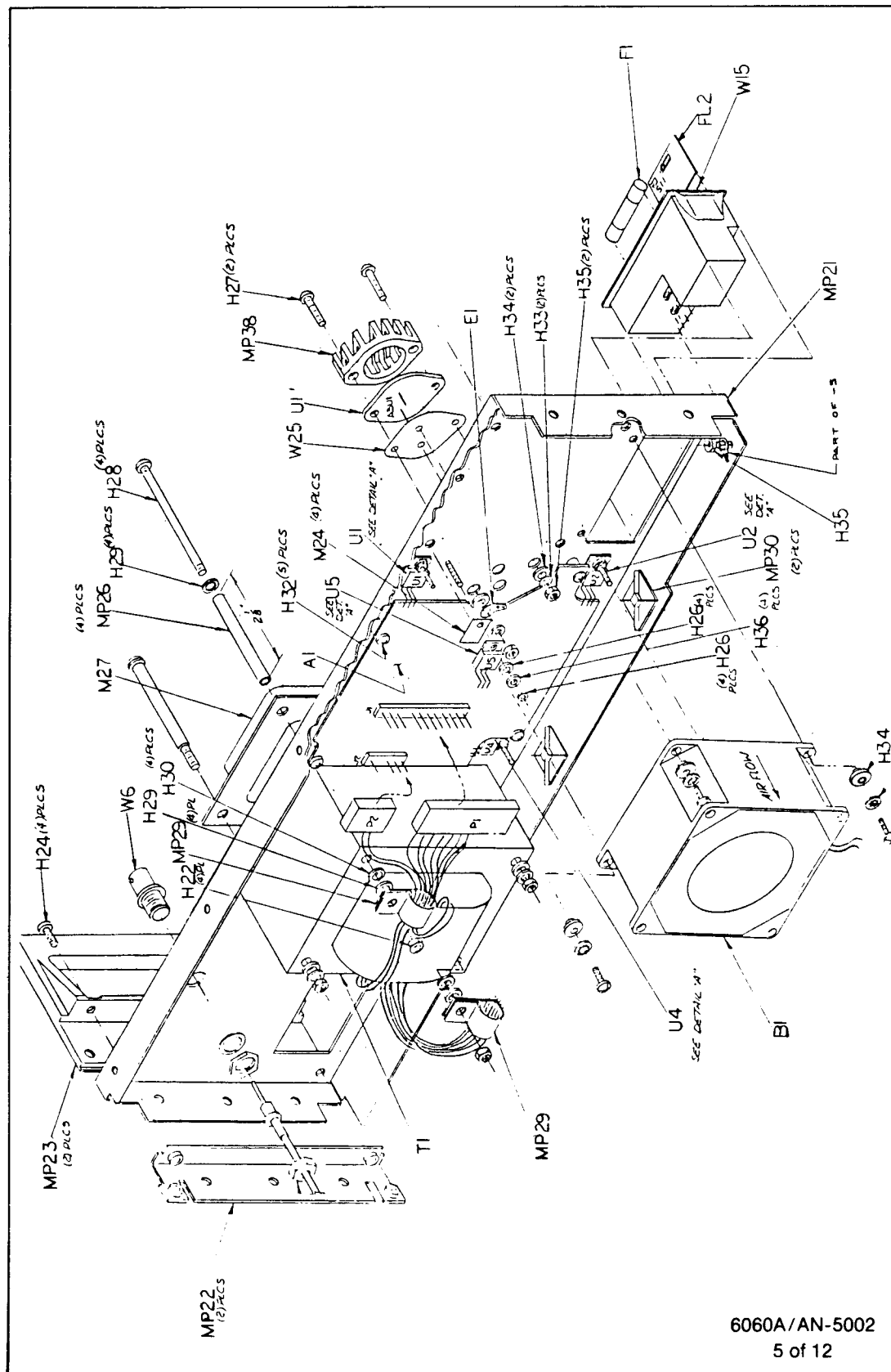

6060A/AN-5002
5 of 12

Figure 5-4. A3 Rear Section

LIST OF REPLACEABLE PARTS

TABLE 5-5. A1A1 DISPLAY FLA
(SEE FIGURE 5-5.)

REFERENCE DESIGNATOR	QUANTITY	DESCRIPTION	FLUORE STOCK NO.	MFRS SPLY CODE	MANUFACTURERS PART NUMBER OR GENERIC TYPE	TOTL QTY	R S Q	N O T E
C 1		CAP, TA, 4.7UF, +20%, 50V	363721	56289	196D475X9015HA1	1		
C 2, 27, 28,		CAP, TA, 10UF, +20%, 10V	176214	56289	196D106X0010KA1	4		
C 30			176214					
C 3, 18		CAP, POLYEST, 0.1UF, +10%, 50V	696484	89536	696484	16		
C 23, 24		CAP, TA, 10UF, +20%, 20V	350662	56289	196D106X0020KA1	2		
C 25, 26		CAP, TA, 3UF, +20%, 6V	163915	56289	196D394X0020KA1	2		
C 29		CAP, CER, 0.001UF, +20%, 100V, X7K	402966	72982	8121-A100-W5K-102M	1		
DS 1		DISPLAY VACUUM FLUORESCENT FREQUENCY	698456	89536	698456	1		
DS 2		DISPLAY VACUUM FLUORESCENT AMPLITUDE	698464	89536	698464	1	1	
J 101		PIN, SINGLE, PWB, 0.025 SQ	267500	00779	87022-1	14		
J 103		PIN, SINGLE, PWB, 0.05H DIA	233411	00779	60599-3	2		
R 1, 2		RES, CF, 100K, +5%, 0.25W	348920	80031	CR251-4-5F100K	2		
R 3		RES, CF, 620, +5%, 0.25W	442319	80031	CR251-4-5F620E	1		
R 4		RES, MF, 9.09K, +1%, 0.125W, 100PPM	221663	91637	CHF559091F	1		
R 5		RES, MF, 31.6K, +1%, 0.125W, 100PPM	261610	91637	CHF553162F	1		
R 6		RES, MF, 8.06K, +1%, 0.125W, 100PPM	294942	91637	CHF558061F	1		
R 7		RES, MF, 2K, +1%, 0.125W, 100PPM	235226	91637	CHF552001F	1		
R 8		RES, MF, 48.7K, +1%, 0.125W, 100PPM	267385	89536	267385	1		
R 9, 10		RES, CF, 30K, +5%, 0.25W	368753	80031	CR251-4-5F30K	2		
R 11, 14		RES, CC, 10K, +10%, 0.125W	246975	01121	BB1031	4		
R 15		RES, CC, 560, +10%, 0.125W	115303	89536	115303	1		
R 16		RES, VAR, CER, 5K, +10%, 0.5W	288282	75378	360T052A2	1		
TP 1		TERM, FASTON, TAB, SOLDER, 0.110 WIDE	512889	02660	62395	1		
U 1, 5		* IC, LSTTL, OCTAL D FZF, +EDW TRG, W/CLEAR	454892	01295	SN74LS273N	5	1	
U 6, 10		* IC, BIPLR, BCHNL FLUORESCNT DISPLY DRVR	535799	56289	UDN6118A	5		
U 11, 17		* IC, LSTTL, RETRG MONOSTAB MULTIVR W/CLR	404186	01295	SN74LS123N	2	1	
U 12		* IC, LSTTL, DUAL 4 INPUT AND GATE	408708	01295	SN74LS21N	1	1	
U 13, 15		* IC, TTL, HEX INVERTER W/OPEN COLLECTOR	288605	01295	SN7416N	2	1	
U 14		* IC, LSTTL, HEX BUFFER W/NOR ENABLE	483800	01295	SN74LS367N	1	1	
U 16		* IC, COMPARATOR, DUAL, LO-PWR, B PIN DIP	478354	12040	LM393N	1	1	
U 18		* IC, 1.22V, 25 PPM I.C., BANDGAP REF	634154	32293	ITS6935-2	1		
W 8		CABLE ASSEMBLY, CONTROLLER-DISPLAY	738476	89536	738476	1		
Z 1		RES, NET, SIF, 10 PIN, 9 RES, 100K, +2%	461038	80031	95081002CL	1		
Z 2		RES, NET, SIF, 10 PIN, 9 RES, 10K, +2%	414003	80031	95081002CL	1		

LIST OF REPLACEABLE PARTS

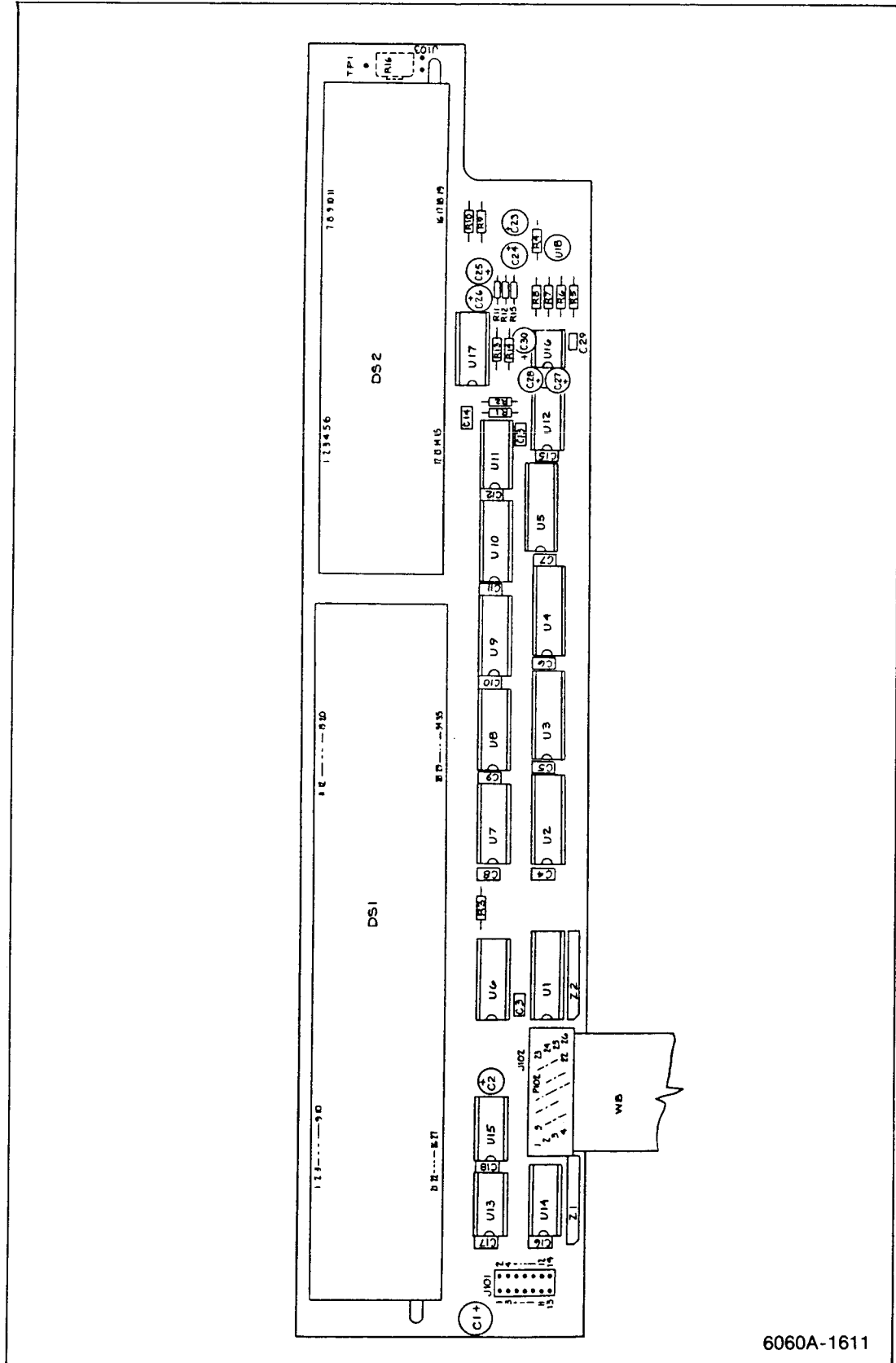

6060A-1611

Figure 5-5. A1A1 Display PCA

LIST OF REPLACEABLE PARTS

TABLE 5-6. A2A1 SYNTHESIZER PCA
(SEE FIGURE 5-6).

REFERENCE DESIGNATOR	DESCRIPTION	FLUKE STOCK NUMBER	MFRS SFLY CODE	MANUFACTURERS PART NUMBER OR GENERIC TYPE	QTY	R	S	T	N	O	D
C 1, 2	CAP, CLK, 2.7PF, +/-0.25PF, 100V, CUJ	363705	89536	363705	2						
C 3, 4, 62, 98, 100, 181, 182, 185, 186, 189, 190, 193, 196, 198, 199, 215, 236	CAP, CER, 0.001UF, +/-20%, 100V, X7R	402966	72982	8121-A100-W5R-102M	17						
C 5, 7, 10, 13, 20, 39, 40, 43, 52, 53, 205, 231-234	CAP, CER, 470PF, +/-20%, 100V, X7R	358275	72982	8111-A100-W5R-471M	17						
C 8, 21, 9, 15, 18, 26, 28, 64, 89, 137, 146	CAP, CER, 6.8PF, +/-0.25PF, 100V, CUJ	512327	89536	512327	2						
C 14, 27, 31, 36, 55, 59, 61, 63, 65, 69, 70, 72, 74, 76, 81, 83, 84, 87, 88, 101, 106, 108, 110, 112, 120, 122, 132, 133, 135, 138, 140-145, 157, 165, 167-169, 174, 175, 180, 184, 188, 191, 192, 194, 195, 200	CAP, CER, 100PF, +/-2%, 100V, COG	512848	51406	RFE121	9						
C 16, 17, 19, 25, 29, 38, 201, 202, 30, 37, 49, 118, 32, 33, 34, 35, 41, 42, 48, 51, 113, 114, 54, 71, 91, 127, 166, 58, 82, 107, 150, 75, 85, 86, 95, 155, 156, 92, 94, 128, 99, 109, 111, 115, 116, 117, 119, 121, 123, 124, 125, 126, 129, 130, 131, 134, 136, 235, 139, 151, 152, 210, 211, 214, 216, 218, 224-226, 228, 230, 153, 154, 171, 173, 208, 209, 176, 177, 178, 179, 183, 187, 197, 219, 227, 240, 204, 206, 207, 212, 222, 213, 223, 217, 220, 221, 237, VR 2, CR 5-8, 17, CR 18, 21, CR 9, 10, 12-	CAP, POLYEST, 0.1UF, +/-20%, 50V	732883	89536	732883	68						
	CAP, CER, 12PF, +/-2%, 100V, COG	376871	89536	376871	2						
	CAP, CER, 4.7PF, +/-0.25PF, 100V, CUJ	362772	89536	362772	1						
	CAP, CER, 10PF, +/-5%, 50V, COG	494781	89536	494781	1						
	CAP, CER, 47PF, +/-2%, 100V, COG	512368	89536	512368	4						
	CAP, CER, 0.22UF, +/-20%, 50V, Z5U	519157	51406	RFE11Z5U224H50V	4						
	CAP, POLYEST, 470PF, +/-1%, 63V	528356	12954	B31063/470/1/63	1						
	CAP, POLYEST, 100PF, +/-1%, 63V	528372	12954	B31063/100/1/63	1						
	CAP, POLYEST, 330PF, +/-1%, 63V	528364	12954	B31063/330/1/63	1						
	CAP, POLYEST, 1000PF, +/-1%, 63V	528380	12954	B31063/1000/1/63	1						
	CAP, POLYEST, 0.1UF, +/-10%, 50V	696484	89536	696484	2						
	CAP, POLYEST, 0.033UF, +/-10%, 50V	696476	89536	696476	1						
	CAP, POLYEST, 0.22UF, +/-10%, 50V	696492	89536	696492	3						
	CAP, TA, 10UF, +/-20%, 10V	176214	56289	196D106X0010XA1	5						
	CAP, TA, 39UF, +/-20%, 6V	163915	56289	196D394X0020KA1	4						
	CAP, CER, 22PF, +/-2%, 100V, COG	512871	89536	512871	6						
	CAP, TA, 10UF, +/-20%, 35V	417683	56289	196D106X0035KA1	4						
	CAP, POLYEST, 0.0075UF, 2%, 100V	484121	89536	484121	1						
	CAP, TA, 15UF, +/-20%, 20V	519686	56289	196D156X0020KE4	2						
	CAP, FOLYFR, 0.0786UF, +/-1%, 50V	422998	89536	422998	1						
	CAP, TA, 3.3UF, +/-20%, 20V	436071	01884	196D335X0020KA1	2						
	CAP, CER, 1000PF, +/-5%, 50V, COG	528539	51406	RFE113	2						
	CAP, POLYEST, 0.022UF, +/-5%, 100V	484147	89536	484147	1						
	CAP, POLYEST, 0.056UF, +/-5%, 100V	284877	89536	284877	1						
	CAP, POLYEST, 0.027UF, +/-5%, 100V	484154	89536	484154	1						
	CAP, POLYEST, 0.0015UF, +/-2%, 100V	484113	89536	484113	1						
	CAP, TA, 82UF, +/-20%, 20V	357392	12954	D82G52D20M	2						
	CAP, POLYCA, 5UF, +/-10%, 50V	313254	84411	X463UW5.0UF-10P-50	1						
	CAP, TA, 15UF, +/-20%, 6V	161935	56289	196D156X0006-KA1	1						
	CAP, TA, 1UF, +/-10%, 35V	161919	56289	196D010X0035L	2						
	CAP, CER, 560PF, +/-5%, 50V, COG	528505	89536	528505	1						
	CAP, CER, 1800PF, +/-2%, 50V, T2J	528547	89536	528547	1						
	CAP, CER, 180PF, +/-5%, 100V, COG	603506	56289	C023B501E181M	11						
		603506									
		603506									
	CAP, VAR, 1 TO 10PF, 250V, AIR	733212	89536	733212	1						
	CAP, CER, 1.8PF	512897	89536	512897	1						
	CAP, CER, 27PF, +/-2%, 100V, COG	362749	51406	RFE121	1						
	CAP, AL, 220UF, +/-20%, 16V	435990	57640	SM/VR	3						
	CAP, POLYEST, 0.27UF, +/-10%, 50V	733576	89536	733576	1						
	CAP, POLYEST, 0.15UF, +/-10%, 50V	682955	89536	682955	1						
	CAP, TA, 6.8UF, +/-20%, 35V	363713	56289	196D685X0035KA1	1						
	CAP, CER, 2200PF, +/-20%, 100V, X7R	358291	89536	358291	1						
	CAP, POLYEST, 0.47UF, +/-10%, 50V	714725	89536	714725	2						
	CAP, CER, 10PF, +/-2%, 100V, COG	512343	89536	512343	4						
	CAP, CER, 330PF, +/-5%, 100V, COG	528620	51406	RFE121	1						
	CAP, VAR, 0.8-10PF, 250V, AIR	229930	91293	5201	1						
	CAP, POLYEST, 0.082UF, +/-10%, 50V	714717	89536	714717	1						
	CAP, CER, 1000PF, +/-10%, 50V, X7R	484378	89536	484378	2						
	CAP, CER, 6.8PF, +/-0.5PF, 50V, COG	479196	89536	479196	2						
	CAP, CER, 4.3PF, +/-0.5PF, 50V, COG	514216	89536	514216	1						
	CAP, CER, 3.9PF, +/-0.25PF, 100V, CUJ	512947	89536	512947	1						
	CAP, AL, 470UF, +/-20%, 16V	772855	89536	772855	1						
	CAP, POLYEST, 2200PF, +/-10%, 50V	780536	89536	780536	1						
	* ZENER, COMP, 6.4V, 3%, 1 FEM TC, 2.0MA	357848	04713	SZG2011B	1						2
	* DIODE, SI, BV= 75.0V, IO=150MA, 500 MW	203323	07910-	1N4448	7						1
		203323									
	* DIODE, SI, SCHOTTKY BARRIER, SMALL SIGNAL	313247	28484	HF5082-6264	8						2

LIST OF REPLACEABLE PARTS

TABLE 5-6. A2A1 SYNTHESIZER PCA
(SEE FIGURE 5-6).

REFERENCE DESIGNATOR A (NUMERICS)	DESCRIPTION	FIGURE STOCK NO.	PKTS SPLY CODE	MANUFACTURERS PART NUMBER OR GENERIC TYPE	QTY	R	U
CR 15, 28, 29	* ZENER, UNCOMP., 10.0V, 10%, 12.5MA, 0.4W	313247					
CR 11	* ZENER, UNCOMP., 8.2V, 5%, 20.0MA, 0.4W	113324	07910	1N931A	1	1	
CR 16	* DIODE, ST, VARACTOR, FIV- 30V, HYPER ABRU	386771	04713	1N756A	1	1	
CR 24, 26, 27	* DIODE, ST, VARACTOR, FIV- 30V, HYPER ABRU	722140	89536	722140	3	1	
J	SOCKET, SINGLE, FWR, FOR 0.030-0.035 PIN	392944	00779	3-332670-0	16		
J 112	CONN, COAX, SMB(M), FWR OR PANEL	512095	16733	707033	1		
L 1, 18, 21,	CHOKES, 6TURN	320911	89536	320911	10		
L 23, 29- 32,		320911					
L 34, 65		320911					
L 2, 3, 71,	INDUCTOR, 0.10 UH, +/-10%, 400MHZ, SHI DED	257154	24759	MR0R10	4		
L 72		257154					
L 4, 19, 20,	INDUCTOR, 0.68 UH, +/-10%, 221MHZ, SHI DED	320937	24759	MR0.68	10		
L 40- 42, 44,		320937					
L 56- 58		320937					
L 5, 10, 63,	CORE, TOROID, FERRITE, .047X.138X.118	321182	89536	321182	4		
L 64		321182					
L 11, 51	INDUCTOR, 270 UH, +/-5%, 8 MHZ, SHI DED	186270	72259	WEE270	2		
L 17	INDUCTOR, 390 UH, +/-5%, 6.9 MHZ, SHI DED	186288	72259	WEE390	1		
L 24	INDUCTOR, 4 TURN	755314	89536	755314	1		
L 43	INDUCTOR, 10 UH, +/-10%, 53 MHZ, SHI DED	249078	24759	MR10	1		
L 49	INDUCTOR, ADJ 33.0MH	774299	89536	774299	1		
L 50	INDUCTOR, ADJ 44.2MH	774307	89536	774307	1		
L 59	INDUCTOR, 125UH	738484	89536	738484	1		
L 62	INDUCTOR, 470 UH, +/-5%, 6.5 MHZ, SHI DED	147827	72259	WEE470	1		
L 66	INDUCTOR, 0.82UH, +/-10%, 200MHZ, SHI DED	320945	89536	320945	1		
L 67, 68	CORE, TOROID, FERRITE, .079X.185X.291	219535	25088	862110A5030X025C	2		
L 70	INDUCTOR, 0.044UH, +/-15%, 500MHZ, SHI DED	249110	72259	WEE0R044	1		
MF 1	FWR, SYNTHESIZER	774117	89536	774117	1		
MF 38	COMPONENT HOLDER	422865	98159	2829-75-2	1		
Q 1	* IC, VOLT REG, FIXED, 15 VOLTS, 0.1 AMPS	429910	07263	uA78L05AWC	1	1	
Q 2, 33, 37	* TRANSISTOR, SI, NPN, HI FREQ, SMALL SIGNAL	535013	04713	BF691	3	1	
Q 3	* TRANSISTOR, SI, NPN, HI FREQ, SMALL SIGNAL	723379	89536	723379	1	1	
Q 4, 5	* TRANSISTOR, SI, NPN, HI SPEED SWITCH	369629	07263	543576	2	1	
Q 10, 13, 14	* TRANSISTOR, SI, NPN, FEET, 10-72	477229	18324	SD213EE	3	1	
Q 11, 12	* TRANSISTOR, SI, NPN, FEET, 10-92	604678	17056	J2464	2	1	
Q 15, 21, 23,	* TRANSISTOR, SI, NPN, SMALL SIGNAL	218496	04713	2N3904	6	1	
Q 39- 41		218396					
Q 16, 17, 44	* TRANSISTOR, SI, NPN, SMALL SIGNAL	248351	04713	MF5918	3	2	
Q 18, 38	* TRANSISTOR, SI, NPN, SMALL SIGNAL	225599	07263	2N4250	2	1	
Q 20	* TRANSISTOR, SI, NPN, DARKINGTON	381798	04713	MF5A-13	1		
Q 22	* TRANSISTOR, SI, NPN, SMALL SIGNAL	195974	64713	2N3906	1	1	
Q 26, 27	* TRANSISTOR, SI, NPN, UHF/VHF USE	403634	12040	J310	2	1	
Q 28	* TRANSISTOR, SI, NPN, SMALL SIGNAL	418707	04713	MF56562	1	1	
Q 32, 35	* TRANSISTOR, SI, NPN, SMALL SIGNAL	483156	89536	483156	2	1	
Q 67	* TRANSISTOR, SI, NPN, DUAL, 10-71	453829	89536	453829	1	1	
R 1	RES, CC, 120, +/-10%, 0.5W	108696	01121	EB1211	1		
R 2, 159, 201,	RES, CF, 0.51, +/-5%, 0.25W	381954	80031	CR251-4-5P0R5E	4		
R 209		381954					
R 3, 25, 32	RES, CC, 51, +/-5%, 0.125W	266262	01121	BB5105	3		
R 4	RES, CF, 430, +/-5%, 0.25W	441568	80031	CR251-4-5P430E	1		
R 5	RES, CC, 24, +/-5%, 0.125W	681932	89536	681932	1		
R 6, 56, 58,	RES, CC, 100, +/-5%, 0.125W	714469	89536	714469	21		
R 66- 69, 124,		714469					
R 127, 133-139,		714469					
R 210, 212, 215,		714469					
R 216		714469					
R 7, 44, 94,	RES, CF, 1K, +/-5%, 0.25W	343426	80031	CR251-4-5P1K	8		
R 148, 152, 154,		343426					
R 169-170		343426					
R 8	RES, CF, 470, +/-5%, 0.25W	343434	80031	CR251-4-5P470L	1		
R 9, 39	RES, CF, 200, +/-5%, 0.25W	441451	80031	CR251-4-5P200E	2		
R 10	RES, CC, 33, +/-5%, 0.125W	720920	89536	720920	1		
R 11, 74, 100,	RES, CF, 1.5K, +/-5%, 0.25W	343418	80031	CR251-4-5P1K5	4		
R 153		343418					
R 12, 46, 165,	RES, CC, 510, +/-5%, 0.125W	715383	89536	715383	8		
R 167, 171, 172,		715383					
R 177, 211		715383					
R 13	RES, CC, 150, +/-5%, 0.5W	186056	89536	186056	1		
R 14, 15, 198	RES, CC, 30, +/-5%, 0.125W	512723	01121	BB3005	3		
R 21, 22	RES, CC, 15, +/-10%, 0.125W	261800	89536	261800	2		
R 23, 24, 40	RES, CF, 56, +/-5%, 0.25W	342618	80031	CR251-4-5P56E	3		
R 26, 31, 65,	RES, MF, 100, +/-1%, 0.125W, 100FFM	168195	91637	CMF551000F	4		
R 101		168195					
R 27	RES, MF, 36.5K, +/-1%, 0.125W, 100FFM	235309	91637	CMF553652F	1		
R 28	RES, MF, 21.5K, +/-1%, 0.125W, 100FFM	168278	89536	168278	1		
R 29	RES, MF, 22.6K, +/-1%, 0.125W, 100FFM	288431	91637	CMF552262F	1		
R 30	RES, MF, 57.6K, +/-1%, 0.125W, 100FFM	289116	91637	CMF555762F	1		
R 33, 161	RES, CF, 51, +/-5%, 0.25W	414540	80031	CR251-4-5P51E	2		
R 41	RES, CF, 270, +/-5%, 0.25W	348789	80031	CR251-4-5P270L	1		
R 42	RES, CF, 180, +/-5%, 0.25W	441436	80031	CR251-4-5P180E	1		
R 43	RES, CF, 91, +/-5%, 0.25W	441683	80031	CR251-4-5P91E	1		
R 55	RES, CF, 2.7K, +/-5%, 0.25W	386490	80031	CR251-4-5P2K7	1		
R 72, 202	RES, CF, 51K, +/-5%, 0.25W	376434	80031	CR251-4-5P51K	2		
R 73	RES, CF, 3.3K, +/-5%, 0.25W	348813	80031	CR251-4-5P3K3	1		
R 75	RES, MF, 1.91K, +/-1%, 0.125W, 100FFM	236877	89536	236877	1		
R 76, 85	RES, MF, 10K, +/-1%, 0.125W, 100FFM	168260	91637	CMF551002F	2		
R 77	RES, MF, 40K, +/-0.1%, 0.125W, 25FFM	321489	89536	321489	1		
R 78	RES, MF, 9K, +/-0.1%, 0.125W, 50FFM	236695	89536	236695	1		
R 79	RES, MF, 1K, +/-0.1%, 0.25W, 50FFM	225813	89536	225813	1		
R 80, 88	RES, MF, 4.99K, +/-1%, 0.125W, 100FFM	168252	91637	MF11-84991	2		
R 81, 92, 93,	RES, MF, 1K, +/-1%, 0.125W, 100FFM	168229	91637	CMF551001F	5		
R 182, 191		168229					
R 82	RES, VAR, CLKM, 5K, +/-10%, 0.5W	288282	75378	3601052A2	1		
R 83	RES, CF, 75K, +/-5%, 0.25W	394130	80031	CR251-4-5P75K	1		

LIST OF REPLACEABLE PARTS

TABLE 5-6. ALAY SYNTHESIZER PCA
(SEE FIGURE 5-6).

REFERENCE DESIGNATOR	DESCRIPTION	QUANTITY	FLUKE STOCK NO.	MFGS SPLY CODE	MANUFACTURERS PART NUMBER OR GENERIC TYPE	QTY	R S Q	N O T E
R 84	RES, MF, 3.01K, +1%, 0.125W, 100PFM	1	312645	91637	CMF553011F	1		
R 86	RES, CF, 200K, +5%, 0.25W	1	441485	80031	CR251-4-5F200K	1		
R 87	RES, VAR, CERAM, 2K, +10%, 0.5W	1	309666	89536	309666	1		
R 89	RES, MF, 6.49K, +1%, 0.125W, 100PFM	1	294900	91637	CMF556491F	1		
R 90	RES, VAR, CERAM, 1K, +10%, 0.5W	1	275750	11236	3601103A	1		
R 91	RES, MF, 12.4K, +1%, 0.125W, 100PFM	1	261644	91637	CMF551242F	1		
R 95	RES, CF, 1K, +5%, 0.25W	1	441691	80031	CR251-4-5F1K1	1		
R 96	RES, CF, 820, +5%, 0.25W	1	442327	80031	CR251-4-5F820E	1		
R 97	RES, CF, 6.8K, +5%, 0.25W	1	368761	80031	CR251-4-5F6.8K	1		
R 98, 121, 147	RES, CF, 100, +5%, 0.25W	4	348771	80031	CR251-4-5F100E	4		
R 149			348771					
R 99	RES, MF, 1.5K, +1%, 0.125W, 100PFM	1	313098	91637	CMF551501F	1		
R 102, 109	RES, CF, 10K, +5%, 0.25W	2	348839	80031	CR251-4-5F10K	2		
R 104	RES, VAR, CERAM, 10K, +10%, 0.5W	1	309674	75378	3601103A	1		
R 105	RES, CF, 18K, +5%, 0.25W	1	348862	80031	CR251-4-5F18K	1		
R 106	RES, CF, 2K, +5%, 0.25W	1	441469	80031	CR251-4-5F2K	1		
R 107	RES, MF, 2.55K, +1%, 0.125W, 100PFM	1	325498	91637	CMF552551F	1		
R 110, 112, 218	RES, CF, 36, +5%, 0.25W	3	442236	80031	CR251-4-5F36L	3		
R 116	RES, MF, 1.27K, +1%, 0.125W, 100PFM	1	267369	91637	CMF551271F	1		
R 117, 118	RES, CF, 220, +5%, 0.25W	2	342626	80031	CR251-4-5F220E	2		
R 119, 162	RES, CC, 10K, +5%, 0.125W	1	643940	01121	BB1035	1		
R 120, 163	RES, CF, 4.7K, +5%, 0.25W	2	348821	01121	CR4725	2		
R 122	RES, CF, 8.2K, +5%, 0.25W	1	441675	80031	CR251-4-5F8K2	1		
R 123	RES, CF, 33K, +5%, 0.25W	1	348888	80031	CR251-4-5F33K	1		
R 145	RES, CF, 1M, +5%, 0.25W	1	348987	80031	CR251-4-5F1M	1		
R 146, 150	RES, CF, 390, +5%, 0.25W	2	441543	80031	CR251-4-5F390E	2		
R 151	RES, CF, 2.2K, +5%, 0.25W	1	343400	80031	CR251-4-5F2K2	1		
R 160	RES, CF, 750, +5%, 0.25W	1	441659	80031	CR251-4-5F750E	1		
R 164	RES, CF, 300, +5%, 0.25W	1	441519	80031	CR251-4-5F300E	1		
R 178, 179	RES, CF, 5.6, +5%, 0.25W	2	441618	80031	CR251-4-5F5R6	2		
R 180, 192	RES, MF, 1.78, +1%, 0.125W, 100PFM	2	442996	89536	442996	2		
R 181, 193	RES, MF, 1.05K, +1%, 0.125W, 100PFM	2	295530	91637	CMF551051F	2		
R 183, 194	RES, MF, 3.24K, +1%, 0.125W, 100PFM	2	223578	91637	CMF553241F	2		
R 184, 195, 197	RES, CC, 180, +5%, 0.125W	4	512756	01121	BB1815	4		
R 200			512756					
R 185, 199	RES, MF, 249, +1%, 0.125W, 100PFM	2	148203	91637	CMF55249F	2		
R 186	RES, CC, 47, +5%, 0.125W	1	512061	01121	BB4705	1		
R 187, 189	RES, CC, 120, +5%, 0.125W	1	513978	01121	BB1215	1		
R 188, 196	RES, CC, 12, +5%, 0.125W	2	714451	89536	714451	2		
R 190	RES, CF, 5.1, +5%, 0.25W	1	441287	80031	CR251-4-5F5R1	1		
R 204	RES, MF, 2.49K, +1%, 0.125W, 100PFM	1	226209	91637	CMF552491F	1		
R 205	RES, MF, 2.37K, +1%, 0.125W, 100PFM	1	293720	91637	CMF552371F	1		
R 206, 220	RES, VAR, CERAM, 200, +10%, 0.5W	2	275743	89536	275743	2		
R 213, 214	RES, CC, 200, +5%, 0.125W	2	713917	89536	713917	2		
R 217	RES, CF, 1.8K, +5%, 0.25W	1	441444	80031	CR251-4-5F1.8K	1		
R 219	RES, CC, 510, +5%, 0.5W	1	108951	01121	RC0206F511JS	1		
R 221	RES, MF, 2.61K, +1%, 0.125W, 100PFM	1	289983	91637	CMF552611F	1		
TP 1, 3, 14	TEST POINT	12	267500	00779	87022-1	12		
TP 17, 35, 55			267500					
TP 2, 7, 11	TEST POINT	35	512889	02660	62395	35		
TP 12, 14, 16			512889					
TP 22, 25, 27			512889					
TP 31, 34, 36			512889					
TP 46, 48, 54			512889					
TP 56			512889					
U 1	* IC, ECL, 1.5 GHZ DIVIDE BY 2	1	707943	89536	707943	1		
U 6	* 3DB COUPLER	1	704965	89536	704965	1		
U 7, 8	* MIXER, DOUBLE BALANCED, 1-500 MHZ	2	733105	89536	733105	2		
U 9	* IC, HPLR, MONOLITHIC VHF-UHF AMPLIFIER	1	723387	89536	723387	1		
U 10	* IC, OP AMP, QUAD, JFET INPUT, 10-5 CASE	1	483438	89536	483438	1		
U 14, 15	* IC, TTL, 100MHZ DIV BY 2, DIV BY 5 CNTR	2	473835	01295	SN74LS196N	2		
U 16, 58	* IC, LSTTL, DUAL, DIV BY 2, DIV BY 5 CNTR	2	483594	01295	SN74LS390N	2		
U 17	* IC, STTL, 360 CELL GATE ARRAY	1	723718	89536	723718	1		
U 18	* IC, ECL, DUAL D M/S F/F, W/SET&RESET	1	454959	04713	MC10131P	1		
U 19	* IC, ECL, QUAD 2 INPUT NOR GATE	1	380881	04713	MC10102P	1		
U 20	* IC, ECL, DIV BY 10, DIV BY 11 COUNTER	1	454900	89536	454900	1		
U 26, 30, 32	* IC, LSTTL, OCTAL D F/F, +EDG TRG, W/CLEAR	4	454892	01295	SN74LS273N	4		
U 27, 29	* IC, CMOS, 10BIT DAC, 10BIT ACCUR, CUR OUT	2	507566	24355	AD7533LN	2		
U 28	* IC, OP AMP, DUAL, JFET INPUT, 8 PIN DIP	1	495192	12040	LF353BN	1		
U 33	* IC, STTL, 360 CELL GATE ARRAY	1	723700	89536	723700	1		
U 34	* IC, TTL, QUAD 2 INPUT NAND GATE	1	654640	07263	74F00PC	1		
U 35, 66	* IC, TTL, DUAL D F/F, +EDG TRG, W/CLEAR&SET	2	659508	07263	74F74PC	2		
U 37	* IC, LSTTL, 3-B LINE DCMR W/ENABLE	1	407585	01295	SN74LS138N	1		
U 38	* IC, OP AMP, QUAD, JFET INPUT, 14 PIN DIP	1	429035	01295	SN74LS244N	1		
U 41	* IC, OP AMP, QUAD, JFET INPUT, 14 PIN DIP	1	659748	89536	659748	1		
U 42	* IC, COMPARATOR, QUAD, 14 PIN DIP	1	387233	12040	LM339N	1		
U 43, 44, 59	* IC, STTL, DUAL D F/F, +EDG TRG, W/SET&CLR	3	418269	01295	SN74S74N	3		
U 45	* IC, STTL, DUAL 2 WIDE 2 IN AND-OR-INVRT	1	495473	01295	SN74S51N	1		
U 46	* IC, ARRAY, 5 TRANS, 5 I/O, 2-PNP, 3-NPN	1	418954	02735	CA3096F	1		
U 47	* IC, LSTTL, REIKG MONOSTAB MULTIVIB W/CLR	1	404186	01295	SN74LS123N	1		
U 48, 60	* IC, OP AMP, JFET INPUT, 8 PIN DIP	2	472779	12040	LF386N	2		
U 49	* IC, OP AMP, SELECTED GHW 600KHZ	1	418566	12040	LM358N	1		
U 50	* ISOLATOR, OPTO, LED TO TRANSISTOR, DUAL	1	454330	07263	MCT-6	1		
U 54	* IC, TTL, HEX INVERTER	1	634444	07235	74F04PC	1		
U 55	* IC, TTL, 4-INPUT MULTIFLEXER	1	707935	89536	707935	1		
U 61	* IC, ECL, DIVIDE BY 4 PRESCALER	1	722157	89536	722157	1		
U 62, 63	* IC, ECL, DUAL D M/S F/F, +EDG TRG	2	525345	04713	MC102311	2		
U 64	* IC, ECL, TRIPLE 2/3 INPUT OR-NOR GATE	1	723437	89536	723437	1		
U 65	* IC, STTL, QUAD 2 INPUT NAND GATE	1	363580	01295	SN7400SN	1		
W 1, 2	CABLE ASSY, RF JUMPER	2	716985	89536	716985	2		
W 3	WIRE, PVC, UL1061, 26AWG, VIO BLK, 10 PR	1	597849	89536	597849	1		
XI 101	SOCKET, 1 ROW, FWH, 0.100CTR, 9 POS	1	436774	30035	33-109 1-09	1		
XJ 104, 107, 108	SOLDER, SINGLE LEAD, FOR 0.034 0.037 PIN	3	732826	89536	732826	3		

LIST OF REPLACEABLE PARTS

TABLE 5-6. A201 SYNTHESIZER PCA
(SEE FIGURE 5-6).

REFERENCE DESIGNATOR	DESCRIPTION	FLUKE STOCK NO.	MFRS SPLY CODE	MANUFACTURERS PART NUMBER OR GENERIC TYPE	QTY	Q	N O T E
XP 101, 102, 111	SOCKET, SINGLE, FWD, FOR .042-.049 PIN	544056	89536	544056	3		
XU 10, 15, 34,	SOCKET, IC, 14 PIN	276527	09922	D1LB8P-108	13		
XU 35, 41, 42,		276527					
XU 43, 44, 45,		276527					
XU 47, 50, 59,		276527					
XU 65, 66		276527					
XU 16, 18, 19,	SOCKET, IC, 16 PIN	276535	91506	316-AG39D	11		1
XU 27, 29, 37,		276535					1
XU 46, 62, 63,		276535					1
XU 64		276535					1
XU 17	SOCKET, IC, 28 PIN	448217	91506	328-AG39D	1		
XU 26, 30, 32,	SOCKET, IC, 20 PIN	454421	09922	D1LB20P-108	5		
XU 38		454421					
XU 28, 48, 49,	SOCKET, IC, 8 PIN	478016	91506	308-AG39D	5		
XU 50, 60		478016					
XU 33	SOCKET, IC, 24 PIN	376236	91506	324-AG39D	1		
Y 1	CRYSTAL, 10MHZ, +/-0.001%, HC-35/U	536565	33096	FB1360	1	1	
Z 1	RES, NET, CERM, CUSTOM	501841	89536	501841	1		
Z 5	RES, NET, SIP, 10 PIN, 9 RES, 510, +/-2%	478800	89536	478800	1		
Z 6	RES, NET, SIP, 6 PIN, 5 RES, 100K, +/-2%	412726	89536	412726	1		
Z 9	RES, NET, DIP, 16 PIN, 8 RES, 1K, +/-5%	358119	01121	314	1	1	
Z 10	RES, NET, SIP, 6 PIN, 5 RES, 510, +/-2%	459974	89536	459974	1		
Z 11	RES, NET, SIP, 6PIN, 5RES, 2.7K	772947	89536	772947	1		

NOTE 1= ALSO INCLUDES XZ1 AND XZ29

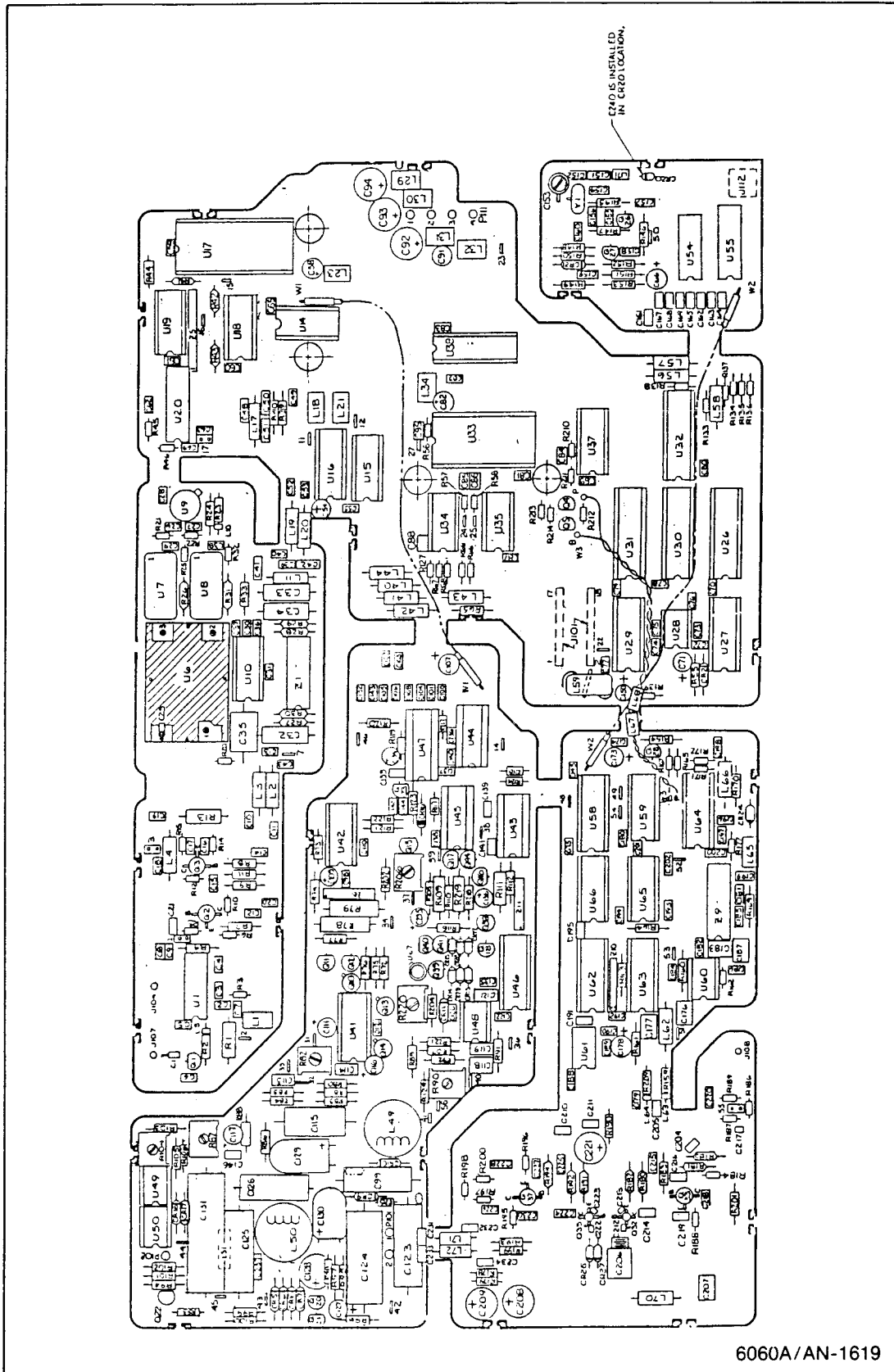

6060A/AN-1619

Figure 5-6. A2A1 Synthesizer PCA

LIST OF REPLACEABLE PARTS

TABLE 5-7. A2A2 VCO PLA
(SEE FIGURE 5-7.)

REFERENCE DESIGNATOR	DESCRIPTION	FLUKE STOCK NUMBER	MILS SPLY CODE	MANUFACTURERS PART NUMBER	QTY	UNIT	QTY	UNIT
A NUMERICS	S DESCRIPTION	NO	CODE	GENERIC TYPE				
C 1, 4, 6, 10, 13, 14, 20, 28, 32, 33, 38	CAP, CER, 1000PF, +-10%, 50V, X7R	484378	89536	484378	11			
C 2	CAP, CER, 1800PF, +-5%, 50V, COG	528547	89536	528547	1			
C 3, 30	CAP, CER, 1.5FF, +-0.5FF, 50V, COG	514166	89536	514166	2			
C 5, 15	CAP, CER, 4.3FF, +-0.5FF, 50V, COG	514216	89536	514216	2			
C 7, 9, 12, 16, 19, 22, 23, 26, 27	CAP, CER, 160PF, +-5%, 100V, COG	603506	56289	C023B501E181M	11			
C 8	CAP, CER, 10PF, +-2%, 100V, COG	512343	89536	512343	1			
C 11, 21	CAP, CER, 10PF, +-5%, 50V, COG	494781	89536	494781	2			
C 24, 25	CAP, AL, 220UF, +-50-20%, 16V	435990	57640	SM/VH	2			
C 29, 31	CAP, CER, 3.3FF, +-0.5FF, 50V, COG	514208	89536	514208	2			
C 34	CAP, CER, 100PF, +-5%, 50V, COG	514133	89536	514133	1			
C 35	CAP, CER, 2.7FF, +-0.5FF, 50V, COG	519793	89536	519793	1			
C 36	CAP, CER, 22FF, +-2%, 100V, COG	512871	89536	512871	1			
C 39, 40	CAP, 47 UF	746990	89536	746990	2			
C 41	CAP, CER, 1.8FF, +-0.25FF, 100V, COG	512897	89536	512897	1			
CR 1, 2	DIODE, SI, VARACTOR, PIV= 28V	741504	89536	741504	2	1		
CR 3, 4	* DIODE, SI, VARACTOR, PIV= 30V, HYPER ABRU	722140	89536	722140	2	1		
L 1	CHOKER, 6TURN	320911	89536	320911	1			
MF 2	SPACER, RND, SOLUBLE	334797	32559	10-35-15-E	4			
P 201, 202	SOCKET, SINGLE, PWB, FOR .042-.049 PIN	544056	89536	544056	3			
P 203	SOCKET, SINGLE, PWB, FOR 0.012-0.022 PIN	376418	22526	75060-005	1			
P 204	PIN TEST BASE	698472	89536	698472	1			
Q 1, 3	* TRANSISTOR, SI, NPN, SMALL SIG, MICROWAVE	483164	89536	483164	2			
Q 2, 4, 5	* TRANSISTOR, SI, NPN, HI-FREQ, SMALL SIGNAL	535013	04713	BFR91	3	1		
R 1, 9, 23	RES, CHIP, CERMET 180 +-5% 0.125W	720649	89536	720649	3			
R 2, 16	RES, CF, 360, +-5%, 0.125W	772277	89536	772277	2			
R 3, 17	RES, CC, 680, +-5%, 0.125W	512798	01121	BB6815	2			
R 4, 19	RES, CC, 1.6M, +-5%, 0.125W	740316	89536	740316	2			
R 5, 11	RES, CF, 5.6, +-5%, 0.25W	441618	80031	CR251-4-5F5R6	2			
R 6, 18	RES, CF, 1.5M, +-5%, 0.25W	349001	80031	CR251-4-5F1M5	2			
R 7, 21	RES, MF, 3.24K, +-1%, 0.125W, 100PFM	223578	91637	CMF553241F	2			
R 8, 22	RES, MF, 1.05K, +-1%, 0.125W, 100PFM	293530	91637	CMF551051F	2			
R 10, 24	RES, MF, 249, +-1%, 0.125W, 100PFM	168403	91637	CMF55249F	2			
R 12, 26	RES, CHIP, CERMET 12 +-5% 0.125W	715102	89536	715102	2			
R 13	RES, CHIP, CERMET 68, +-5%, 0.125W	747675	89536	747675	1			
R 14	RES, CHIP, CERMET 120, +-5%, 0.125W	747683	89536	747683	1			
R 15	RES, CHIP, CERMET, 100, +-5%, 0.125W	746297	89536	746297	1			
R 20	RES, CF, 10K, +-5%, 0.25W	348839	80031	LR251-4-5F10K	1			
R 25, 30	RES, MF, 649, +-1%, 0.125W, 100PFM	309955	91637	CMF556490F	2			
R 27, 29	RES, CHIP, CERMET 130 +-5% 0.125W	720623	89536	720623	2			
R 28	RES, CHIP, CERMET 47 +-5% 0.125W	720631	89536	720631	1			
R 31	RES, CHIP, CERMET, 15, +-5%, 0.125W	756940	89536	756940	1			
R 32	RES, CC, 200, +-5%, 0.125W	713917	89536	713917	1			
W 2	VCO CABLE, SEMI RIGID	762153	89536	762153	1			

THE FOLLOWING COMPONENTS ARE NON-FIELD REPLACEABLE:

- C1, 3, 4, 5, 6, 8, 10, 11, 14, 15, 18, 19, 21, 26, 27, 29, 31, 32, 36, 37
- CR1, 2, 3, 4
- Q1, 2, 3, 4
- R1, 2, 3, 4, 16, 17, 18, 19, 25, 30

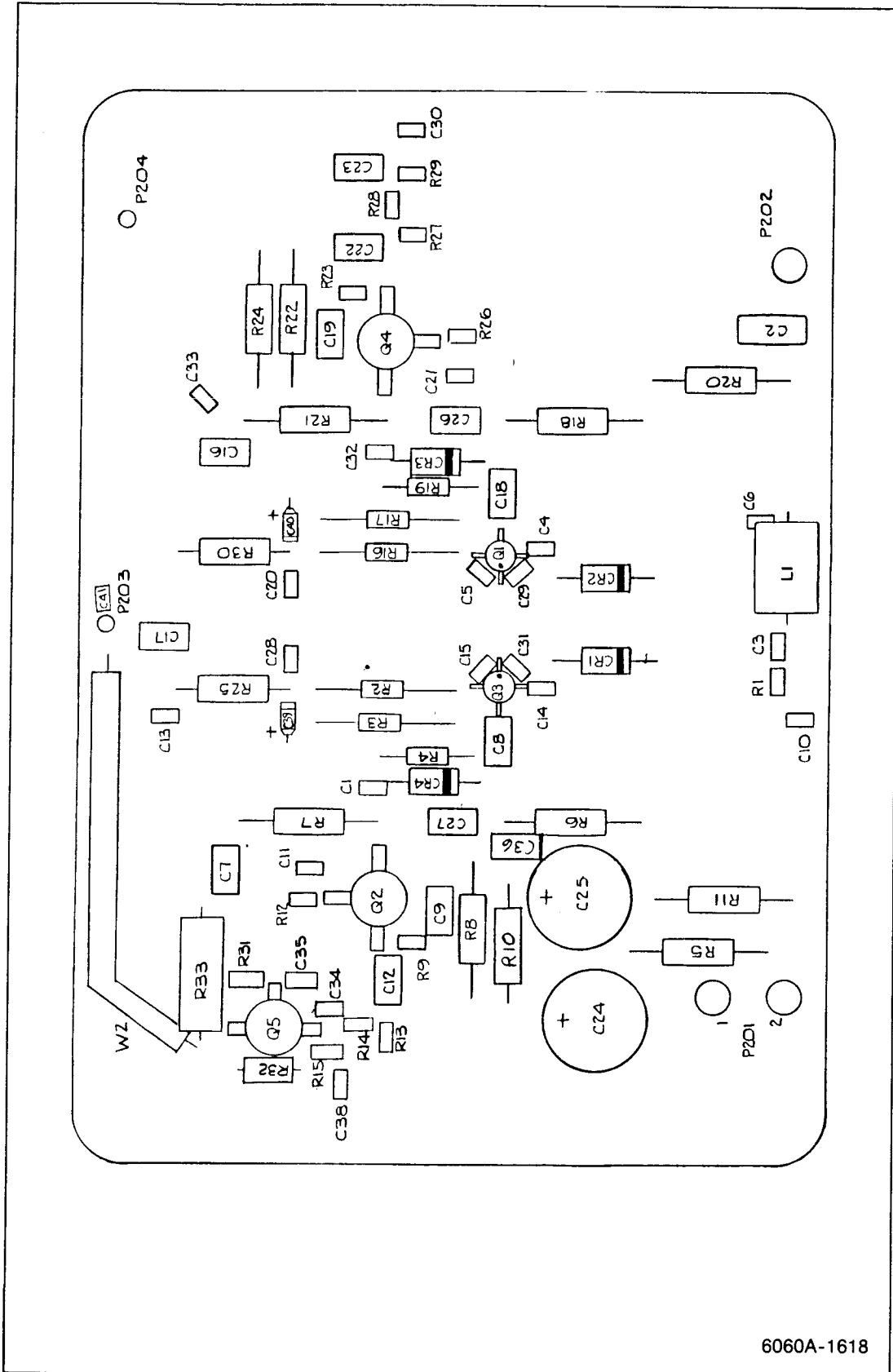

6060A-1618

Figure 5-7. A2A2 VCO PCA

LIST OF REPLACEABLE PARTS

TABLE 5-8. AL244 OUTPUT PCA
(SEE FIGURE 5-8.)

REFERENCE DESIGNATOR	FLUKE STOCK NO.	PKGS SUPPLY CODE	MANUFACTURERS PART NUMBER OK GENERIC TYPE	QTY	N O I E			
A-NUMERICS	S	DESCRIPTION						
C 101, 104, 106, C 115, 117, 137, C 138, 144, 151, C 152, 154, 156, C 231, 238, 240, C 243, 246, 247, C 250, 253, 301, C 303, 305, 307, C 314, 317-321, C 416		CAP, CER, 100PF, +-2%, 100V, COG	512848 512848 512848 512848 512848 512848 512848 512848 512848 512848	51406	RFE121	40		
C 103, 145, 148, C 201, 207, 210, C 213, 214, 235, C 245, 249, 260, C 265, 266, 272, C 274, 302, 304, C 306, 403, 404, C 406, 412		CAP, FOLYEST, 0.1UF, +-20%, 50V	732883 732883 732883 732883 732883 732883 732883	89536	732883	24		
C 107, 124, 147, C 157, 242, 254, C 256, 259, 269, C 270		CAP, CER, 0.001UF, +-20%, 100V, X7K	402966 402966 402966	72982	8121 A100-W5K-102M	11		
C 108, 119, 121, C 125		CAP, CER, 5.6PF, +-0.25PF, 100V, COH	512954 512954	89536	512954	5		
C 109, 110, 118 C 111, 236, 237 C 112, 113 C 114, 244, 248, C 263		CAP, CER, 3.9PF, +-0.25PF, 100V, COJ CAP, CER, 3.3PF, +-0.25PF, 100V, COJ CAP, CER, 2.2PF, +-0.25PF, 100V, COG CAP, CER, 1.8PF, +-0.25PF, 100V, COK	512947 519330 362731 512897	89536 89536 89536 89536	512947 519330 362731 512897	3 3 2 4		
C 120, 224, 275 C 125, 127, 129, C 131, 133, 135, C 149		CAP, CER, 2.7PF, +-0.25PF, 100V, COJ CAP, CER, 0.01UF, +-20%, 50V, Z5U	363705 614214 614214	89536 72982	363705 8121-050-651-10NF M	3 7		
C 126 C 130, 134 C 139 C 140 C 142 C 146 C 202, 204, 206, C 208, 211, 261 C 264, 271, C 276		CAP, AL, 22UF, +-20%, 16V CAP, AL, 15UF, +-20%, 35V CAP, CER, 1200PF, +-20%, 100V, X7K CAP, CER, 1800PF, +-5%, 50V, COG CAP, CER, 4700PF, +-20%, 100V, X7K CAP, CER, 220PF, +-2%, 100V, COG CAP, AL, 2.2UF, +-20%, 50V	614750 614024 358283 528547 362871 512111 614875 614875 614875 614875	89536 89536 72982 89536 72982 51406 89536	614750 614024 8121-A100-W5K-122M 528547 8121-A100-W5K-472M RFE121 614875	1 2 1 1 1 1 10		
C 205 C 209, 212, 230 C 216, 218, 220, C 223 C 217 C 219, 226, 229, C 277		CAP, CER, 39PF, +-2%, 100V, COG CAP, CER, 27PF, +-2%, 100V, COG CAP, CER, 8.2PF, +-0.25PF, 100V, COH	512942 362749 715359 715359	89536 51406 89536	512942 RFE121 715359	1 3 4		
C 221 C 222 C 225, 252 C 251, 405 C 262 C 267, 411 C 280 C 322, 409 C 401, 402 C 407, 408 C 410 C 420		CAP, CER, 18PF, +-2%, 100V, COG CAP, CER, 4.7PF, +-0.25PF, 100V, COH CAP, CER, 10PF, +-2%, 100V, COG CAP, CER, 12PF, +-2%, 100V, COG CAP, CER, 6.8PF, +-0.25PF, 100V, COH CAP, CER, 47PF, +-2%, 100V, COG CAP 3.3 CAP, TA, 2.2UF, +-20%, 35V CAP, CER, 1.5PF, +-0.25PF, 100V, COK CAP, TA, 0.47UF, +-20%, 35V CAP, AL, 47UF, +-50%, 20%, 16V CAP, FOLYEST, 0.0786UF, +-1%, 50V CAP, TA, 4.7UF, +-20%, 25V CAP 1.0PF	512335 362772 362772 512343 376871 512327 512368 772848 485185 529909 161349 436006 422998 161943 512145	51406 89536 89536 89536 89536 89536 56289 89536 56349 89536 89536 56289 89536	8D870-100V 362772 512343 376871 512327 512368 772848 196205X0035KA1 529909 196D474X0035HA1 SM/VB 196D475X0025KA1 512145	1 6 1 1 2 2 2 2 1 1 1 1		
CR 101, 105, 111- CR 116, 118, 120 CR 203, 210 CR 102, 104, 106- CR 110, 129, 204- CR 209	*	DIODE, SI, PIN, 10-FREQ, BV=100.0V DIODE, SI, PIN, RF ATTENUATING	402776 402776 402776	28480	HF3379	12	1	
CR 117, 119 CR 121, 301 CR 125 CR 126 CR 123, 124 CR 127, 128 CR 130, 201 CR 302 CR 401, 402 CR 403	*	DIODE, SI, PIN, RF CUR CONT RESIST DIODE ZENER, UNCOMP, 5.1V, 5%, 20.0MA, 0.4W ZENER, UNCOMP, 4.3V, 5%, 20.0MA, 0.4W DIODE, SI, SCHOTTKY, MATCHED SET OF 2 DIODE, SI, BV= 50.0V, IO=150MA, SILECIV DIODE, SI, SCHOTTKY BARRIER, SMALL SIGNAL DIODE, SI, BV= 75.0V, IO=150MA, 500 HW ZENER, UNCOMP, 15.0V, 5%, 8.5MA, 0.4W DIODE, SI, SCHOTTKY BARRIER, SMALL SIGNAL ZENER, COMP, 6.3V, 2%, 50 PFM TC, 7.5MA CONNECTOR, 4 PIN CHOKE, 6TURN	742296 159798 180455 722470 234448 535195 203323 266601 313247 172148 417329 320911 320911 320911	89536 89536 89536 89536 07910 28480 07910 89536 89536 89536 89536	742296 1N751A 1N749A 722470 TD9039 5082-2800 1N444B 1N965B HF5082-6264 172148 417329 320911	2 2 1 1 2 2 2 1 1 2 1 6	2 1 3 1 1 1 1 1 1 1	
L 102, 106, 108, L 110, 115, 230 L 103-105, 225 L 113, 116, 209 L 210, 214-218 L 220, 224, 227 L 201-203, 228 L 221		INDUCTOR, 0.68 UH, +/-10%, 221MHZ, SHIELDED INDUCTOR, 10 TURNS	320937 463448 463448 463448	24759 89536	MR0.68 463448	4 12		
L 201-203, 228 L 221		INDUCTOR, 6800 UH, +/-10%, 1.5MHZ, SHIELDED INDUCTOR, 1500 UH, +/-10%, 2.5MHZ, SHIELDED	363184 343863	24759	MR-6800 MR-1500	4 1		
MF 1 MF 40 P 101, 113 P 102, 107, 108 P 104 P 106		HET SHIELD COMPONENT HOLDER SOCKET, SINGLE, FMB, FOR .042-.049 PIN PIN TEST BASE HEADER, 1 ROW, 0.100CTR, 10 PIN SOCKET, SINGLE, FMB, FOR 0.012-0.022 PIN	774190 422857 544056 698472 478693 376418	89536 98159 89536 89536 89536 22526	774190 2829-75 1 544056 698472 478693 75060-005	1 1 19 3 1 1		

LIST OF REPLACEABLE PARTS

TABLE 5-B. A2A4 OUTPUT PLAs
(SEE FIGURE 5-8.)

REFERENCE DESIGNATOR (ALPHANUMERIC)	QTY	DESCRIPTION	FLUKE STOCK NO.	MFRS SPLY CODE	MANUFACTURERS PART NUMBER OR GENERIC TYPE	TOT QTY	R	N
							S	T
Q 101, 102, 202	*	TRANSISTOR, SI, NPN, HI-FREQ, SMALL SIGNAL	535013	04713	2N3904	3		
Q 103, 302, 304, 306	*	TRANSISTOR, SI, NPN, SMALL SIGNAL	330803	07263	MPS6560	4	1	
Q 104, 201, 203, 205, 208, 210, 212, 214	*	TRANSISTOR, SI, PNP, SMALL SIGNAL	195974	64713	2N3906	8		
Q 105, 106	*	TRANSISTOR, SI, NPN, SMALL SIGNAL	218396	04713	2N3904	2	2	
Q 204, 206, 209, 211	*	TRANSISTOR, SI, NPN, HI-FREQ, SMALL SIGNAL	723379	89536	723379	4	1	
Q 207	*	TRANSISTOR, SI, NPN, SMALL SIG, MICROWAVE	483172	89536	483172	1	1	
Q 213, 215	*	TRANSISTOR, SI, NPN, HI-FREQ, SMALL SIGNAL	722256	89536	722256	2	1	
Q 301, 303, 305, 307	*	TRANSISTOR, SI, PNP, SMALL SIGNAL	418707	04713	MPS6562	4	1	
Q 401, 403	*	TRANSISTOR, SI, NPN, HI-FREQ, SWITCH	261578	15818	UC366J	2	1	
Q 402	*	TRANSISTOR, SI, NPN, HI-FREQ, SWITCH	376475	15818	UC2810J	1	1	
R 101, 102, 104, 114, 120, 151, 156, 269, 271, 316, 318, 320		RES, CF, 1K, +-5%, 0.25W	343426	80031	CR251-4-5F1K	19		
R 103, 121, 122		RES, CC, 39, +-5%, 0.125W	713909	89536	713909	3		
R 106		RES, CF, 470, +-5%, 0.25W	343434	80031	CR251-4-5F470E	1		
R 107		RES, CF, 200, +-5%, 0.25W	441451	80031	CR251-4-5F200E	1		
R 108, 124, 125		RES, MF, 2.15K, +-1%, 0.125W, 100PFM	293712	91637	CMF552151F	3		
R 109		RES, CC, 510, +-5%, 0.125W	715383	89536	715383	1		
R 110		RES, CC, 270, +-5%, 0.5W	159616	01121	BB2715	1		
R 111, 112, 159, 243, 245		RES, CC, 51, +-5%, 0.125W	266262	01121	BB5105	6		
R 113		RES, CC, 18, +-5%, 0.125W	500397	01121	BB1805	1		
R 123, 238		RES, MF, 2.67K, +-1%, 0.125W, 100PFM	289587	91637	CMF552671F	2		
R 126		RES, MF, 1.65K, +-1%, 0.125W, 100PFM	293662	91637	CMF551631	1		
R 127		RES, MF, 665, +-1%, 0.125W, 100PFM	320028	91637	CMF556650F	1		
R 128, 129		RES, MF, 124K, +-1%, 0.125W, 100PFM	288407	91637	CMF551243F	2		
R 130		RES, MF, 1.54K, +-1%, 0.125W, 100PFM	289066	91637	CMF551541F	1		
R 131		RES, MF, 3.48K, +-1%, 0.125W, 100PFM	260687	91637	CMF553481F	1		
R 132		RES, MF, 24.3K, +-1%, 0.125W, 100PFM	236745	91637	CMF55	1		
R 133		RES, MF, 6.04K, +-1%, 0.125W, 100PFM	285109	91637	CMF556041F	1		
R 134		RES, MF, 21.5K, +-1%, 0.125W, 100PFM	168278	89536	168278	1		
R 135, 304, 413, 414		RES, MF, 10K, +-1%, 0.125W, 100PFM	168260	91637	CMF551002F	4		
R 136, 266		RES, MF, 2.55K, +-1%, 0.125W, 100PFM	325498	91637	CMF552551F	2		
R 137		RES, MF, 499, +-1%, 0.125W, 100PFM	168211	91637	CMF554990F	1		
R 138		RES, MF, 16.9K, +-1%, 0.125W, 100PFM	267146	91637	CMF551692F	1		
R 139		RES, MF, 34.8K, +-1%, 0.125W, 100PFM	261487	89536	261487	1		
R 140, 148, 149		RES, MF, 1K, +-1%, 0.125W, 100PFM	168229	91637	CMF551001F	3		
R 141		RES, MF, 37.4K, +-1%, 0.125W, 100PFM	276241	91637	CMF553743F	1		
R 142		RES, MF, 100K, +-1%, 0.125W, 100PFM	248807	91637	CMF551003F	1		
R 143, 147		RES, MF, 20K, +-1%, 0.125W, 100PFM	291872	91637	CMF552002F	2		
R 144		RES, VAR, CERM, 2K, +-10%, 0.5W	309666	89536	309666	1	1	
R 145		RES, MF, 66.5K, +-1%, 0.125W, 100PFM	289082	91637	CMF556652F	1		
R 146, 422		RES, MF, 49.9K, +-1%, 0.125W, 100PFM	268821	91637	CMF554992F	2		
R 150, 233, 242		RES, CC, 180, +-5%, 0.125W	512756	01121	BB1815	3		
R 152		RES, CF, 270, +-5%, 0.25W	348789	80031	CR251-4-5F270E	1		
R 153, 158, 314, 319		RES, CF, 4.7K, +-5%, 0.25W	348821	01121	CB4725	4		
R 154		RES, CC, 72, +-5%, 0.125W	474767	01121	BB182205	1		
R 155		RES, CF, 1, +-5%, 0.25W	357665	80031	CR251-4-5F1E	1		
R 157, 272		RES, CC, 1K, +-5%, 0.125W	643932	01121	BB1025	2		
R 201, 207, 213, 232, 240, 248, 265		RES, CF, 2K, +-5%, 0.25W	441469	80031	CR251-4-5F2K	7		
R 202		RES, CF, 360, +-5%, 0.25W	441469					
R 203, 209, 214		RES, MF, 287, +-1%, 0.125W, 100PFM	352286	80031	CR251-4-5F360E	1		
R 204, 205		RES, MF, 15, +-5%, 0.125W	443002	89536	443002	3		
R 206, 212, 217		RES, CF, 11, +-5%, 0.125W	740027	89536	740027	2		
R 208, 220, 234, 241		RES, CC, 150, +-5%, 0.5W	740019	89536	740019	3		
R 210, 211, 215, 216		RES, CF, 18, +-5%, 0.125W	186056	89536	186056	4		
R 218, 239		RES, MF, 6.65K, +-1%, 0.125W, 100PFM	740035	89536	740035	4		
R 219		RES, MF, 8.45K, +-1%, 0.125W, 100PFM	294918	91637	CMF551272F	2		
R 221		RES, MF, 1.21K, +-1%, 0.125W, 100PFM	221671	89536	221671	1		
R 222		RES, MF, 5.36K, +-1%, 0.125W, 100PFM	229146	91637	CMF551211F	1		
R 223		RES, CC, 300, +-5%, 0.5W	370981	89536	370981	1		
R 224, 262		RES, CF, 160, +-5%, 0.125W	108829	01121	EB3015	1		
R 225, 229		RES, CF, 75, +-5%, 0.125W	740092	89536	740092	2		
R 226		RES, CF, 51, +-5%, 0.125W	740068	89536	740068	2		
R 227		RES, VAR, CERM, 160, +-10%, 0.5W	740050	89536	740050	1		
R 228		RES, CF, 110, +-5%, 0.125W	275735	11236	360T-101A	1		
R 230, 231		RES, CC, 100, +-5%, 0.125W	740076	89536	740076	1		
R 235		RES, CC, 47, +-5%, 0.125W	714469	89536	714469	2		
R 236, 237		RES, CC, 47, +-5%, 0.125W	512061	01121	BB4705	1		
R 246		RES, MF, 5.76K, +-1%, 0.125W, 100PFM	512723	01121	BB3005	2		
R 249		RES, MF, 63.4, +-1%, 0.5W, 100PFM	260349	91637	CMF555761F	1		
R 250		RES, CC, 160, +-5%, 0.125W	155101	89536	155101	1		
R 251, 252		RES, CC, 24, +-5%, 0.125W	721027	89536	721027	1		
R 253		RES, CC, 110, +-5%, 0.125W	681932	89536	681932	2		
R 254		RES, CC, 720, +-5%, 0.125W	500983	01121	BB1115	1		
R 255		RES, CC, 300, +-5%, 0.125W	721159	89536	721159	1		
R 256		RES, CF, 120, +-5%, 0.125W	512772	01121	BB3015	1		
R 257		RES, CC, 15, +-10%, 0.125W	740084	89536	740084	1		
R 258		RES, CF, 1.2K, +-5%, 0.25W	261800	89536	261800	1		
R 259		RES, CC, 390, +-5%, 0.5W	441378	80031	CR251-4-5F1K2	1		
R 261		RESISTOR, CC, 330, +-5%, 0.5W	109082	89536	109082	1		
R 263, 264		RES, CF, 24, +-5%, 0.125W	108936	89536	108936	1		
R 267		RES, MF, 475, +-1%, 0.125W, 100PFM	740043	89536	740043	2		
			320010	91637	CMF554750F	1		

LIST OF REPLACEABLE PARTS

TABLE 5 B. A244 OUTPUT PCA
(SEE FIGURE 5 B.)

REFERENCE DESIGNATOR	DESCRIPTION	FLUKE STOCK NUMBER	MFRS SPLY CODE	MANUFACTURERS PART NUMBER	TOT QTY	R S T	N O
A (NUMERIC)	DESCRIPTION	NO.	CODE	GENERIC TYPE	QTY	Q	E
R 268	RES, MF, 22.1K, +-1%, 0.5W, 100PFM	151472	89536	151472	1		
R 302	RES, MF, 3.4K, +-1%, 0.125W, 100PFM	260323	91637	CMF 553401F	1		
R 303	RES, MF, 715, +-1%, 0.125W, 100PFM	313080	91637	CMF 557150F	1		
R 305	RES, MF, 392, +-1%, 0.125W, 100PFM	240299	91637	CMF 553920F	1		
R 306	RES, MF, 39.2K, +-1%, 0.125W, 100PFM	236414	91637	CMF 553922F	1		
R 307	RES, CF, 47, +-5%, 0.25W	441592	80031	CR251-4-5F47E	1		
R 308	RES, CF, 56K, +-5%, 0.25W	441626	80031	CR251-4-5F56K	1		
R 309	RES, VAR, CERM, 10K, +-10%, 0.5W	309674	75378	360T103A	1		
R 310	RES, MF, 523, +-1%, 0.125W, 100PFM	294835	91637	CMF 555230D	1		
R 311	RES, VAR, CERM, 200, +-10%, 0.5W	275743	89536	275743	1		
R 312	RES, MF, 294, +-1%, 0.125W, 100PFM	288472	91637	CMF 55294F	1		
R 313	RES, CF, 33K, +-5%, 0.25W	348888	80031	CR251-4-5F33K	1		
R 315	RES, CF, 620, +-5%, 0.25W	442319	80031	CR251-4-5F620E	1		
R 324	RES, CF, 62K, +-5%, 0.25W	348904	80031	CR251-4-5F62K	1		
R 401	RES, MF, 681, +-1%, 0.125W, 100PFM	543785	91637	CMF 556810F	1		
R 402	RES, CF, 1M, +-5%, 0.25W	348987	80031	CR251-4-5F1M	1		
R 403, 408	RES, MF, 3.32K, +-1%, 0.125W, 100PFM	312652	91637	CMF 553321F	2		
R 404, 407	RES, MF, 34.8, +-1%, 0.125W, 100PFM	343897	89536	343897	2		
R 405, 409	RES, MF, 4.99K, +-1%, 0.125W, 100PFM	168252	91637	MF1-84991	2		
R 406, 410	RES, MF, 71.5, +-1%, 0.125W, 100PFM	393603	91637	CMF 557155F	2		
R 411	RES, MF, 4.02K, +-1%, 0.125W, 100PFM	245325	91637	CMF 554021F	1		
R 412	RES, MF, 1.69K, +-1%, 0.125W, 100PFM	321414	91637	CMF 551691F	1		
R 415	RES, MF, 6.34K, +-1%, 0.125W, 100PFM	267344	91637	CMF 556341F	1		
R 416	RES, MF, 147K, +-1%, 0.125W, 100PFM	291344	91637	CMF 551473F	1		
R 417	RES, MF, 23.2K, +-1%, 0.125W, 100PFM	291351	91637	CMF 552322F	1		
R 418	RES, VAR, CERM, 100K, +-10%, 0.5W	289488	91637	CMF 5540102F	1		
R 419	RES, VAR, CERM, 100K, +-10%, 0.5W	369520	11236	360T-104A	1		
R 421	RES, CF, 4.3K, +-5%, 0.25W	441576	80031	CR251-4-5F4K3	1		
R 421	RES, VAR, CERM, 20K, +-10%, 0.5W	335760	11236	360T-203A	1		
RT 301	THERMISTOR, DISC, NEG., 10K, +-10%, 250	104596	73168	JA41J1	1		
TF 1-5	FIN, SINGLE, FWH, 0.025 SQ	267500	00779	87022-1	10		
TP 6-11	TEST POINT	512889	02640	62395	6		
U 101, 402	* IC, OP AMP, DUAL, JFET INPUT, 8 PIN DIP	495192	12040	LF353BN	2		
U 201	* MIXER, DOUBLE BALANCED, 1000 MHZ	525493	89536	525493	1		
U 301	* IC, CMOS, DUAL 8 BIT DAC, CURRENT OUTPUT	722272	89536	722272	1		
U 302, 311, 405	* IC, OP AMP, QUAD JFET INPUT, 14 PIN DIP	659748	89536	659748	3		
U 303	* IC, CMOS, 12 BIT MULTIPLYING DAC	722264	89536	722264	1		
U 304, 305, 308, 404	* IC, LSTTL, OCTAL D F/F, +EDG TRG, W/CLEAR	454892	01295	SN74LS273N	4		
U 306	* IC, LSTTL, QUAD 2 INPUT NAND LATE	393033	01295	SN74LS00N	1		
U 307	* IC, LSTTL, 3-B LINE DCDR W/ENABLE	407585	01295	SN74LS138N	1		
U 309, 310	* IC, COMPARATOR, QUAD, 14 PIN DIP	387233	12040	LM339N	2		
U 401	* IC, CMOS, QUAD BILATERAL SWITCH	408062	89536	408062	1		
U 403	* IC, CMOS, 10BIT DAC, 10BIT ACCUR, CUR OUT	507566	24355	AD7533LN	1		
W 1	CABLE ASSY, KF JUMPER	716993	89536	716993	1		
XU 101, 402	SOCKET, IC, 8 PIN	478016	91506	318-AG39D	2		
XU 301, 304, 405, 308, 404	SOCKET, IC, 20 PIN	454421	09922	D11820F-108	5		
XU 302, 306, 309, 310, 311, 401, 405	SOCKET, IC, 14 PIN	276527	09922	D1188F-108	7		
XU 303	SOCKET, IC, 18 PIN	418228	91506	318-AG39D	1		
XU 307, 403	SOCKET, IC, 16 PIN	276535	91506	318-AG39D	2		
Z 301	RES, NLI, SIF, 8 PIN, 7 RES, 10K, +-2%	412924	80031	95081002C1	1		
Z 401	RES, NET, CERM, CUSTOM	501841	89536	501841	1		

NOTE 1= ALSO INCLUDES XZ401
NOTE 2= ALSO INCLUDES XR144

THE FOLLOWING COMPONENTS ARE NON-FIELD REPLACEABLE:

- C202-206, 208, 209, 211, 212, 216-222, 224, 225, 252, 254, 263, 264, 271, 277
- CR126, 202-210
- L217, 220
- Q202, 204, 206, 215
- R203-206, 209-212, 214-217, 224-228, 253-256, 262-264
- U201

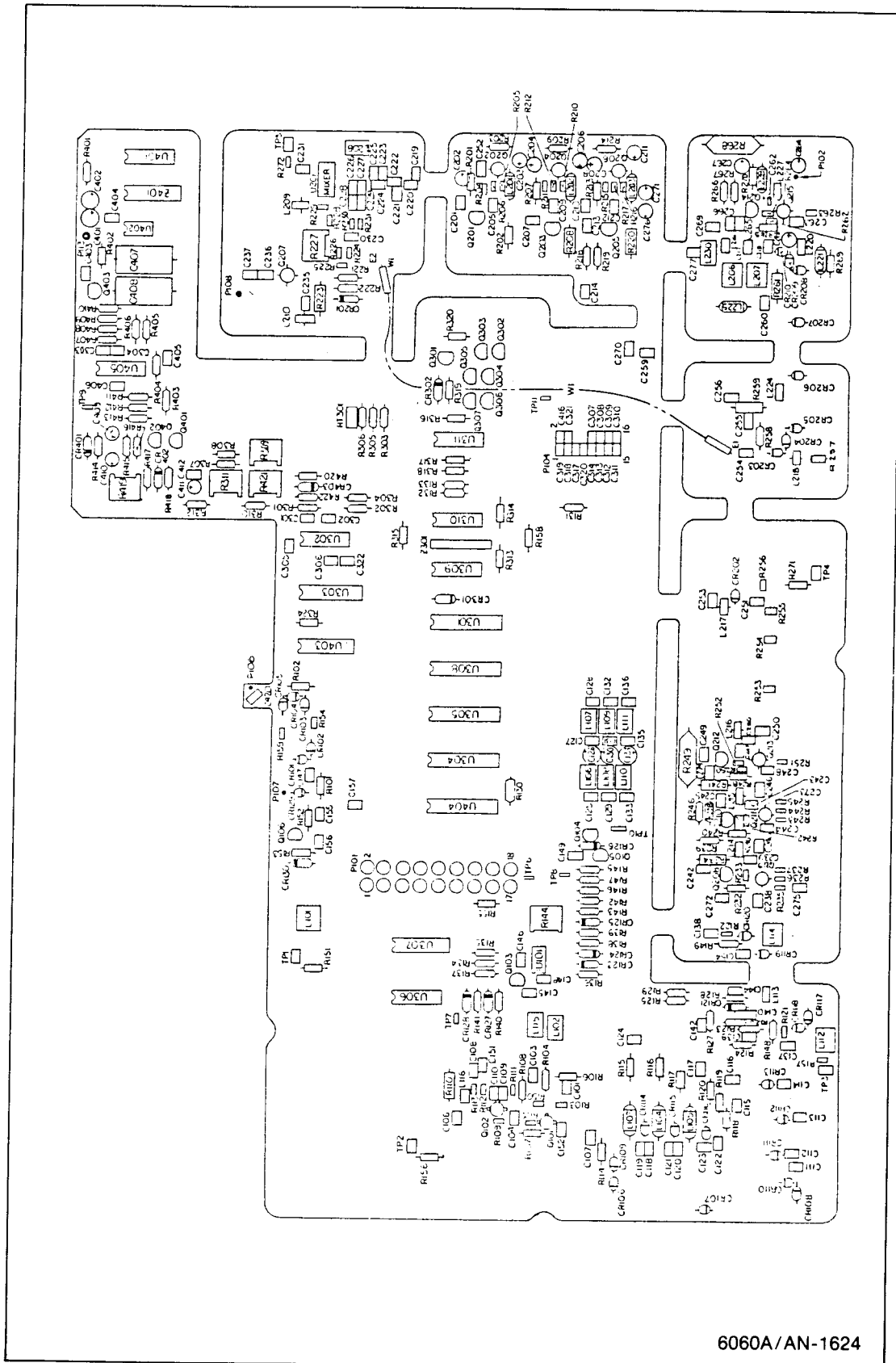

6060A/AN-1624

Figure 5-8. A2A4 Output PCA

LIST OF REPLACEABLE PARTS

TABLE 5-9. A2A5 ATTENUATOR/RFP ASSEMBLY
(SEE FIGURE 5-9.)

REFERENCE DESIGNATOR A->NUMERICS--> S	DESCRIPTION	FLUKE STOCK --NO--	MFRS SPLY CODE--	MANUFACTURERS PART NUMBER --OR GENERIC TYPE--	TOT QTY	R S -Q	N D Y -E
A 4	ATTENUATOR/RFP PCA	752667	89536	752667	1		
A 5	RELAY DRIVER/RFP PCA	752816	89536	752816	1		
FL 1	FILTER, RF, EYELET STYLE, 2000PF, BL	529495	89536	529495	11		
H 1	SCREW 6-32 X 3/4	376822	89536	376822	11		
H 2	SCREW 6-32 .50LG	320051	89536	320051	7		
H 3	SCREW 6-32 X 3/8	334458	89536	334458	3		
H 4	STANDOFF	423855	89536	423855	7		
MP 1	HOUSING, PLATED, ATTENUATOR, RELAYVERSN	717017	89536	717017	1	1	
U 26	IC, 2K X 8 EPROM	454603	01295	TMS2516JL	1		
W 24	CABLE ASSEMBLY, ATTENUATOR	752725	89536	752725	1		

1 NOTE 1 = UNPROGRAMMED PART

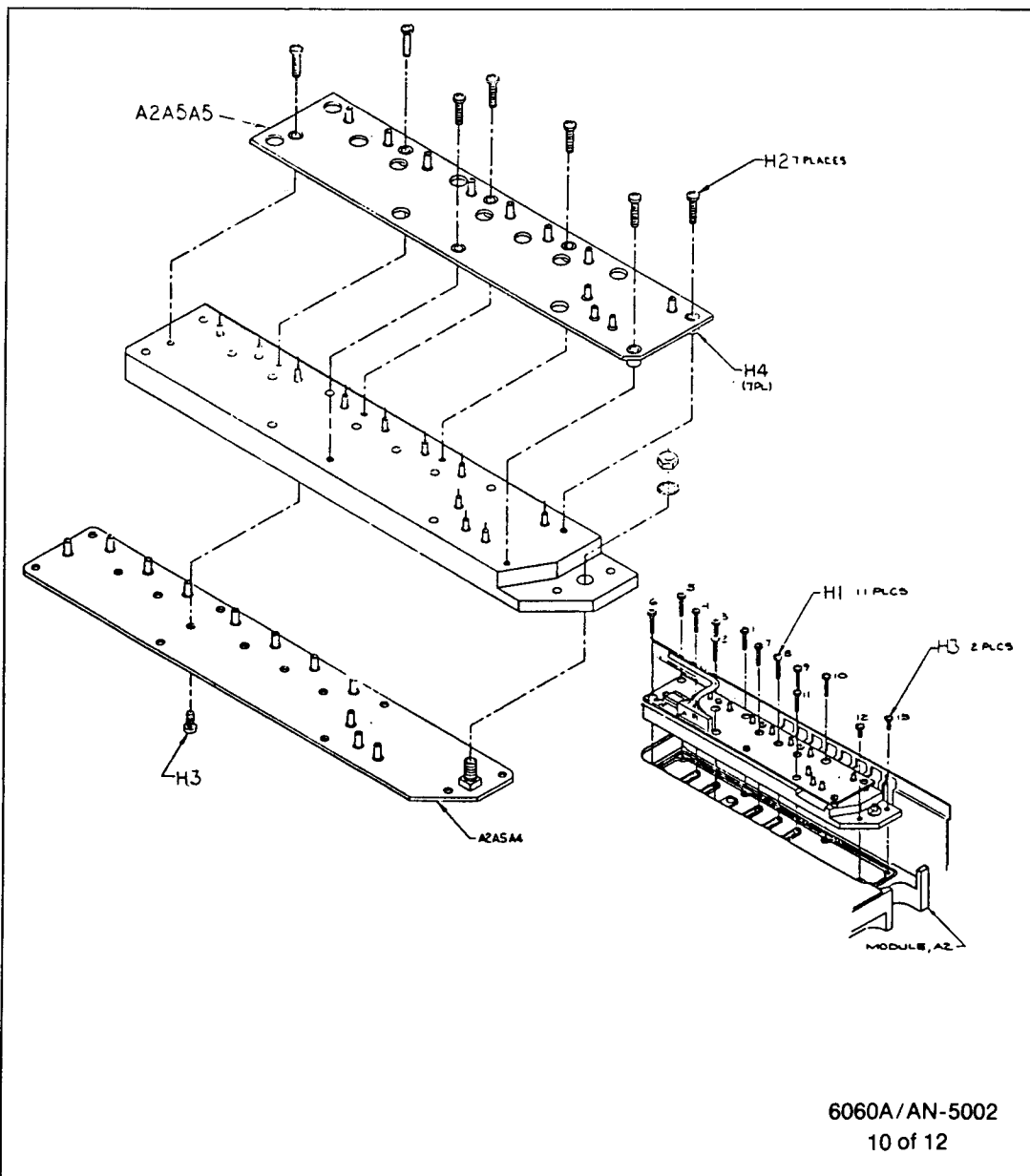

Figure 5-9. A2A5 Attenuator/RFP Assembly

LIST OF REPLACEABLE PARTS

TABLE 5-10. A2A5A4 ATTENUATOR/RPP PCA
(SEE FIGURE 5-10.)

REFERENCE DESIGNATOR A-NUMERIC(S)	DESCRIPTION	FLUKE STOCK --NO--	MFRS SPLY CODE	MANUFACTURERS PART NUMBER --OR GENERIC TYPE--	TOT QTY	R S -Q	N O T -E
C 1, 2, 4	CAP, CER, 1000PF, +-20%, 50V, X7R	514059	89536	514059	3		
C 3, 5	CAP, AL, 4.7UF, +-10%, 15V	519363	56289	193D475X9015C2	2		
C 6, 7	CAP, POLYEST, 0.1UF, +-20%, 50V	732883	89536	732883	2		
CR 1	DIODE, SI, SCHOTTKY BARRIER, SMALL SIGNAL	535195	28480	5082-2800	1	2	
CR 2- 9	DIODE, SI, BV= 70.0V, 500 MW	454181	03508	1N4606	8		
H 1	WASHER, SPRNG, COPPER, 0.316 ID	544239	89536	544239	8		
J 2	CONN, COAX, SMA, REC, PWB DR BLKHD	512087	16733	705147-001	1		
J 3	CONN, SOCKET, SPRING TYPE, .0690D, .143L	732826	89536	732826	1		
K 1- 8	RELAY, ARMATURE, 2 FORM C, 26.5VDC	528638	11532	712-26	8		
P 1- 11	CONN, SOCKET, PWB, 0.049 DIAMETER	544056	89536	544056	11		
R 1, 7, 10, 16, 19	RES, MF, 402, +-0.5%, 0.125W, 50PPM	461632	89536	461632	5		
R 2, 3, 8, 9, 11, 12, 17, 18, 20, 21	RES, MF, 56.9, +-0.5%, 0.125W, 50PPM	461590	89536	461590	10		
R 4	RES, MF, 94.2, +-0.5%, 0.125W, 50PPM	461616	89536	461616	1		
R 5, 6	RES, MF, 83.5, +-0.5%, 0.125W, 50PPM	461608	89536	461608	2		
R 13	RES, MF, 37.4, +-0.5%, 0.125W, 50PPM	461079	89536	461079	1	1	
R 14, 15	RES, MF, 150, +-0.5%, 0.125W, 50PPM	461624	89536	461624	2		
R 22	RES, CC, 10K, +-5%, 0.125W	643940	01121	BB1035	1		

ALL COMPONENTS NON FIELD REPLACEABLE

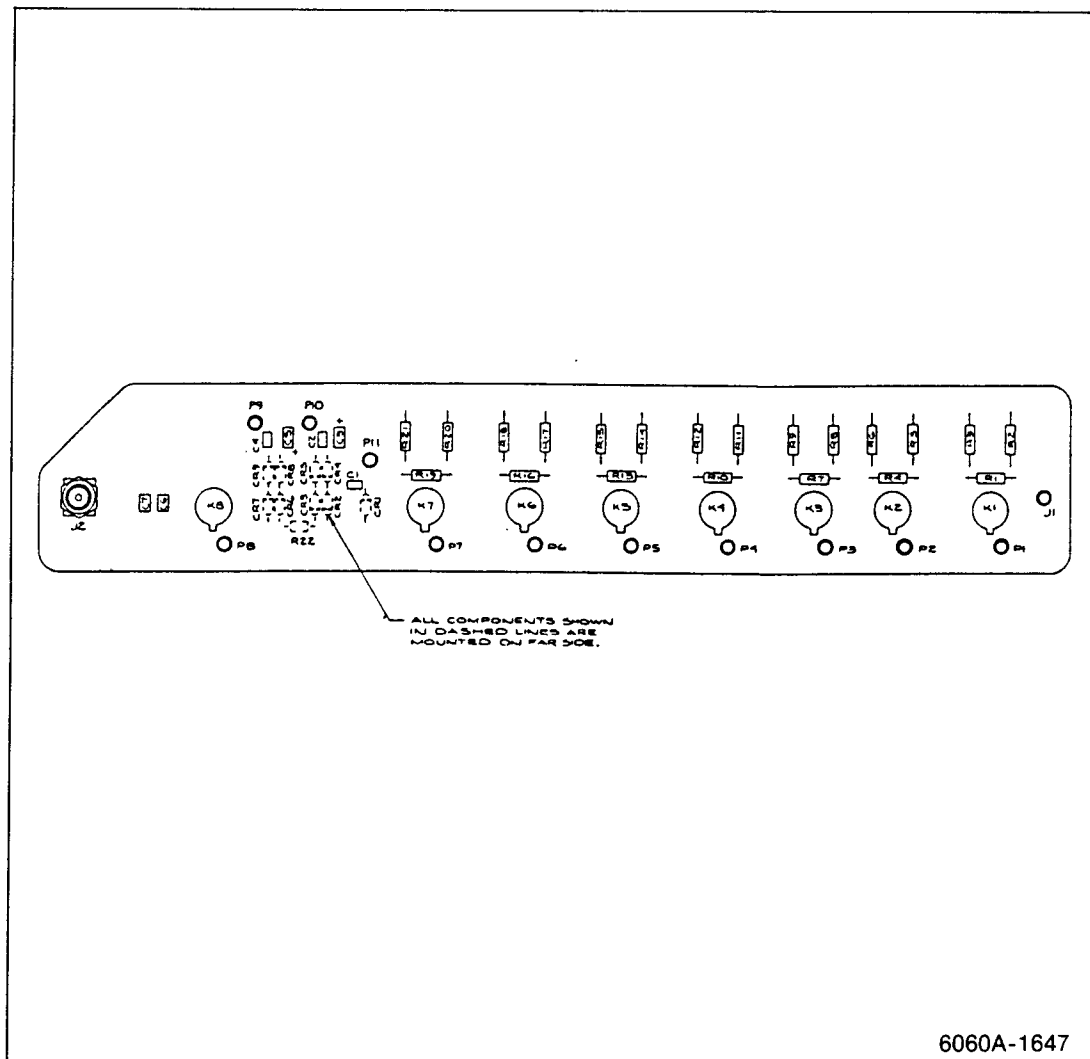

Figure 5-10. A2A5A4 Attenuator/RPP PCA

LIST OF REPLACEABLE PARTS

TABLE 5-11. A2A5A5 RELAY DRIVER/RPP CONTROLLER PCA
(SEE FIGURE 5-11.)

REFERENCE DESIGNATION	DESCRIPTION	FUJIK	FLUKE STOCK	HELS SPLY CODE	MANUFACTURERS PART NUMBER OR GENERIC TYPE	QTY	R S T Q E
C 7, 11	CAP, POLY, 5, 0.1UF, +20%, 50V	737883	89536	732883		8	
C 8, 9, 12	CAP, CER, 0.01UF, +20%, 100V, X7R	407361	72982	8121-A100-W5R-103M		4	
C 13		407361					
C 10, 16	CAP, CER, 0.22UF, +20%, 50V, Z5U	519157	51406	RFE11125U224R50V		2	
C 14	CAP, AL, 22UF, +50%, 20%, 35V	436040	89536	436040		1	
C 15	ELECTRO, MIN, LO LEAK, 4.7M, 35V	603993	89536	603993		1	
CR 11, 14, 16, 17	* DIODE, SI, BV=75.0V, IO=150MA, 500 MW	203333	07910	1N4448		6	1
J 1, 11	SOCKET, SINGLE, PWB, FOR 1042, 1049 PIN	544056	89536	544056		11	
L 1, 10	CHUKE, 2TORN	320911	89536	320911		10	
L 11	INDUCTOR, 20UH, +10%, 14 MHZ, SHIELDED	542290	89536	542290		1	
L 12, 13	INDUCTOR, 47 OH, +25%, 26.5 MHZ, SHIELDED	147850	72259	WEE 47		2	2
MF 1	PWB, RELAY DRIVER/RPP CONTROLLER	717025	89536	717025		1	
Q 1, 7, 9	* TRANSISTOR, SI, NPN, SMALL SIGNAL	416707	04713	MF55656J		8	1
Q 8	* TRANSISTOR, SI, NPN, SMALL SIGNAL	330803	07263	MF55660		1	1
R 1, 4, 7, 10, 13, 16, 19, 38	RES, CF, 510, +5%, 0.25W	441600	80031	CR251-4-5F510E		8	1
R 2, 5, 8, 11, 14, 17, 20, 39, 41	RES, CF, 4.7K, +5%, 0.25W	348821	01121	CB4725		9	
R 3, 6, 9, 12, 15, 18, 21, 40	RES, CF, 1, +5%, 0.25W	357665	80031	CR251-4-5F1E		8	
R 22, 23, 29, 35, 36, 42, 45	RES, CF, 1K, +5%, 0.25W	343426	80031	CR251-4-5F1K		7	
R 24	RES, CF, 30K, +5%, 0.25W	368753	80031	CR251-4-5F30K		1	
R 25, 30, 31, 37	RES, CF, 10K, +5%, 0.25W	348839	80031	CR251-4-5F10K		4	
R 27	RES, MF, 1.07K, +1%, 0.125W, 100PFM	344325	89536	344325		1	
R 28	RES, MF, 422, +1%, 0.125W, 100PFM	288506	91637	CMF554220F		1	
R 32	RES, MF, 1.5K, +1%, 0.125W, 100PFM	313098	91637	CMF551501F		1	
R 33	RES, CF, 56, +5%, 0.25W	342618	80031	CR251-4-5F56L		1	
R 34	RES, CF, 100K, +5%, 0.25W	348920	80031	CR251-4-5F100K		1	
R 43	RES, CF, 13K, +5%, 0.25W	441402	80031	CR251-4-5F13K		1	
R 44	RES, CF, 2K, +5%, 0.25W	441469	80031	CR251-4-5F2K		1	
R 46	RES, CF, 470, +5%, 0.25W	343434	80031	CR251-4-5F470E		1	
R 47	RES, CF, 12K, +5%, 0.25W	348847	80031	CR251-4-5F12K		1	
R 48	RES, CF, 4.3K, +5%, 0.25W	441576	80031	CR251-4-5F4K3		1	
TF 1	PIN, SINGLE, PWB, 0.025 SU	267500	00779	87022-1		20	1
U 1	* IC, OP AMP, QUAD, JFET INPUT, TO-5 CASE	483438	89536	483438		1	1
VR 1, 7, 15	* ZENER, UNCOMP, 30.0V, 10%, 4.2MA, 0.4W	272633	04713	1N972A		8	
VR 8, 9, 18	* ZENER, UNCOMP, 4.7V, 5%, 20.0MA, 0.4W	524058	14552	1N751		3	2
VR 10	* ZENER, COMP, 6.4V, 5%, 1 PFM TO, 2.0MA	381988	89536	381988		1	2
XU 2	SOCKET, IC, 24 PIN	376236	91506	324-AG19D		1	

ALL COMPONENTS ARE NON-FIELD REPLACEABLE

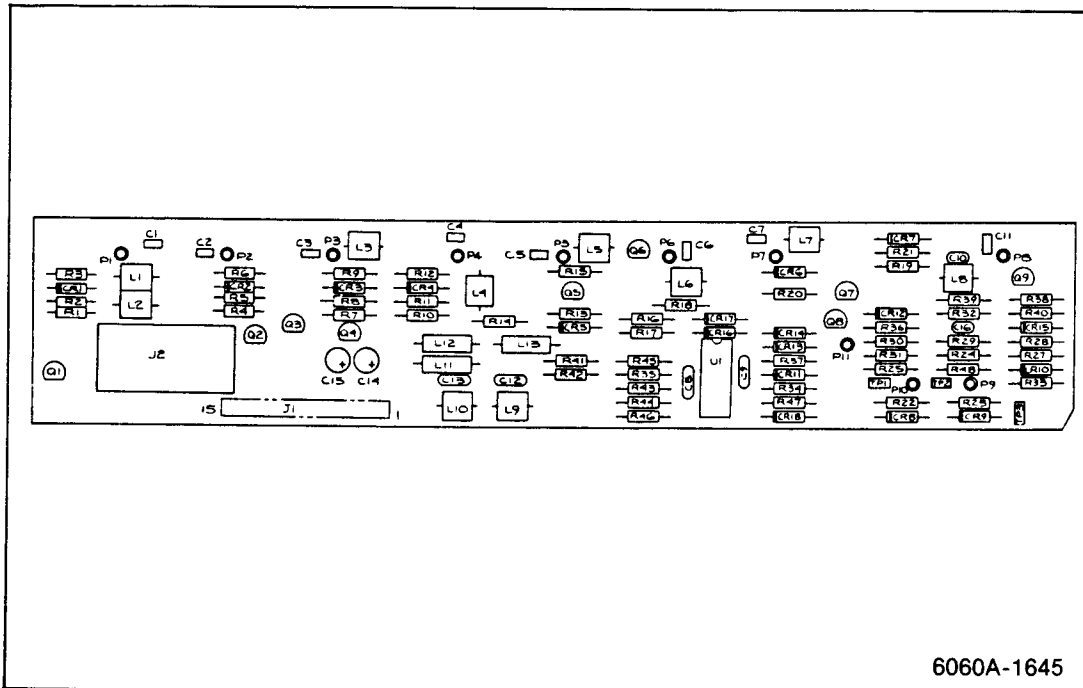

6060A-1645

Figure 5-11. A2A5A5 Relay Driver/RPP Controller PCA

LIST OF REPLACEABLE PARTS

TABLE 5-12. A2A7 CONTROLLEN PCA
(SEE FIGURE 5-12.)

REFERENCE DESIGNATION	DESCRIPTION	FLUKE STOCK	MFGS SPLY NO	MANUFACTURERS PART NUMBER OR GENERIC TYPE	QTY	R S T	N O T E
C 1	CAP. AL, 470F, +50-20%, 16V	436006	62643	SM/VB	1		
C 2, 3, 7,	CAP. POLYEST, 0.220F, +10%, 50V	696492	89536	696492	26		
C 10, 13, 16,		696492					
C 18, 19, 21,		696492					
C 23, 25, 28		696492					
C 31, 34, 35,		696492					
C 39, 42, 44,		696492					
C 45		696492					
C 3	CAP. TA, 0.470F, +20%, 35V	161349	56349	196D474X0035HA1	1		
C 4, 5	CAP. TA, 100F, +20%, 20V	330662	56289	196D100X0020KA1	2		
C 22, 51, 53	CAP. CER, 220FF, +10%, 1000V, 25F	368605	89536	368605	7		
C 57		368605					
C 50, 52, 58,	CAP. CER, 2000FF, +100-0%, 1000V, 25U	105569	71590	DA140-139CB	4		
C 59		105569					
C 60	CAP. CER, 100FF, +10%, 1000V, 33N	105593	71590	DD-101	1		
C 61	CAP. CER, 56FF, +20%, 100V, 00G	512970	51406	RPE121	1		
CR 1	* DIODE, SI, BV= 75.0V, IO=150MA, 500 MW	203323	07910	1N4448	1	1	
J 101, 105, 107	FIN, SINGLE, FWB, 0.025 SQ	267500	00779	87022-1	53		
J 102	FIN, SINGLE, FWB, 0.025 SQ	649681	00779	3-87022-2	32		
J 106	HEADER, 2 ROW, 0.100CTR, RT ANG, 26 PIN	512590	89536	512590	1		
L 1, 2	CHOKO, 6TURN	320911	89536	320911	2	1	
L 3	INDUCTOR, 4.7 OH, +/-10%, 72 MHZ, SHLDED	174722	72259	WEE4K7	1		
MF 1	FWB, CONTROLLER	774133	89536	774133	1	1	
F 101	SOCKET, SINGLE, FWB, FOR .042-.049 PIN	544056	89536	544056	18		
R 1, 3, 11	RES. CF, 190, +/-5%, 0.25W	441436	80031	CR251-4-5P180E	7		
R 2, 13	RES. CF, 4.7K, +/-5%, 0.25W	348821	81121	CB4725	2		
R 3	RES. CF, 20K, +/-5%, 0.25W	441477	80031	CR251-4-5P20K	1		
R 4	RES. CF, 390K, +/-5%, 0.25W	442425	80031	CR251-4-5P390K	1		
R 5	RES. CF, 100K, +/-5%, 0.25W	348920	80031	CR251-4-5P100K	1		
R 12	RES. CF, 100, +/-5%, 0.25W	348771	80031	CR251-4-5P100E	1		
R 14, 15	RES. CF, 1.3K, +/-5%, 0.25W	441394	80031	CR251-4-5P1K3	2		
U 1	* IC, NMOS, 16 BIT MICROCOMPUTER	640417	01295	1MS9995N	1		
U 2	* IC, LSTTL, HEX BUFFER W/NOR ENABLE	483800	01295	SN74LS367N	1	1	
U 3, 4, 18	* IC, LSTTL, OCTAL BUS TRNSVR W/3-ST OUT	477406	01295	SN74LS245N	3	1	
U 5, 44	* IC, LSTTL, HEX INVERTER	393058	01295	SN74LS04N	2	1	
U 7	* IC, COMPARATOR, DUAL, LO FWR, 8 PIN DIP	478354	12040	LM393N	1	1	
U 8	* IC, LSTTL, TRIPLE 3 INPUT NAND GATE	393074	01295	SN74LS10N	1	1	
U 9	* IC, LSTTL, HEX D F/F, +EDG TRG, W/CLEAR	393207	01295	SN74LS174N	1	1	
U 10	* IC, STTL, QUAD 2 INPUT OR GATE	604629	01295	SN74S32N	1	1	
U 11, 40	* IC, LSTTL, OCTAL D TRANSPARENT LATCHES	504514	01295	SN74LS373N	2	1	
U 14	* IC, LSTTL, 2-4 LINE DEMUX	393165	01295	SN74LS139N	1	1	
U 15, 16, 33,	* IC, LSTTL, OCTAL LINE DRVR W/3-STATE OUT	429035	01295	SN74LS244N	4	1	
U 34	*	429035					
U 17, 27	* IC, LSTTL, OCTAL D F/F, +EDG TRG, W/CLEAR	454892	01295	SN74LS273N	2	1	
U 20, 35, 36,	* IC, LSTTL, 3-8 LINE DCDR W/ENABLE	407585	01295	SN74LS138N	4	1	
U 38	*	407585					
U 22	* PROGRAMMED EPROM 27128	774406	89536	774406	1		
U 21	* PROGRAMMED EPROM 27256	774414	89536	774414	1		
U 25	* IC, 2K X 8 STAT RAM	584144	33297	67D4016C-2	1	1	
U 30, 31	* IC, ARRAY, 7 TRANS, NPN, DARLINGTON PAIRS	454116	01295	ULN2003	2		
U 37	* IC, LSTTL, QUAD 2 INPUT OR GATE	393108	01295	SN74LS32N	1	1	
U 42	* IC, LSTTL, DUAL JK F/F, +EDG TRIG	414029	01295	SN74LS112N	1	1	
XU 1	SOCKET, IC, 40 PIN	429282	09922	D11B40P-108	1		
XU 2, 9, 14,	SOCKET, IC, 16 PIN	276535	91506	316-AG39D	2		
XU 20, 30, 31,		276535					
XU 35, 36, 38,		276535					
XU 42		276535					
XU 21, 22	SOCKET, IC, 28 PIN	448217	91506	328-AG39D	2		
XU 25	SOCKET, IC, 24 PIN	376236	91506	324-AG39D	4		
Y 41	* CRYSTAL, 10MHZ, +/-0.01%, HC 18/U	520239	89536	520239	1	1	
Z 1	RES. NET, STP, 10 PIN, 9 RES, 4.7K, +/-2%	484063	80031	95081002CL	1		
Z 2-5	RES. NET, STP, 10 PIN, 9 RES, 10K, +/-2%	414003	80031	95081002CL	4		

NOTE

- U23 EPROM PART OF A2A2
- U24 EPROM PART OF A2A4
- U26 EPROM PART OF A2A5

LIST OF REPLACEABLE PARTS

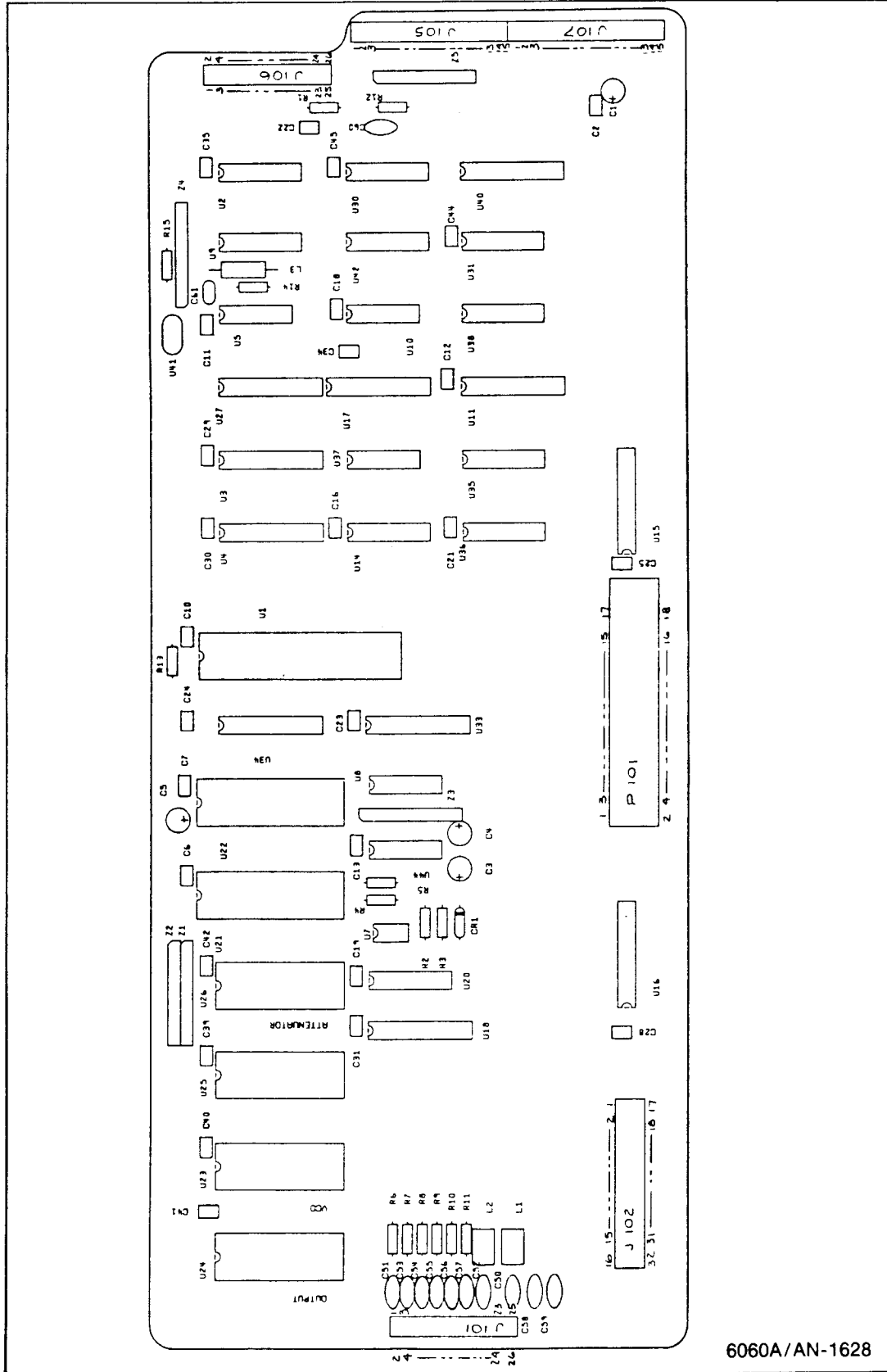

Figure 5-12. A2A7 Controller PCA

LIST OF REPLACEABLE PARTS

TABLE 5-13. A5A1 POWER SUPPLY PCA
(SEE FIGURE 5-13.)

REFERENCE DESIGNATOR	DESCRIPTION	FLUKE STOCK NO.	MFRS SPLY CODE	MANUFACTURERS PART NUMBER OR GENERIC TYPE	QTY	NO. OF	NO. OF
A - NUMERICS	S					Q	E
C 1	CAP, AL, 2200UF, +30-10%, 35V	715334	89536	715334	1		
C 2, 5	CAP, AL, 10000UF, +30-20%, 35V	614990	89536	614990	2		
C 3, 6, 12	CAP, CER, 0.1UF, +-20%, 50V, X7R	573808	72892	8131-050-W5R100NFM	3		
C 4, 7, 15, 20	CAP, TA, 6.8UF, +-20%, 35V	363713	56289	196D685X0035KA1	4		
C 8	CAP, AL, 15000UF, +30-10%, 25V	732958	89536	732958	1		
C 9, 21, 22	CAP, TA, 2.2UF, +-20%, 20V	161927	56289	196D225X0020HA1	3		
C 10	CAP, TA, 22UF, +-20%, 15V	423012	56289	196D226X0015KA1	1		
C 11	CAP, AL, 470UF, +30-20%, 80V	574160	62643	NM	1		
C 13, 14	CAP, TA, 4.7UF, +-20%, 50V	363721	56289	196D475XY015HA1	2		
C 16-19	CAP, FOLYS, 0.22UF, +-10%, 100V	436113	73445	C280MAH1A220K	4	1	
CR 1, 2, 6	* DIODE, SI, RECT, BRIDGE, BV=200V, IO=1.0A	296509	09423	FB200	3	1	
CR 3, 4, 8	* DIODE, SI, 100 PIV, 1.0 AMP	343491	01295	1N4002	3		
CR 5	DIODE, SI, 45PIV, 7.5A, DUAL SCHOTTKY	741322	89536	741322	1		
CR 6	* THYRISTOR, SI, TRIAC, VBO=200V, B.OA	413013	02735	T2800B	1		
CR 9, 10	* ZENER, UNCOMP, 62.0V, 5%, 20MA, 5.0W	559567	89536	559567	2	1	
H 42	SCREW, MACH, PHF SEMS, STL, 4-40X1/4	185918	89536	185918	1		
H 43	NUT, MACH, HEX, STL, 4-40	110635	89536	110635	1		
J 1	HEADER, 1 ROW, 0.156CTR, 12 PIN	512160	27264	09-80-1123	1		
J 2	HEADER, 1 ROW, 0.156CTR, 5 PIN	512186	27264	09-80-1053	1	1	
J 3-6	PIN, SINGLE, PWB, 0.025 SQ	267500	00779	87022-1	39		
MP 1	HEAT SINK, 10-220	524934	13103	6025B-1T	1	1	
R 1	RES, MF, 249, +-1%, 0.125W, 100PFM	168203	91637	CMF55249F	1		
R 2	RES, MF, 6.65K, +-1%, 0.125W, 100PFM	294918	91637	CMF551272F	1		
R 3	RES, VAR, CERAM, 1K, +-10%, 0.5W	285155	71450	360S102A	1		
R 4	RES, CF, 10K, +-5%, 0.25W	348839	80031	CR251-4-5F10K	1		
R 6-9	RES, CF, 5.1, +-5%, 0.25W	441287	80031	CR251-4-5F5R1	4		
R 10, 13	RES, CF, 220, +-5%, 0.25W	342626	80031	CR251-4-5F220E	2		
R 11	RES, CF, 1, +-5%, 0.25W	357665	80031	CR251-4-5F1E	1		
R 12	RES, CF, 0.51, +-5%, 0.25W	381954	80031	CR251-4-5F0R5E	1		
S 1	SWITCH, SLIDE, DPDT	452862	89536	452862	1	1	
TF 1-11	TEST POINT	512889	02660	62395	16		
VR 7	* ZENER, UNCOMP, 6.2V, 5%, 20.0MA, 0.4W	325811	07910	1N753A	1	1	

NOTE
U1,2,4,5 LISTED IN TABLE 5-4 (A3)

LIST OF REPLACEABLE PARTS

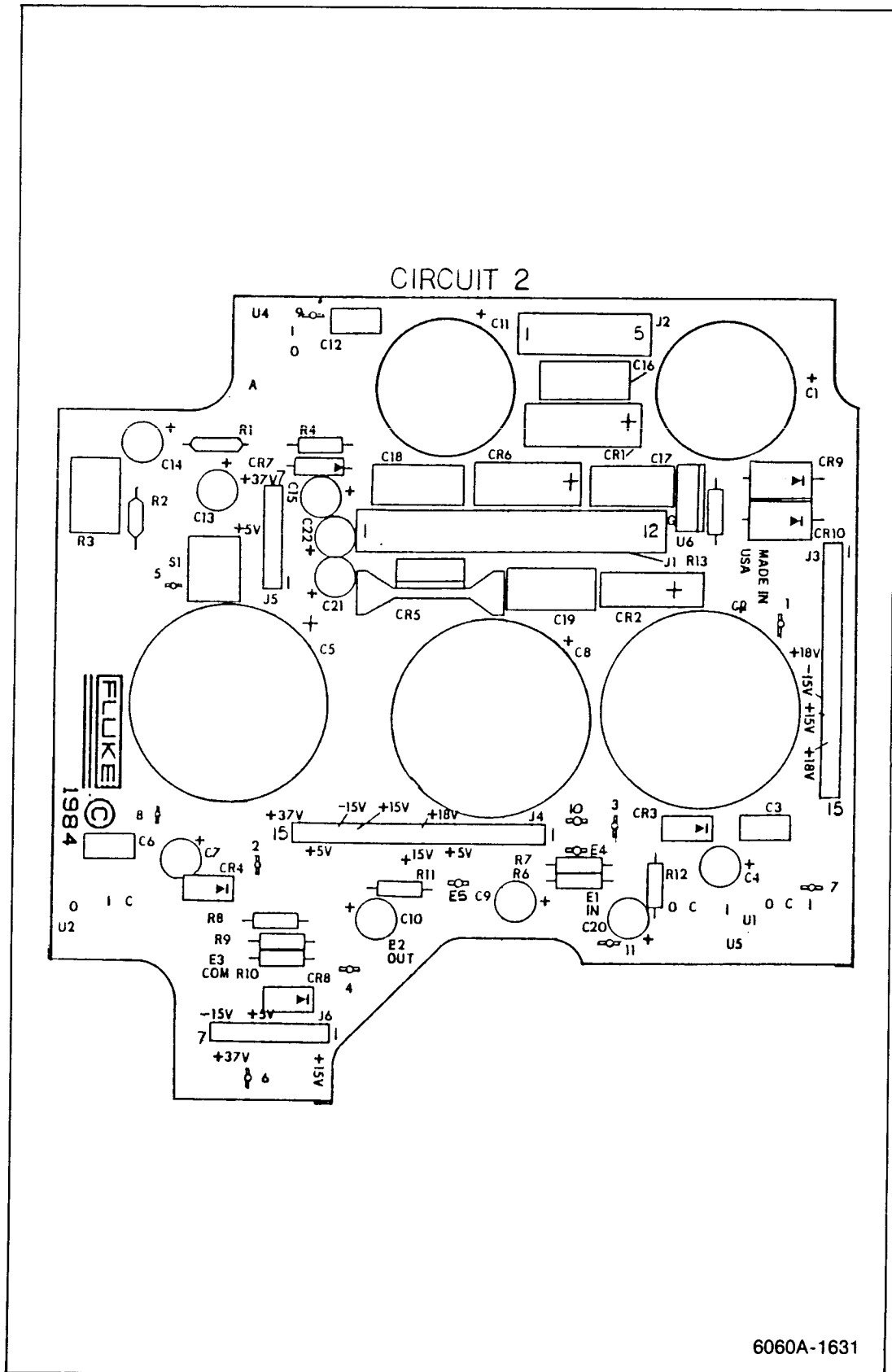

Figure 5-13. A3A1 Power Supply PCA

LIST OF REPLACEABLE PARTS

TABLE 5-14. A3A3A1 IEEE-488 INTERFACE PCA
(SEE FIGURE 5-14.)

REFERENCE DESIGNATOR	QTY	DESCRIPTION	FLUKE STOCK NO	MFRS SPLY CODE	MANUFACTURERS PART NUMBER OR GENERIC TYPE	QTY	ROTS
C 1-4, 6, 7, 9-11	9	CAP, POLYEST, 0.22UF, +/-10%, 50V	696492	89536	696492		
J 1	1	CONNECTOR	658039	89536	658039		
L 1-3	3	CHOKER, 6TURN	320911	89536	320911		
P 1	1	SOCKET	543512	89536	543512		
R 1	1	RES, CH, 1K, +/-5%, 0.25W	343426	80031	CR251-4-5F1K		
S 1	1	SWITCH	658567	89536	658567		
U 3, 4	2	* IC, 16 BIT, OCTAL IEEE 488 BUS TRANSVR	524835	04713	MC3447F		1
U 6	1	* IC, 16 BIT, OCTAL D TRANSPARENT LATCHES	504514	01295	SN74LS373N		1
U 7	1	* IC, 16 BIT, OCTAL BUS TRANSVR W/3-ST OUT	477406	01295	SN74LS245N		1
U 8	1	* IC, TTL, QUAD 2 INPUT AND GATE	393066	01295	SN74LS08N		1
XU 1	1	SOCKET, IC, 40 PIN	429282	09922	DILB40P-108		1
Z 1-4	4	RES, NET, SIF, 10 PIN, 9 RES, 10K, +/-2%	414003	80031	95081002CL		1

LIST OF REPLACEABLE PARTS

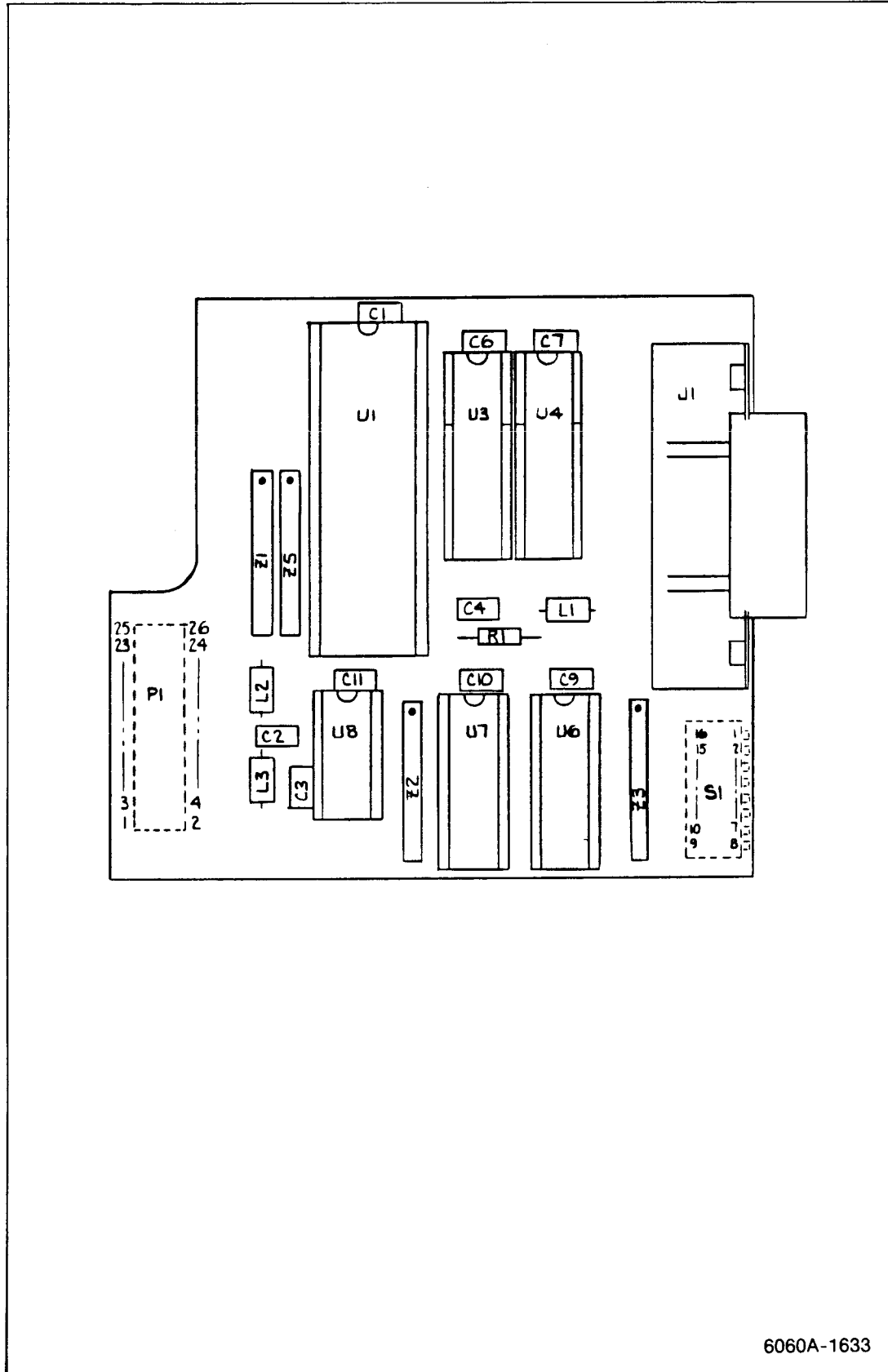
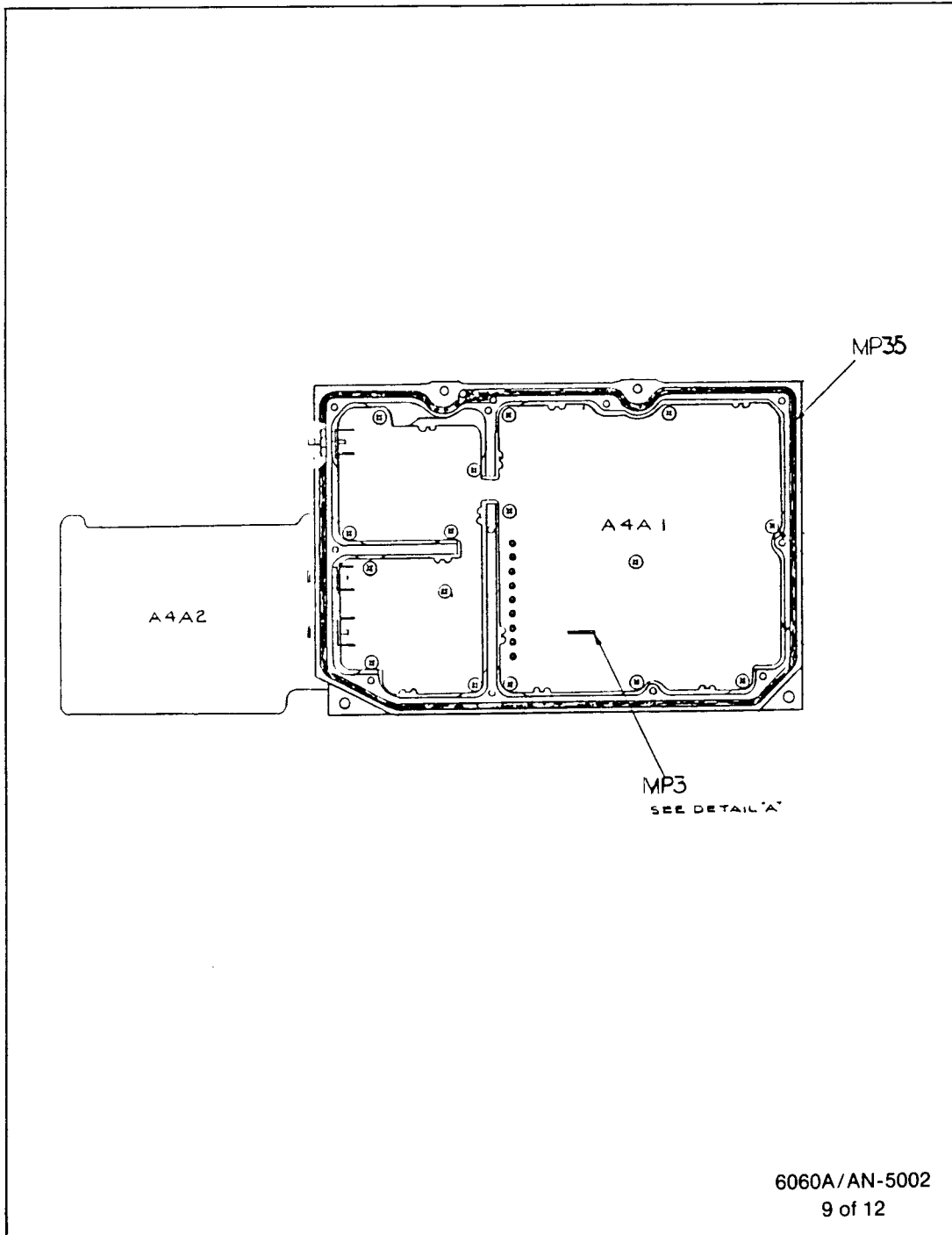

Figure 5-14. A3A3A1 IEEE-488 Interface PCA

LIST OF REPLACEABLE PARTS

TABLE 5-15. A4 METER MODULE ASSEMBLY
(SEE FIGURE 5-15.)

REFERENCE DESIGNATOR	QTY	DESCRIPTION	FLUKE STOCK NO	MFRS SPLY CODE	MANUFACTURERS PART NUMBER --OR GENERIC TYPE--	TOT QTY	R S T	N O T -E
A 1	1	DISCRIMINATOR PCA	774265	89536	774265	1		
A 2	1	ANALOG/DIGITAL PCA	774257	89536	774257	1		
H 1	1	SCREWS	772236	89536	772236	20		
MP 35	2	GASKET, SHIELDING, HONEL MESH, CIRCULAR	720664	89536	720664	2		
MP 36	1	AIDE, PCB FULL	541730	89536	541730	1		



6060A/AN-5002
9 of 12

Figure 5-15. A4 Meter Module Assembly

LIST OF REPLACEABLE PARTS

TABLE 5-16. 4441 DISCRIMINATOR PCA
(SEE FIGURE 5-16.)

REFERENCE DESIGNATOR A->NUMERIC(S)->>>	S	DESCRIPTION	FLUKE STOCK --NO--	MFRS SPLY CODE--	MANUFACTURERS PART NUMBER --OR GENERIC TYPE--	TOT QTY	R S -Q	O T -E
C 1		CAP, CER, 270PF, +-5%, 100V, COG	614586	89536	614586	1		
C 2		CAP, CER, 1000PF, +-5%, 50V, COG	528539	51406	RFE113	1		
C 3		CAP, CER, 2200PF, +-20%, 100V, X7R	358291	89536	358291	1		
C 4, 5, 15-		CAP, POLYEST, 0.1UF, +-20%, 50V	732883	89536	732883	20		
C 17, 20- 22,			732883					
C 25, 26, 30,			732883					
C 31, 35- 38,			732883					
C 40, 41, 48,			732883					
C 49			732883					
C 6- 8, 11,		CAP, AL, 47UF, +50-20%, 16V	436006	62643	SH/VB	5		
C 47			436006					
C 9, 10		CAP, CER, 33FF, +-2%, 50V, COG	354052	72982	8121-A100-COG-330G	2		
C 12, 13, 53		CAP, CER, 120PF, +-2%, 100V, COG	543819	04222	SR15	3		
C 14		CAP, CER, 150PF, +-2%, 100V, COG	512988	89536	512988	1		
C 18, 19, 50		CAP, POLYEST, 0.47UF, +-10%, 50V	697409	89536	697409	3		
C 23		CAP, POLYEST, 0.22UF, +-10%, 50V	696492	89536	696492	1		
C 24, 42		CAP, CER, 330PF, +-5%, 100V, COG	528620	51406	RFE121	2		
C 27		CAP, POLYEST, 1UF, +-10%, 50V	271619	84411	X463UW1029, 50W	1		
C 28, 29, 54		CAP, CER, 100PF, +-5%, 100V, COG	512848	51406	RFE121	3		
C 32, 33		CAP, CER, 750PF, +-5%, 50V, COG	528521	89536	528521	2		
C 34		CAP, AL, 2.2UF, +-20%, 50V	614875	89536	614875	1		
C 39		ELECTRO, MIN, LO LEAK, 4.7MF, 35V	603993	89536	603993	1		
C 51		CAP, CER, 2700PF, +-20%, 100V, X7R	362889	89536	362889	1		
C 52		CAP, CER, 56PF, +-2%, 100V, COG	512970	51406	RFE121	1		
CR 1- 5, 12	*	DIODE, SI, BV= 75.0V, IO=150MA, 500 MW	203323	07910	1N4448	6		1
CR 6- 9	*	DIODE, SI, SCHOTTKY BARRIER, SMALL SIGNAL	313247	28484	HF5082-6264	4		2
CR 18	*	ZENER UNCOMP, 10.0V, 5%, 12.5MA, 0.4W	246611	07910	1N9618	1		
DS 1	*	LED, RED, PCB MOUNT, LUM INT=1.3MCD	385914	09214	SSL-22	1		1
H 1		WASHER, SPRNG, LUMPER, 0.316 ID	544239	89536	544239	1		
H 37		SCREW, MACH, PHNO, S. STL, 6-32X9/32	544122	89536	544122	21		
J 1, 2		CONN, COAX, SMA(M), FWB OR PANEL	512087	16733	705147-001	2		
J 3		CONN, COAX, SMB(M), FWB OR PANEL	512095	16733	702033	1		
K 1		RELAY, ARMATURE, 2 FORM C, 26.5VDC	528638	11532	712-26	1		
L 1		INDUCTOR, 1.5UH, +/-5%, 128 MHZ, SHLDED	413856	89536	413856	1		
L 2		INDUCTOR, 2.7 UH, +/-10%, 96MHZ, SHLDED	320978	24759	MR2.7	1		
L 3		CHOKO, 6TURN	320911	89536	320911	1		
L 5, 6		INDUCTOR, 0.47 UH, +/-10%, 264MHZ, SHLDED	320929	24759	MR0.47	2		
L 7		INDUCTOR, 3.9 UH, +/-5%, 84 MHZ, SHLDED	413864	89536	413864	1		
L 9, 11		INDUCTOR, 0.12UH, +/-10%, UNSHIELDED	772954	89536	772954	2		
L 10		INDUCTOR, 0.18UH, +/-10%, UNSHIELDED	772962	89536	772962	1		
MF 1		BRACKET, SMA (CHEM-EICH)	774182	89536	774182	3		
P 1		SOCKET, SINGLE, FWB, FOR .042-.049 PIN	544056	89536	544056	9		
Q 1, 2	*	TRANSISTOR, SI, N-DNOS FE1, 10-72	477229	18324	SD213EE	2		1
Q 3, 4	*	TRANSISTOR, SI, PNP, HI-SPEED SWITCH	369629	07263	543576	2		1
Q 5- 7, 9,	*	TRANSISTOR, SI, NPN, SMALL SIGNAL	218396	04713	2N3904	5		1
Q 10	*		218396					
Q 8	*	TRANSISTOR, SI, PNP, SMALL SIGNAL	418707	04713	MFS562	1		1
R 1, 46		RES, CF, 51, +-5%, 0.25W	414540	80031	CR251-4-5F51E	2		
R 2, 57		RES, CF, 10K, +-5%, 0.25W	348839	80031	CR251-4-5F10K	2		
R 3		RES, MF, 100, +-1%, 0.125W, 100FFM	168195	91637	CHF55100F	2		
R 4, 22		RES, MF, 1K, +-1%, 0.125W, 100FFM	168229	91637	CHF551001F	2		
R 5, 6		RES, MF, 215, +-1%, 0.125W, 100FFM	343533	91637	CHF552150F	2		
R 7, 26, 27,		RES, CF, 1K, +-5%, 0.25W	343426	80031	CR251-4-5F1K	5		
R 45, 59			343426					
R 8, 51, 56		RES, CF, 100, +-5%, 0.25W	348771	80031	CR251-4-5F100E	3		
R 9, 10		RES, MF, 5.49K, +-1%, 0.125W, 100PPM	334565	91637	CHF55491F	2		
R 11, 12		RES, MF, 11K, +-1%, 0.125W, 100PPM	293621	91637	CHF55	2		
R 13, 14		RES, CF, 36K, +-5%, 0.25W	442392	80031	CR251-4-5F36K	2		
R 15		RES, MF, 11.8K, +-1%, 0.125W, 100PPM	293647	89536	293647	1		
R 16		RES, CF, 15K, +-5%, 0.25W	348854	80031	CR251-4-5F15K	1		
R 17		RES, MF, 750, +-1%, 0.125W, 100PPM	312801	91637	CHF557500F	1		
R 18, 23		RES, CF, 51K, +-5%, 0.25W	376434	80031	CR251-4-5F51K	2		
R 19, 24		RES, CF, 100K, +-5%, 0.25W	348820	80031	CR251-4-5F100K	2		
R 20		RES, CF, 3.3K, +-5%, 0.25W	348813	80031	CR251-4-5F3K3	1		
R 21		RES, CF, 1.5K, +-5%, 0.25W	343418	80031	CR251-4-5F1K5	1		
R 25		RES, MF, 100K, +-1%, 0.125W, 100PPM	248807	91637	CHF551003F	1		
R 28, 50, 54		RES, CF, 4.7K, +-5%, 0.25W	348821	01121	CR4725	3		
R 29		RES, VAR, CERM, 5K, +-10%, 0.5W	327569	11236	3601-502A	1		
R 30		RES, VAR, CERM, 10K, +-10%, 0.5W	485458	32997	3299W-CR2-103	1		
R 31		RES, VAR, CERM, 100, +-10%, 0.5W	275735	11236	3601-101A	1		
R 32		RES, VAR, CERM, 200, +-10%, 0.5W	275743	89536	275743	1		
R 33, 37		RES, CF, 91, +-5%, 0.25W	441683	80031	CR251-4-5F91E	2		
R 34- 36, 38		RES, CF, 82, +-5%, 0.25W	442277	80031	CR251-4-5F82E	4		
R 39, 48		RES, CF, 200, +-5%, 0.25W	441451	80031	CR251-4-5P200E	2		
R 40		RES, CC, 51, +-5%, 0.125W	266262	01121	RR5105	1		
R 41, 43		RES, CF, 150, +-5%, 0.25W	343442	80031	CR251-4-5F150	2		
R 42		RES, CF, 39, +-5%, 0.25W	348836	80031	CR251-4-5F39E	1		
R 44		RES, CF, 11, +-5%, 0.25W	442160	80031	CR251-4-5F11E	1		
R 47, 53		RES, CF, 330, +-5%, 0.25W	368720	80031	CR251-4-5F330E	2		
R 49, 52		RES, CF, 510, +-5%, 0.25W	441600	80031	CR251-4-5F510E	2		
R 55		RES, CF, 30K, +-5%, 0.25W	368753	80031	CR251-4-5F30K	1		
R 58		RES, VAR, CERM, 100K, +-10%, 0.5W	288308	89536	288308	1		
TP 1		TEST POINT	267508	00779	87022-1	2		
TP 2		TEST POINT	512889	02460	62395	1		
U 1	*	IC, ECL, TRIPLE LINE RECEIVER	369702	18324	N10116B	1		
U 2	*	IC, OP AMP, QUAD JFET INPUT, 14 PIN DIP	659748	89536	659748	1		1
U 3	*	IC, COMPARTOR, QUAD, 14 PIN DIP	387233	12040	LM339N	1		1
U 4	*	IC, COMPARTOR, 8 PIN DIP	352195	01295	SN72311P	1		1
U 5	*	IC, BFLR, FM IF AMPLIFIER-LIM & DETECT	772970	89536	772970	1		1
U 6	*	MIXER, DOUBLE BALANCED, 1 - 500 MHZ	733105	89536	733105	1		1
U 7	*	IC, OP AMP, DUAL, JFET INPUT, 8 PIN DIP	495192	12040	LF353RN	1		
XU 1		SOCKET, IC, 16 PIN	276535	91506	316-AG39D	1		
XU 2, 3, 5		SOCKET, IC, 14 PIN	276527	09922	DILB8P-108	3		
XU 4, 7		SOCKET, IC, 8 PIN	478016	91506	308-AG39D	2		
Z 1		RES, NET, SIP, 8 PIN, 7 RES, 510, +-2%	447482	89536	447482	1		1
Z 2		RES, NET, CERM, CUSTOM	501841	89536	501841	1		

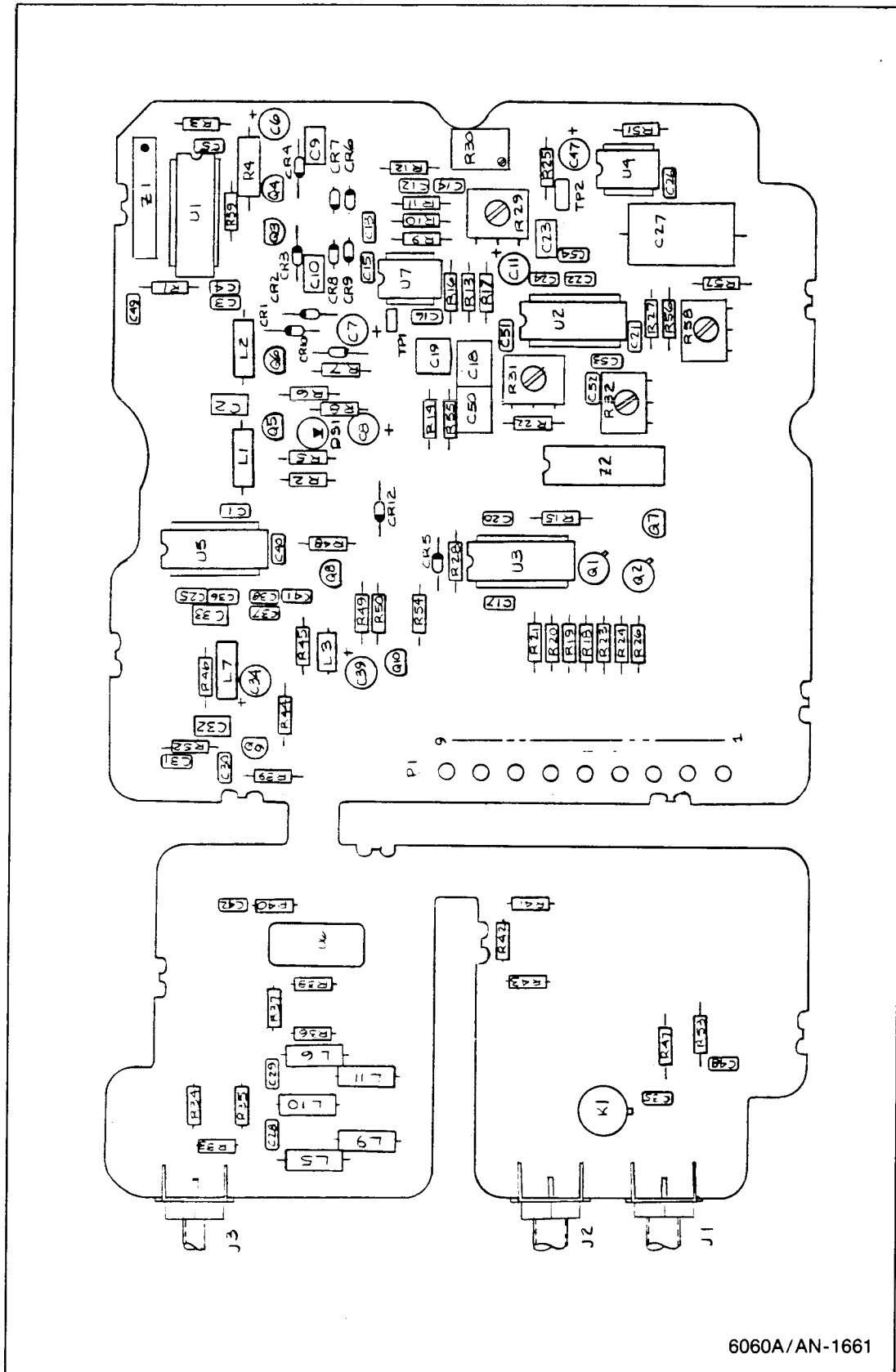

6060A/AN-1661

Figure 5-16. A4A1 Discriminator PCA

LIST OF REPLACEABLE PARTS

TABLE 5-17. A4A2 ANALOG/DIGITAL PCA
(SEE FIGURE 5-17.)

REFERENCE DESIGNATOR A->NUMERIC(S)--> S	DESCRIPTION	FLUKE STOCK --NO--	MFRS SPLY CODE-	MANUFACTURERS PART NUMBER --OR GENERIC TYPE--	TOT QTY	R S	N D T -E
C 1, 8	CAP. CER. 2000PF, +100-0%, 1000V. Z5U	105569	71590	DA140-139CB	2		
C 2- 5	CAP. POLYEST. 0.1UF, +-10%, 50V	696484	89536	696484	4		
C 6, 7	CAP. TA, 10UF, +-20%, 20V	330662	56289	196D106X0020KA1	2		
J 1	SOCKET, SIP, 16-POSITION	447102	89536	447102	2		
MP 1	SPACER	284372	89536	284372	3		
P 1	SOCKET, SINGLE, FWD, FOR .042-.049 PIN	544056	89536	544056	9		
R 1	RES. MF, 137, +-1%, 0.125W, 100PFM	235218	91637	CMF551370F	1	1	
U 1	* IC, BIPOLAR, 10 BIT A/D W/UPS INTERFACE	772939	89536	772939	1		
U 2	* IC, LSTTL, 3-8 LINE DCDR W/ENABLE	407585	01295	SN74LS138N	1	1	
U 3	* IC, LSTTL, OCTAL D F/F, +EDG TRG. W/CLEAR	454892	01295	SN74LS273N	1	1	
U 4	* IC, LSTTL, QUAD 2 INPUT NOR GATE	393041	01295	SN74LS02N	1	1	
U 5	* IC, LSTTL, HEX BUFFER W/NOR ENABLE	483800	01295	SN74LS367N	1	1	
XU 1	SOCKET, IC, 20 PIN	454421	09922	DILB20P-108	1		

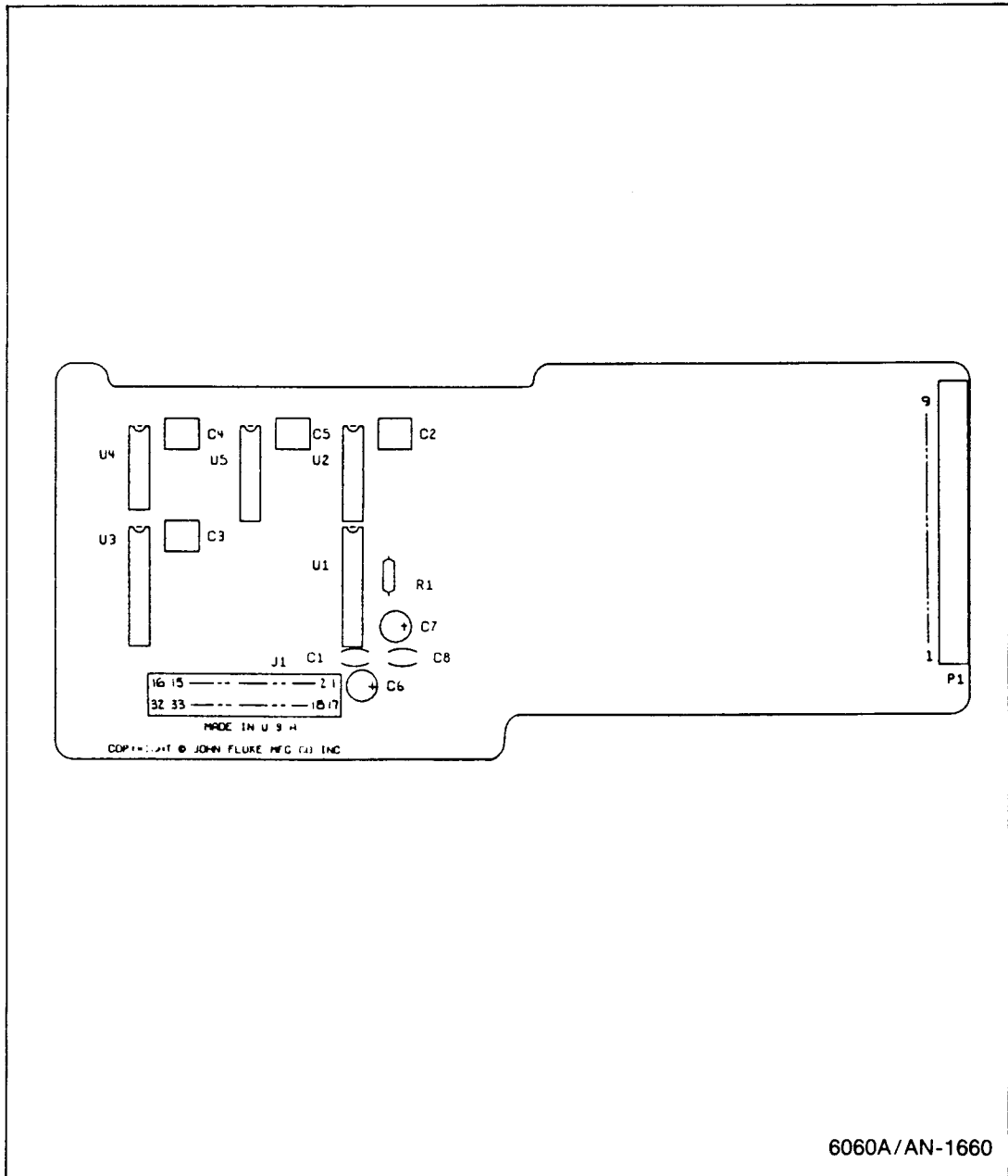

6060A/AN-1660

Figure 5-17. A4A2 Analog/Digital PCA

Section 6 Options

6-1. INTRODUCTION

The 6060A/AN does not have any options.

Section 7

General Information

7-1. This section of the manual contains generalized user information as well as supplemental information to the List of Replaceable Parts contained in Section 5.

List of Abbreviations and Symbols

A or amp	ampere	hf	high frequency	(+) or pos	positive
ac	alternating current	Hz	hertz	pot	potentiometer
af	audio frequency	IC	integrated circuit	p-p	peak-to-peak
a/d	analog-to-digital	if	intermediate frequency	ppm	parts per million
assy	assembly	in	inch(es)	PROM	programmable read-only memory
AWG	american wire gauge	intl	internal	psi	pound-force per square inch
B	bel	I/O	input/output	RAM	random-access memory
bcd	binary coded decimal	k	kilo (10 ³)	rf	radio frequency
°C	Celsius	kHz	kilohertz	rms	root mean square
cap	capacitor	kΩ	kilohm(s)	ROM	read-only memory
ccw	counterclockwise	kV	kilovolt(s)	s or sec	second (time)
cer	ceramic	lf	low frequency	scope	oscilloscope
cermet	ceramic to metal(seal)	LED	light-emitting diode	SH	shield
ckt	circuit	LSB	least significant bit	Si	silicon
cm	centimeter	LSD	least significant digit	serno	serial number
cmrr	common mode rejection ratio	M	mega (10 ⁶)	sr	shift register
comp	composition	m	milli (10 ⁻³)	Ta	tantalum
cont	continue	mA	milliamper(e)s	tb	terminal board
crt	cathode-ray tube	max	maximum	tc	temperature coefficient or temperature compensating
cw	clockwise	mf	metal film	tcxo	temperature compensated crystal oscillator
d/a	digital-to-analog	MHz	megahertz	tp	test point
dac	digital-to-analog converter	min	minimum	u or μ	micro (10 ⁻⁶)
dB	decibel	mm	millimeter	uhf	ultra high frequency
dc	direct current	ms	millisecond	us or μs	microsecond(s) (10 ⁻⁶)
dmm	digital multimeter	MSB	most significant bit	uut	unit under test
dvm	digital voltmeter	MSD	most significant digit	V	volt
elect	electrolytic	MTBF	mean time between failures	v	voltage
ext	external	MTTR	mean time to repair	var	variable
F	farad	mV	millivolt(s)	vco	voltage controlled oscillator
°F	Fahrenheit	mv	multivibrator	vhf	very high frequency
FET	Field-effect transistor	MΩ	megohm(s)	vlf	very low frequency
ff	flip-flop	n	nano (10 ⁻⁹)	W	watt(s)
freq	frequency	na	not applicable	ww	wire wound
FSN	federal stock number	NC	normally closed	xfrm	transformer
g	gram	(-) or neg	negative	xstr	transistor
G	giga (10 ⁹)	NO	normally open	xtal	crystal
gd	guard	ns	nanosecond	xtlo	crystal oscillator
Ge	germanium	opnl ampl	operational amplifier	Ω	ohm(s)
GHz	gigahertz	p	pico (10 ⁻¹²)	μ	micro (10 ⁻⁶)
gmV	guaranteed minimum value	para	paragraph		
gnd	ground	pcb	printed circuit board		
H	henry	pF	picofarad		
hd	heavy duty	pn	part number		

Federal Supply Codes for Manufacturers

00213 Nytronics Comp. Group Inc. Subsidiary of Nytronics Inc. Formerly Sage Electronics Rochester, New York	02660 Bunker Ramo Corp., Conn Div. Formerly Amphenol-Borg Electric Corp. Broadview, Illinois	04946 Standard Wire & Cable Los Angeles, California	06751 Components, Inc. Semcor Div. Phoenix, Arizona
00327 Welwyn International, Inc. Westlake, Ohio	02799 Aero Capacitors, Inc. Chatsworth, California	05082 Replaced by 94988	06860 Gould Automotive Div City of Industry, California
00656 Aerovox Corp. New Bedford, Massachusetts	03508 General Electric Co. Semiconductor Products Syracuse, New York	05236 Jonathan Mfg. Co. Fullerton, California	06961 Vernitron Corp., Piezo Electric Div. Formerly Clevite Corp., Piezo Electric Div. Bedford, Ohio
00686 Film Capacitors, Inc. Passaic, New Jersey	03614 Replaced by 71400	05245 Components Corp. now Corcom, Inc. Chicago, Illinois	06980 Eimac Div. Varian Associates San Carlos, California
00779 AMP Inc. Harrisburg, Pennsylvania	03651 Replaced by 44655	05277 Westinghouse Electric Corp. Semiconductor Div. Youngwood, Pennsylvania	07047 The Ross Milton Co South Hampton, Pennsylvania
01121 Allen-Bradley Co. Milwaukee, Wisconsin	03797 Eldema Div. Genisco Technology Corp. Compton, California	05278 Replaced by 43543	07115 Replaced by 14674
01281 TRW Electronic Comp. Semiconductor Operations Lawndale, California	03877 Transistron Electronic Corp. Wakefield, Massachusetts	05279 Southwest Machine & Plastic Co. Glendora, California	07138 Westinghouse Electric Corp., Electronic Tube Div. Horsehead, New York
01295 Texas Instruments, Inc. Semiconductor Group Dallas, Texas	03888 KDI Pyrofilm Corp. Whippany, New Jersey	05397 Union Carbide Corp. Materials Systems Div. New York, New York	07233 TRW Electronic Components Cinch Graphic City of Industry, California
01537 Motorola Communications & Electronics Inc. Franklin Park, Illinois	03911 Clairex Electronics Div. Clairex Corp. Mt. Vernon, New York	05571 Use 56289 Sprague Electric Co. Pacific Div. Los Angeles, California	07256 Silicon Transistor Corp. Div. of BBF Group Inc. Chelmsford, Massachusetts
01686 RCL Electronics Inc. Manchester, New Hampshire	03980 Muirhead Inc. Mountainside, New Jersey	05574 Viking Industries Chatsworth, California	07261 Aumet Corp. Culver City, California
01730 Replaced by 73586	04009 Arrow Hart Inc. Hartford, Connecticut	05704 Replaced by 16258	07263 Fairchild Semiconductor Div. of Fairchild Camera & Instrument Corp Mountain View, California
01884 Use 56289 Sprague Electric Co. Dearborn Electronic Div. Lockwood, Florida	04062 Replaced by 72136	05820 Wakefield Engineering Inc. Wakefield, Massachusetts	07344 Bircher Co., Inc. Rochester, New York
02114 Ferroxcube Corp. Saugerties, New York	04202 Replaced by 81312	06001 General Electric Co. Electronic Capacitor & Battery Products Dept. Columbia, South Carolina	07597 Burndy Corp. Tape/Cable Div. Rochester, New York
02131 General Instrument Corp. Harris ASW Div. Westwood, Maine	04217 Essex International Inc. Wire & Cable Div. Anaheim, California	06136 Replaced by 63743	07792 Lerma Engineering Corp. Northampton, Massachusetts
02395 Rason Mfg. Co. Brooklyn, New York	04221 Aemco, Div. of Midtex Inc. Mankato, Minnesota	06383 Panduit Corp. Tinley Park, Illinois	07910 Teledyne Semiconductor Formerly Continental Device Hawthorne, California
02533 Snelgrove, C.R. Co., Ltd Don Mills, Ontario, Canada M3B 1M2	04222 AVX Ceramics Div. AVX Corp. Myrtle Beach, Florida	06473 Bunker Ramo Corp. Amphenol SAMS Div. Chatsworth, California	07933 Use 49956 Raytheon Co. Semiconductor Div. HQ Mountain View, California
02606 Fenwal Labs Div. of Travenal Labs. Morton Grove, Illinois	04423 Telonic Industries Laguna Beach, California	06555 Beede Electrical Instrument Co. Penacook, New Hampshire	08225 Industro Transistor Corp Long Island City, New York
	04645 Replaced by 75376	06739 Electron Corp. Littleton, Colorado	
	04713 Motorola Inc. Semiconductor Products Phoenix, Arizona	06743 Clevite Corp. Cleveland, Ohio	

Federal Supply Codes for Manufacturers (cont)

08261 Spectra Strip Corp. Garden Grove, California	11726 Qualidyne Corp. Santa Clara, California	13606 Use 56289 Sprague Electric Co. Transistor Div. Concord, New Hampshire	16299 Corning Glass Electronic Components Div. Raleigh, North Carolina
08530 Reliance Mica Corp. Brooklyn, New York	12014 Chicago Rivet & Machine Co. Bellwood, Illinois	13839 Replaced by 23732	16332 Replaced by 28478
08806 General Electric Co. Miniature Lamp Products Dept Cleveland, Ohio	12040 National Semiconductor Corp. Danbury, Connecticut	14099 Semtech Corp. Newbury Park, California	16473 Cambridge Scientific Ind. Div. of Chemed Corporation Cambridge, Maryland
08863 Nyomatic Corp. Norrisville, Pennsylvania	12060 Diodes, Inc. Chatsworth, California	14140 Edison Electronic Div. Mc Gray-Edison Co. Manchester, New Hampshire	16742 Paramount Plastics Fabricators, Inc. Downey, California
08988 Use 53085 Skottie Electronics Inc. Archbald, Pennsylvania	12136 Philadelphia Handle Co. Camden, New Jersey	14193 Cal-R-Inc. formerly California Resistor, Corp. Santa Monica, California	16758 Delco Electronics Div. of General Motors Corp. Kokomo, Indiana
09214 G.E. Co. Semi-Conductor Products Dept. Power Semi-Conductor Products OPN Sec. Auburn, New York	12300 Potter-Brumfield Div. AMF Canada LTD. Guelph, Ontario, Canada	14298 American Components, Inc. an Insilco Co. Conshohocken, Pennsylvania	17001 Replaced by 71468
09353 C and K Components Watertown, Massachusetts	12323 Presin Co., Inc. Shelton, Connecticut	14655 Cornell-Dublier Electronics Division of Federal Pacific Electric Co. Govt. Control Dept. Newark, New Jersey	17069 Circuit Structures Lab. Burbank, California
09423 Scientific Components, Inc. Santa Barbara, California	12327 Freeway Corp. formerly Freeway Washer & Stamping Co. Cleveland, Ohio	14752 Electro Cube Inc. San Gabriel, California	17338 High Pressure Eng. Co., Inc. Oklahoma City, Oklahoma
09922 Burndy Corp. Norwalk, Connecticut	12443 The Budd Co. Polychem Products Plastic Products Div. Bridgeport, Pennsylvania	14869 Replaced by 96853	17545 Atlantic Semiconductors, Inc. Asbury Park, New Jersey
09969 Dale Electronics Inc. Yankton, S. Dakota	12615 U.S. Terminals Inc. Cincinnati, Ohio	14936 General Instrument Corp. Semi Conductor Products Group Hicksville, New York	17856 Siliconix, Inc. Santa Clara, California
10059 Barker Engineering Corp. Formerly Amerace, Amerace ESNA Corp. Kenilworth, New Jersey	12617 Hamlin Inc. Lake Mills, Wisconsin	15636 Elec-Trol Inc. Saugus, California	17870 Replaced by 14140
11236 CTS of Berne Berne, Indiana	12697 Clarostat Mfg. Co. Dover, New Hampshire	15801 Fenwal Electronics Inc. Div. of Kidde Walter and Co., Inc. Framingham, Massachusetts	18178 Vactec Inc. Maryland Heights, Missouri
11237 CTS Keene Inc. Paso Robles, California	12749 James Electronics Chicago, Illinois	15818 Teledyne Semiconductors, formerly Amelco Semiconductor Mountain View, California	18324 Signetics Corp. Sunnyvale, California
11358 CBS Electronic Div. Columbia Broadcasting System Newburyport, Minnesota	12856 Micrometals Sierra Madre, California	15849 Litton Systems Inc. Useco Div. formerly Useco Inc. Van Nuys, California	18612 Vishay Resistor Products Div. Vishay Intertechnology Inc. Malvern, Pennsylvania
11403 Best Products Co. Chicago, Illinois	12954 Dickson Electronics Corp. Scottsdale, Arizona	15898 International Business Machines Corp. Essex Junction, Vermont	18736 Voltronics Corp. Hanover, New Jersey
11503 Keystone Columbia Inc. Warren, Michigan	12969 Unitrode Corp. Watertown, Massachusetts	15909 Replaced by 14140	18927 GTE Sylvania Inc. Precision Material Group Parts Division Titusville, Pennsylvania
11532 Teledyne Relays Hawthorne, California	13103 Thermalloy Co., Inc. Dallas, Texas	16258 Space-Lok Inc. Burbank, California	19451 Perine Machinery & Supply Co. Seattle, Washington
11711 General Instrument Corp. Rectifier Division Hicksville, New York	13327 Solitron Devices Inc. Tappan, New York	16473 Cambridge Scientific Ind. Div. of Chemed Corporation Cambridge, Maryland	19701 Electro-Midland Corp. Mepco-Electra Inc Mineral Wells, Texas
	13511 Amphenol Cadre Div. Bunker-Ramo Corp. Los Gatos, California	20584 Enochs Mfg. Inc. Indianapolis, Indiana	

Federal Supply Codes for Manufacturers (cont)

20891 Self-Organizing Systems, Inc. Dallas, Texas	28480 Hewlett Packard Co. Corporate HQ Palo Alto, California	43543 Nytronics Inc. Transformer Co. Div. Geneva, New York	70903 Beiden Corp. Geneva, Illinois
21604 Bucheys Stamping Co. Columbus, Ohio	28520 Heyman Mfg. Co. Kenilworth, New Jersey	44655 Ohmite Mfg. Co. Skokie, Illinois	71002 Birnbach Radio Co., Inc. Freeport, New York
21845 Solitron Devices Inc. Transistor Division Riviera Beach, Florida	29083 Monsanto, Co., Inc. Santa Clara, California	49671 RCA Corp. New York, New York	71400 Bussmann Mfg. Div. of McGraw-Edison Co. Saint Louis, Missouri
22767 ITT Semiconductors Palo Alto, California	29604 Stackpole Components Co. Raleigh, North Carolina	49956 Raytheon Company Lexington, Massachusetts	71450 CTS Corp. Elkhart, Indiana
23050 Product Comp. Corp. Mount Vernon, New York	30148 AB Enterprise Inc. Ahoskie, North Carolina	50088 Mostek Corp. Carrollton, Texas	71468 ITT Cannon Electric Inc. Santa Ana, California
23732 Tracor Inc. Rockville, Maryland	30323 Illinois Tool Works, Inc. Chicago, Illinois	50579 Litronix Inc. Cupertino, California	71482 Clare, C.P. & Co. Chicago, Illinois
23880 Stanford Applied Engrng. Santa Clara, California	31091 Optimax Inc. Coimar, Pennsylvania	51605 Scientific Components Inc. Linden, New Jersey	71590 Centrelab Electronics Div. of Globe Union Inc. Milwaukee, Wisconsin
23936 Pamotor Div., Wm. J. Purdy Co. Burlingame, California	32539 Mura Corp. Great Neck, New York	53021 Sangamo Electric Co. Springfield, Illinois	71707 Coto Coil Co., Inc. Providence, Rhode Island
24248 Replaced by 94222	32767 Griffith Plastic Corp. Burlingame, California	54294 Cutler-Hammer Inc. formerly Shallcross, A Cutter-Hammer Co. Selma, North Carolina	71744 Chicago Miniature Lamp Works Chicago, Illinois
24355 Analog Devices Inc. Norwood, Massachusetts	32879 Advanced Mechanical Components Northridge, California	55026 Simpson Electric Co. Div. of Am. Gage and Mach. Co. Elgin, Illinois	71785 TRW Electronics Components Cinch Connector Operations Div. Elk Grove Village Chicago, Illinois
24655 General Radio Concord, Massachusetts	32897 Erie Technological Products, Inc. Frequency Control Div. Carlisle, Pennsylvania	56289 Sprague Electric Co. North Adams, Massachusetts	72005 Wilber B. Driver Co. Newark, New Jersey
24759 Lenox Fugle Electronics Inc. South Plainfield, New Jersey	32997 Bourns Inc. Trimpot Products Division Riverside, California	58474 Superior Electric Co. Bristol, Connecticut	72092 Replaced by 06980
25088 Siemen Corp. Islen, New Jersey	33173 General Electric Co. Products Dept. Owensboro, Kentucky	60399 Torin Corp. formerly Torrington Mfg. Co. Torrington, Connecticut	72136 Electro Motive Mfg. Co. Williamantic, Connecticut
25403 Amperex Electronic Corp. Semiconductor & Micro-Circuits Div. Slatersville, Rhode Island	34333 Silicon General Westminster, California	63743 Ward Leonard Electric Co., Inc. Mount Vernon, New York	72259 Nytronics Inc. Pelham Manor, New Jersey
27014 National Semiconductor Corp. Santa Clara, California	34335 Advanced Micro Devices Sunnyvale, California	64834 West Mfg. Co. San Francisco, California	72619 Dialight Div. Amperex Electronic Corp. Brooklyn, New York
27264 Molex Products Downers Grove, Illinois	34802 Electromotive Inc. Kenilworth, New Jersey	65092 Weston Instruments Inc. Newark, New Jersey	72653 G.C. Electronics Div. of Hydrometals, Inc. Brooklyn, New York
28213 Minnesota Mining & Mfg. Co. Consumer Products Div. St. Paul, Minnesota	37942 P.R. Mallory & Co., Inc. Indianapolis, Indiana	66150 Winslow Tele-Tronics Inc. Eaton Town, New Jersey	72665 Replaced by 90303
28425 Serv-Link formerly Bohannon Industries Fort Worth, Texas	42498 National Radio Melrose, Massachusetts	70485 Atlantic India Rubber Works Chicago, Illinois	72794 Dzus Fastener Co., Inc. West Islip, New York
28478 Deltrol Controls Div. Deltrol Corporation Milwaukee, Wisconsin		70563 Amperite Company Union City, New Jersey	72928 Gulton Ind. Inc. Gudeman Div. Chicago, Illinois

Federal Supply Codes for Manufacturers (cont)

72982 Erie Tech. Products Inc. Erie, Pennsylvania	75382 Kulka Electric Corp. Mount Vernon, New York	80583 Hammarlund Mfg. Co., Inc. Red Bank, New Jersey	83594 Burroughs Corp. Electronic Components Div. Plainfield, New Jersey
73138 Bechman Instrument Inc. Helipot Division Fullerton, California	75915 Littlefuse Inc. Des Plaines, Illinois	80640 Arnold Stevens, Inc. South Boston, Massachusetts	83740 Union Carbide Corp. Battery Products Div. formerly Consumer Products Div. New York, New York
73293 Hughes Aircraft Co. Electron Dynamics Div. Torrance, California	76854 Oak Industries Inc. Switch Div. Crystal Lake, Illinois	81073 Grayhill, Inc. La Grange, Illinois	84171 Arco Electronics Great Neck, New York
73445 Amperex Electronic Corp. Hicksville, New York	77342 AMF Inc. Potter & Brumfield Div. Princeton, Indiana	81312 Winchester Electronics Div. of Litton Industries Inc. Oakville, Connecticut	84411 TRW Electronic Components TRW Capacitors Ogallala, Nebraska
73559 Carling Electric Inc. West Hartford, Connecticut	77638 General Instrument Corp. Rectifier Division Brooklyn, New York	81483 Therm-O-Disc Inc. Mansfield, Ohio	84613 Fuse Indicator Corp. Rockville, Maryland
73586 Circle F Industries Trenton, New Jersey	77969 Rubbercraft Corp. of CA, LTD. Torrance, California	81483 International Rectifier Corp. Los Angeles, California	84682 Essex International Inc. Industrial Wire Div. Peabody, Massachusetts
73734 Federal Screw Products, Inc. Chicago, Illinois	78189 Shakeproof Div. of Illinois Tool Works Inc. Elgin, Illinois	81590 Korry Mfg. Co. Seattle, Washington	86577 Precision Metal Products of Malden Inc. Stoneham, Massachusetts
73743 Fischer Special Mfg. Co. Cincinnati, Ohio	78277 Sigma Instruments, Inc. South Braintree, Massachusetts	81741 Chicago Lock Co. Chicago, Illinois	86684 Radio Corp. of America Electronic Components Div. Harrison, New Jersey
73899 JFD Electronics Co. Components Corp. Brooklyn, New York	78488 Stackpole Carbon Co. Saint Marys, Pennsylvania	82305 Palmer Electronics Corp. South Gate, California	86928 Seastrom Mfg. Co., Inc. Glendale, California
73949 Guardian Electric Mfg. Co. Chicago, Illinois	78553 Eaton Corp. Engineered Fastener Div. Tinnerman Plant Cleveland, Ohio	82389 Switchcraft Inc. Chicago, Illinois	87034 Illuminated Products Inc. Subsidiary of Oak Industries Inc. Anaheim, California
74199 Quan Nichols Co. Chicago, Illinois	79136 Waldes Kohinoor Inc. Long Island City, New York	82415 North American Phillips Controls Corp. Frederick, Maryland	88219 Gould Inc. Industrial Div. Trenton, New Jersey
74217 Radio Switch Corp. Marlboro, New Jersey	79497 Western Rubber Company Goshen, Indiana	82472 Roanwell Corp. New York, New York	88245 Litton Systems Inc. Useco Div. Van Nuys, California
74276 Signalite Div. General Instrument Corp. Neptune, New Jersey	79963 Zierick Mfg. Corp. Mt. Kisko, New York	82877 Rotron Inc. Woodstock, New York	88419 Cornell-Dubilier Electronic Div. Federal Pacific Co. Fuquay-Varian, North Carolina
74306 Piezo Crystal Co. Carlisle, Pennsylvania	80031 Electro-Midland Corp. Mepco Div. A North American Phillips Co. Norristown, New Jersey	82879 ITT Royal Electric Div. Pawtucket, Rhode Island	88486 Plastic Wire & Cable Jewitt City, Connecticut
74542 Hoyt Elect. Instr. Works Penacook, New Hampshire	80145 LFE Corp., Process Control Div. formerly API Instrument Co. Chesterland, Ohio	83003 Varo Inc. Garland, Texas	88690 Replaced by 04217
74970 Johnson E.F., Co. Waseca, Minnesota	80183 Use 56289 Sprague Products North Adams, Massachusetts	83058 The Carr Co., United Can Div. of TRW Cambridge, Massachusetts	89536 John Fluke Mfg. Co., Inc. Seattle, Washington
75042 TRW Electronics Components IRC Fixed Resistors Philadelphia, Pennsylvania	80294 Bourns Inc., Instrument Div. Riverside, California	83298 Bendix Corp. Electric Power Div. Eatontown, New Jersey	89730 G.E. Co., Newark Lamp Works Newark, New Jersey
75376 Kurz-Kasch Inc. Dayton, Ohio		83330 Herman H. Smith, Inc. Brooklyn, New York	
75378 CTS Knights Inc. Sandwich, Illinois		83478 Rubbercraft Corp. of America, Inc. West Haven, Connecticut	

Federal Supply Codes for Manufacturers (cont)

90201
Mallory Capacitor Co.
Div. of P.R. Mallory Co., Inc.
Indianapolis, Indiana

90211
Use 56365
Square D Co.
Chicago, Illinois

90215
Best Stamp & Mfg. Co.
Kansas City, Missouri

90303
Mallory Battery Co.
Div. of Mallory Co., Inc.
Tarrytown, New York

91094
Essex International Inc.
Suglex/IWP Div.
Newmarket, New Hampshire

91293
Johanson Mfg. Co.
Boonton, New Jersey

91407
Replaced by 58474

91502
Associated Machine
Santa Clara, California

91506
Augat Inc.
Attleboro, Massachusetts

91637
Dale Electronics Inc.
Columbus, Nebraska

91662
Elco Corp.
Willow Grove, Pennsylvania

91737
Use 71468
Gremar Mfg. Co., Inc.
ITT Cannon/Gremar
Santa Ana, California

91802
Industrial Devices, Inc.
Edgewater, New Jersey

91833
Keystone Electronics Corp.
New York, New York

91836
King's Electronics Co., Inc.
Tuckahoe, New York

91929
Honeywell Inc.
Micro Switch Div.
Freeport, Illinois

91934
Miller Electric Co., Inc.
Div. of Aunet
Woonsocket, Rhode Island

92194
Alpha Wire Corp.
Elizabeth, New Jersey

93332
Sylvania Electric Products
Semiconductor Products Div.
Woburn, Massachusetts

94145
Replaced by 49956

94154
Use 94988
Wagner Electric Corp.
Tung-Sol Div.
Newark, New Jersey

94222
Southco Inc. formerly
South Chester Corp.
Lester, Pennsylvania

95146
Alco Electronic Products Inc.
Lawrence, Massachusetts

95263
Leecraft Mfg. Co.
Long Island City, New York

95264
Replaced by 98278

95275
Vitramon Inc.
Bridgeport, Connecticut

95303
RCA Corp.
Receiving Tube Div.
Cincinnati, Ohio

95348
Gordo's Corp.
Bloomfield, New Jersey

95354
Methode Mfg. Corp.
Rolling Meadows, Illinois

95712
Bendix Corp.
Electrical Components Div.
Microwave Devices Plant
Franklin, Indiana

95987
Weckesser Co. Inc.
Chicago, Illinois

96733
San Fernando Electric Mfg. Co.
San Fernando, California

96853
Gulton Industries Inc.
Measurement and Controls Div.
formerly Rustrak Instruments Co.
Manchester, New Hampshire

96881
Thomson Industries, Inc.
Manhasset, New York

97540
Master Mobile Mounts, Div. of
Whitehall Electronics Corp.
Ft. Meyers, Florida

97913
Industrial Electronic
Hardware Corp.
New York, New York

97945
Penwalt Corp.
SS White Industrial Products Div.
Piscataway, New Jersey

97966
Replaced by 11358

98094
Replaced by 49956

98159
Rubber-Teck, Inc.
Gardena, California

98278
Malco A Microdot Co., Inc.
Connector & Cable Div.
Pasadena, California

98291
Sealectro Corp.
Mamaroneck, New York

98388
Royal Industries
Products Div.
San Diego, California

98743
Replaced by 12749

98925
Replaced by 14433

99120
Plastic Capacitors, Inc.
Chicago, Illinois

99217
Bell Industries Elect.
Comp. Div.
formerly Southern Elect. Div.
Burbank, California

99392
STM
Oakland, California

99515
ITT Jennings Monrovia Plant
Div. of ITT Jennings formerly
Marshall Industries Capacitor Div.
Monrovia, California

99779
Use 29587
Bunker-Ramo Corp.
Barnes Div.
Landsdowne, Pennsylvania

99800
American Precision Industries Inc.
Delevan Division
East Aurora, New York

99942
Centrelab Semiconductor
Centrelab Electronics Div. of
Globe-Union Inc.
El Monte, California

Toyo Electronics
(R-Ohm Corp.)
Irvine, California

National Connector
Minneapolis, Minnesota

U.S. SALES AREAS for all Fluke products

AL, Huntsville

John Fluke Mfg. Co., Inc.
4920 Corporate Drive
Suite J
Huntsville, AL 35805-6202
(205) 830-9671

AZ, Tempe

John Fluke Mfg. Co., Inc.
2211 S. 48th Street
Suite B
Tempe, AZ 85282
(602) 438-8314

CA, Burbank

John Fluke Mfg. Co., Inc.
2020 N. Lincoln Street
Burbank, CA 91504
(213) 849-7181

Irvine

P.O. Box 19676
Irvine, CA 92713-9676
16969 Von Karman
Suite 100
Irvine, CA 92714
(714) 863-9031

San Diego

John Fluke Mfg. Co., Inc.
4540 Kearny Villa Road
Suite 115
San Diego, CA 92123
(619) 292-7656

Santa Clara

John Fluke Mfg. Co., Inc.
2300 Walsh Ave., Bldg. K
Santa Clara, CA 95051
(408) 727-0513

CO, Denver

John Fluke Mfg. Co., Inc.
14180 E. Evans Ave.
Aurora, CO 80014
(303) 695-1000

CT, Hartford

John Fluke Mfg. Co., Inc.
Glen Lochen East
41-C New London Turnpike
Glastonbury, CT 06033
(203) 659-3541

FL, Clearwater

(813) 799-0087

Orlando

John Fluke Mfg. Co., Inc.
940 N. Fern Creek Ave.
Orlando, FL 32803
(305) 896-4881

Tampa

(813) 251-9211

GA, Atlanta

John Fluke Mfg. Co., Inc.
2600 Delk Road
Suite 150
Marietta, GA 30067
(404) 953-4747

IL, Chicago

John Fluke Mfg. Co., Inc.
1150 W. Euclid Avenue
Palatine, IL 60067
(312) 398-0850
(312) 392-9510

IN, Indianapolis

John Fluke Mfg. Co., Inc.
8777 Purdue Road
Suite 101
Indianapolis, IN 46268
(317) 875-7870

MA, Billerica

John Fluke Mfg. Co., Inc.
900 Middlesex Turnpike
Building 8
Billerica, MA 01821
(617) 663-2400

MD, Baltimore

(301) 792-7060

Rockville

John Fluke Mfg. Co., Inc.
5640 Fishers Lane
Rockville, MD 20852
(301) 770-1570

MI, Detroit

John Fluke Mfg. Co., Inc.
33031 Schoolcraft
Livonia, MI 48150
(313) 522-9140

MN, Bloomington

John Fluke Mfg. Co., Inc.
1801 E. 79th St., Suite 9
Bloomington, MN 55420
(612) 854-5526

MO, St. Louis

John Fluke Mfg. Co., Inc.
2029 Woodland Parkway
Suite 105
St. Louis, MO 63146
(314) 993-3805

NC, Greensboro

John Fluke Mfg. Co., Inc.
1310 Beaman Place
Greensboro, NC 27408
(919) 273-1918

NJ, Paramus

John Fluke Mfg. Co., Inc.
P.O. Box 930
Paramus, NJ 07653-0930
West 75 Century Road
Paramus, NJ 07652
(201) 262-9550

NY, Rochester

John Fluke Mfg. Co., Inc.
4515 Culver Road
Rochester, NY 14622
(716) 323-1400

OH, Cleveland

John Fluke Mfg. Co., Inc.
7830 Freeway Circle
Middleburg Heights, OH 44130
(216) 234-4540

Columbus

(614) 889-5715

Dayton

John Fluke Mfg. Co., Inc.
4756 Fishburg Rd.
Dayton, OH 45424
(513) 233-2238

PA, Malvern

John Fluke Mfg. Co., Inc.
200 Lindenwood Drive
Malvern, PA 19355
(215) 647-9550

TX, Dallas

John Fluke Mfg. Co., Inc.
1801 Royal Lane
Suite 307
Dallas, TX 75229
(214) 869-0311

San Antonio

John Fluke Mfg. Co., Inc.
10417 Gulfdale
San Antonio, TX 78216
(512) 340-1011

WA, Seattle

John Fluke Mfg. Co., Inc.
5020 148th Ave. N.E.
Suite 110
Redmond, WA 98052
(206) 881-6966

Service Center Areas

CA, Burbank (213) 849-7181
CA, Santa Clara (408) 727-0513
CO, Denver (303) 695-1000
FL, Orlando (305) 896-4881
IL, Chicago (312) 392-9510
MA, Billerica (617) 663-2400
MD, Rockville (301) 770-1570
NJ, Paramus (201) 262-9550
TX, Dallas (214) 869-0311
WA, Everett (206) 356-5560

For more information on Fluke products or Sales Offices you may dial (800) 426-0361 toll-free in most of the U.S.A.
From Alaska, Hawaii, or Washington phone (206) 356-5400. From Canada and other countries phone (206) 356-5500.



John Fluke Mfg. Co., Inc., P.O. Box C9090, Everett, WA 98206
Fluke (Holland) B.V., P.O. Box 2269, 5600 CG, Eindhoven, The Netherlands. Phone (040) 458045, TLX 51846
Litho in U.S.A. 11/85

INTERNATIONAL SALES OFFICES

Argentina •

Coasin S.A.
Virrey del Pino 4071 DEP E-1
1430 CAP FED
Buenos Aires, Argentina
Tel: (1) 552-5248, TLX: (390) 22284

Australia •

Elmeasco Instruments Pty. Ltd.
P.O. Box 30
Concord, N.S.W. 2137
Australia
Tel: (2) 736-2888, TLX: (790) AA25887

Elmeasco Instruments Pty. Ltd.
P.O. Box 623
12 Maroondah Highway
Ringwood, Victoria 3134
Australia
Tel: (3) 879-2322, TLX: (790) AA36206

Elmeasco Instruments Pty. Ltd.
Professional Suites Bldg.
G.P.O. Box 2360
Brisbane 4001, Australia
Tel: (7) 369-8688, TLX: (790) AA44062

Elmeasco Instruments Pty. Ltd.
G.P.O. Box 1240
Adelaide, South Australia 5001
Tel: (8) 271-1839

Elmeasco Instruments Pty. Ltd.
P.O. Box 95
Gosnells, West Australia 6110
Australia
Tel: (9) 398-3362

Austria ■

Walter Rekirsch Elektronische
Geräte GmbH & Co.
Vertrieb KG
Obachgasse 28
1220 Vienna, Austria
Tel: (222) 235555, TLX: (847) 134759

Bahrain ■

Basma
P.O. Box 5701
Manama, Bahrain
Tel: 251-364; TLX: (955) 9003

Bangladesh •

Motherland Corporation
24 Hathkolia Road, Tikatuli
Dacca-3, Bangladesh
Tel: 257249 or 255776
TLX: (950) 642022

Belgium ■

Fluke (Belgium) S.A./N.V.
6 Rue de Geneve
1140 Brussels
Belgium
Tel: (2) 2164090, TLX: (846) 26312

Bolivia •

Coasin Bolivia S.R.L.
Casilla 7295
La Paz, Bolivia
Tel: (2) 40962, TLX: (336) 5255

Brazil •

Hi-Tek Eletronica Ltda.
Al. Amazonas 422,
Alphaville, Barueri,
CEP 06400, Sao Paulo, Brazil
Tel: (11) 421-5477, TLX: (391) 01135589

Brunei •

Rank O'Connor's Berhad
No. 8 Bk D
Sufri Shophouse Complex
Mile 1 Jalan Tutong
Bandar Seri Begawan
Negara Brunei Darussalam
Tel: (2) 23109 or 23557
TLX: (799) 2265 RANKOC

Canada •

Allan Crawford Assoc., Ltd.
5835 Coopers Avenue
Mississauga, Ontario
L4Z 1Y2 Canada
Tel: (416) 890-2010, TLX: 0696 1235

Allan Crawford Assoc., Ltd.
7018 Cote de Liesse
St. Laurent, Quebec
H4T 1E7 Canada
Tel: (514) 731-8564
TLX: 05824944

Allan Crawford Assoc., Ltd.
2625 Queensview Drive
Ottawa, Ontario
K2B 8K2 Canada
Tel: (613) 596-9300, TLX: 0533600

Allan Crawford Assoc., Ltd.
Suite No. 106
4180 Loughheed Hwy.
Burnaby, British Columbia
V5C 6A7 Canada
Tel: (604) 294-1326, TLX: 0454247

Allan Crawford Assoc., Ltd.
1935 30th Avenue, N.E.
Calgary, Alberta
T2E 6Z5 Canada
Tel: (403) 230-1341, TLX: 03821186

Allan Crawford Assoc., Ltd.
800 Windmill Road
Suite 205
Dartmouth, N.S.
B3B 1L1 Canada
Tel: (902) 463-8640

Chile •

Intronica Chile, Ltda.
Manuel Montt 024-Of. D
Casilla 16228
Santiago 9, Chile
Tel: (2) 44940, TLX: (332) 240301

China, Peoples Republic of •

Fluke International Corp.
P.O. Box C9090 M/S 206A
Everett, WA 98206 U.S.A.
Tel: (206) 356-5511
TLX: 185103 FLUKE UT

Colombia •

Sistemas E Instrumentacion, Ltda.
Carrera 13, No. 37-43, Of. 401
Ap. Aereo 29583
Bogota DE, Colombia
Tel: 232-4532, TLX: (396) 45787

Cyprus ■

Chris Radiovision, Ltd.
P.O. Box 1989
Nicosia, Cyprus
Tel: (21) 66121, TLX: (826) 2395

Cyprus, Northern

Ucok Buroteknik
2C & 2D Muftu Ziyai Street
Lefkosa, Northern Cyprus
Mersin 10, Turkey
Tel: (741) 357-20-71777
TLX: (821) 57267

Czechoslovakia ■

Amtest Associates Ltd.
Clarence House
31 Clarence Street
Staines, Middlesex TW18 4SY
England
Tel: (784) 63555, TLX: (851) 928855

Denmark ■

Tage Olsen A/S
Ballerup Byvej 222
2750 Ballerup
Denmark
Tel: (2) 658111, TLX: (855) 35293

Ecuador •

Proteco Coasin Cia., Ltda.
P.O. Box 228-A
Ave. 12 de Octubre 2285
y Orellana
Quito, Ecuador
Tel: (2) 529684, TLX: (393) 2865

Proteco Coasin Cia., Ltda.
P.O. Box 9733
Ave. Principal No. 204
y Calle Segunda
Urbanizacion Miraflores
Guayaquil, Ecuador
Tel: (4) 387519

Egypt and Sudan ■

Electronic Engineering Liaison Office
P.O. Box 2891 Horreya
Heliopolis, Cairo
Egypt
Tel: (2) 695705, TLX: (927) 22782

England ■

Fluke GB, Ltd.
Colonial Way
Watford, Herts,
WD2 4TT England
Tel: (923) 40511, TLX: (851) 934583

Fiji •

Awa Fiji
47 Forster Road
Walu Bay
Suva, Fiji
Tel: 312079, TLX: (792) FJ2347

Finland ■

Instrumentarium Elektroniiiki oy
P.O. Box 64
02631 Espoo 63
Finland
Tel: (0) 5281, TLX: (857) 124426

France ■

M.B. Electronique S.A.
606, Rue Fournay
P.O. Box 31
78530 BUC, France
Tel: (3) 956-8131, TLX: (842) 695414

German Democratic Republic ■

Amtest Associates Ltd.
Clarence House, 31 Clarence St.
Staines, Middlesex TW18 4SY
United Kingdom
Tel: (784) 63555, TLX: (851) 928855

Germany, West ■

Fluke (Deutschland) GmbH
Oskar-Messter-Strasse 18
8045 Ismaning/Munich
West Germany
Tel: (89) 96050, TLX: (841) 0522472
Rapifax: 49-89-9605166

Fluke (Deutschland) GmbH
Viertriebsburo - Dusseldorf
Meineckestrasse 53, D-4000 Dusseldorf-30
West Germany
Tel: (211) 450831, TLX: (841) 17-2114233

Fluke (Deutschland) GmbH
Vertriebsburo - Hamburg
Habichthorst 42
D-2000 Hamburg 61
West Germany
Tel: (40) 5519031, TLX: (841) 02174556

Greece ■

Hellenic Scientific Representations Ltd.
11, Vrassida Street
Athens 612, Greece
Tel: (1) 711140, TLX: (863) 219330

Hong Kong •

Schmidt & Co (H.K.), Ltd
18th Floor, Great Eagle Centre
23 Harbour Road
Wanchai, Hong Kong
Tel: (5) 8330-222
TLX: (780) 74766 or (780) 76762

Hungary ■

Amtest Associates Ltd.
Clarence House, 31 Clarence St.
Staines, Middlesex TW18 4SY
United Kingdom
Tel: (784) 63555, TLX: (851) 928855

India •

Hinditron Services Pvt. Ltd.
69/A.L. Jagmohandas Marg
Bombay 400 006, India
Tel: (22) 8121316, 8125344, TLX: (953) 112326

Hinditron Services Pvt. Ltd.
8th Main Road
33/44A Raj Mahal Vilas Extension
Bangalore 560 080, India
Tel: (910) 33139, 367289; TLX: (953) 845741

Hinditron Services Pvt. Ltd.
5th Floor, "Castle House"
5/1A, Hungerford St.
Calcutta 700 017, India
Tel: 33-434628, TLX: 21-4153

Hinditron Services Pvt. Ltd.
204-5-6 Hemkunt Tower
98 Nehru Place
New Delhi, 110019, India
Tel: (910) 640380, TLX: (953) 3161458

Hinditron Services Pvt. Ltd.
1-1-58/1 to 1-1-58/11
Sarojini Devi Road
Secunderabad 500 003, India
Tel: (842) 821117, TLX: (953) 1556973

Indonesia •

P.T. Dwi Tunggal Jaya Sakti
P.O. Box 4435
Wisma Harapan Bldg. 14th
Jl. Jend. Sudirman Kav. 34
Jakarta Pusat, Indonesia
Tel: (21) 584685, TLX: (796) 47308

Ireland ■

Euro Instruments & Electronics Ltd.
Euro House
Swords Road, Santry
Dublin 9, Ireland
Tel: (1) 425666, TLX: (851) 31821

Israel ■

R.D.T. Electronics Engineering Ltd.
P.O. Box 43137
Tel Aviv 61430
Israel
Tel: (3) 483211, TLX: (922) 32143

Italy ■

Sistrel S.p.A.
Via Pelizza da Volpedo 59
20092 Cinisello Balsamo
Milan, Italy
Tel: (2) 6181893, TLX: (843) 334643

Sistrel S.p.A.
Via Giuseppe Armellini No. 39
00143 Rome, Italy
Tel: (6) 591-5551, TLX: (843) 680356

Sistrel S.p.A.
Via Cinta
Parco S. Paolo 35
80126 Naples, Italy
Tel: (81) 7679700

Japan •

John Fluke Mfg. Co., Inc.
Japan Branch
Sumitomo Higashi Shinbashi Bldg.
1-1-11 Hamamatsucho
Minato-ku, Tokyo 105, Japan
Tel: (3) 434-0181, TLX: (781) 2424331
FAX: 81-3-434-0170

John Fluke Mfg. Co., Inc.
Japan Branch
Katsushige Building
2-45 Kohraibashi
Higashi-ku, Osaka 541
Japan
Tel: (6) 229-0871



John Fluke Mfg. Co., Inc. / PO Box C9090 / Everett, WA 98206 / (206) 356 5400

Litho in U.S.A. 11/85

Korea, Republic of

Myoung Corporation
Rm #1501, Sinsong Bldg
25-4 Yeouido-Dong, Young Deung Po-ku
Seoul 150, Korea
Tel: (2) 784-9942, TLX: K24283

Kuwait

Al Bahar International Group
P.O. Box 26672 Safat
Kuwait, Arabian Gulf
Tel: 848601, 847598; TLX: (959) 44822

Lebanon and Jordan

Mabek (Electronics Division)
P.O. Box 13-5657
Beirut, Lebanon
Tel: 812523, TLX: (923) 22889

Malaysia

Mecomb Malaysia SND BHD
Lot 20, Jalan 225
P.O. Box 24
Petaling Jaya, Malaysia
Tel: (3) 743422, TLX: (784) MA37764

Malta

Fabian Enterprises
20, Msida Road
Gzira, Malta
Tel: 513283/40216, TLX: (838) 1837

Mexico

Industrial, S.A. (Mexel)
Diagonal No. 27
Entre Calle de Eugenia Y Ave
Colonia del Valle
C.P. 03100, Mexico
Tel: (5) 660-4323, TLX: (383) 1771038

Morocco

Oussama S.A.
Angle Boulevard Emile Zola et
Rue Rethel
P.O. Box 2007 Casa
Casablanca
Morocco
Tel: 24-13-38, TLX: 22730 M

Nepal

Associated Enterprises
GPO Box 790, Pyaphal Tole
Kathmandu, Nepal
Tel: 13868

Netherlands

Fluke (Holland) B.V.
P.O. Box 2269
5600 CG Eindhoven
Netherlands
Tel: (40) 458045, TLX: (844) 51846
Fluke (Nederland) B.V.
Gasthuisring 14
P.O. Box 115
5000 AC Tilburg
The Netherlands
Tel: (13) 352455, TLX: (844) 52683

New Zealand

Northrop Instruments & Systems, Ltd.
Information Technology Group
459 Khyber Pass Road
Private Bag, Newmarket
Auckland 1, New Zealand
Tel: (9) 501-801; TLX: (791) 21570

Northrop Instruments & Systems Ltd.
Information Technology Group
First Floor, Northrop Bldg.
189-191 Willis Street
P.O. Box 2406
Wellington, New Zealand
Tel: (4) 856-658, TLX: (791) 3380

Northrop Instruments & Systems Ltd.
Information Technology Group
110 Mandeville Street
P.O. Box 8388
Christchurch, New Zealand
Tel: (3) 488-874, TLX: (791) 4801

Norway

Morgenstjerne & Co A/S
Konghellegate 3
P.O. Box 6688, Rodelokka
Oslo 5, Norway
Tel: (2) 356110, TLX: (856) 71719

Oman

OHI Telecommunications
P.O. Box 889
Muscat
Sultanate of Oman
Tel: 603606, TLX: (926) 5052

Pakistan

International Operations (PAK), Ltd.
505 Muhammadi House
I.I. Chundrigar Road
P.O. Box 5323, Karachi, Pakistan
Tel: (21) 221127, TLX: (952) 24494

Peru

Importaciones y Representaciones
Electronicas S.A.
Avda. Franklin D. Roosevelt 105
Lima 1, Peru
Tel: (14) 28-8650, TLX: (394) 25663

Philippines, Republic of

Spark Radio & Electronics, Inc.
452 Shaw Boulevard
Mandaluyong, Metro Manila
Republic of Philippines
Tel: (2) 775192, TLX: (722 or 732) 27901

Poland

Amtest Associates Ltd.
Clarence House, 31 Clarence St.
Staines, Middlesex TW18 4SY
England
Tel: (784) 63555, TLX: (851) 928855

Portugal

Decada Espectral
Equipamentos de Electronica
Av. Bombeiros Voluntarios
Lote 102B, Miraflores/Alges
1495 Lisbon, Portugal
Tel: (1) 2103420, TLX: (832) 15515

Romania

Amtest Associates Ltd.
Clarence House, 31 Clarence St.
Staines, Middlesex TW18 4SY
England
Tel: (784) 63555, TLX: (851) 928855

Saudi Arabia

Electronic Equipment Marketing Co.
P.O. Box 3750
Riyadh, Saudi Arabia
Tel: (1) 477-1650, TLX: 201120

Singapore, Republic of

Rank O'Connor's (PTE) Ltd.
O'Connor House
98 Pasir Panjang Road
Singapore 0511
Republic of Singapore
Tel: 4737944, TLX: (786) RS21023

South Africa

Fluke S.A. (Pty) Ltd.
Wynberg Park
777 Andries Street
Wynberg, South Africa
Tel: (11) 786-3170, TLX: (960) 424328

Spain

ESSA
Equipos y Sistemas S.A.
C/Apolonio Morales, 13-B
Madrid 16, Spain
Tel: (1) 458-0150, TLX: (831) 42856

Sri Lanka

Computerlink Data Systems, Ltd.
294 Union Place
Colombo 2, Sri Lanka
Tel: (1) 28641/2, TLX: (954) 21321

Sweden

Telesinstrument AB
Maltesholmsvagen 138
P.O. Box 4490
162 04 Vällingby 4
Sweden
Tel: (8) 380370, TLX: (854) 15770

Switzerland

Traco Electronic AG
Jenatschstrasse 1
8002 Zurich
Switzerland
Tel: (1) 201-0711, TLX: (845) 815570

Syria

Mabek (Electronics Division)
P.O. Box 4238
Damascus, Syria

Taiwan

Schmidt Electronics Corp.
5th Fl, Cathay Min Sheng
Commercial Building,
344 Min Sheng East Road
Taipei 104, Taiwan R.O.C.
Tel: (2) 501-3468, TLX: (785) 11111

Thailand

Measuretronix Ltd.
2102/63 Ramkhamhaeng Rd.
Bangkok 10240
Thailand
Tel: (2) 378-2516, TLX: (788) 82796

Tunisia

Selep S.A.R.L.
6, Rue de Sparte
Tunis - 1000 RP
Tunisia
Tel: (1) 248093, TLX: (934) 13030

Turkey

Erkman Elektronik Aletler
Ticaret Anonim Sirketi
Necatibey Cad 92/3
Karakoy, Istanbul, Turkey
Tel: (1) 4415461, TLX: (821) 24395

United Arab Emirates

Al-Sanani Cen. Trad. Est.
P.O. Box 7187
Abu-Dhabi, U.A.E.
Tel: (2) 821370 or 821371
TLX: (958) 23966
Haris Al-Afag, Ltd.
P.O. Box 545
Sharjah, U.A.E.
Tel: (6) 359120, TLX: (958) 68540

Uruguay

Coasin Uruguayaya S.A.
Libertad 2529
Casilla de Correo 1400
Montevideo, Uruguay
Tel: (2) 789015, TLX: (398) UY23010

USSR

Amtest Associates Ltd.
Clarence House, 31 Clarence St.
Staines, Middlesex TW18 4SY
England
Tel: (784) 63555, TLX: (851) 928855

Venezuela

Coasin C.A.
Calle 9 Con Calle 4, Edif Edinurbi
Apartado de Correos NR-70.136
Los Ruices
Caracas 1070-A, Venezuela
Tel: (2) 239-0967, TLX: (395) 21027

Yugoslavia

Amtest Associates Ltd.
Clarence House, 31, Clarence St.
Staines, Middlesex TW18 4SY
England
Tel: (784) 63555, TLX: (851) 928855

Supplied and Supported by —

Fluke (Holland) B.V.
P.O. Box 2269
5600 CG Eindhoven
Netherlands
Tel: (040) 45805, TLX: 51846
FAX: 31-40-457515

Supplied and Supported by —

Fluke International Corporation
P.O. Box C9090
Everett, WA 98206 U.S.A.
Tel: (206) 356-5500
TLX: 185103 FLUKE UT
FAX: 206-356-5116

The following countries are
represented by:
Fluke (Holland) B.V.
P.O. Box 2269
5600 CG Eindhoven
Netherlands
Tel: (040) 45805, TLX: 51846
FAX: 31-40-457515

Abu Dhabi	Mauritania
Afghanistan	Menorca
Albania	Mongolia
Algeria	Niger
Angola	Nigeria
Benin	Qatar
Bornholm	Rodhos
Botswana	Russia
Chad	Sardinia
Corsica	Saudia Arabia
Czechoslovakia	Scotland
Dubai	Senegal
Ethiopia	Sierra Leone
Guinea	Somalia
Ibiza	Togo
Iceland	Upper Volta
Iraq	Wales
Kuwait	Wstn Sahara
Liberia	Yemen
Libya	Zaire
Luxembourg	Zambia
Maderia	Zimbabwe
Mallorca	

TECHNICAL SERVICE CENTERS

U.S.A.

CA, Burbank

John Fluke Mfg. Co., Inc.
(213) 849-7181

CA, Santa Clara

John Fluke Mfg. Co., Inc.
(408) 727-0513

CO, Denver

John Fluke Mfg. Co., Inc.
(303) 695-1000

FL, Orlando

John Fluke Mfg. Co., Inc.
(305) 896-4881

IL, Palatine

John Fluke Mfg. Co., Inc.
(312) 398-5800
(312) 392-9510

MD, Rockville

John Fluke Mfg. Co., Inc.
(301) 770-1576

NJ, Paramus

John Fluke Mfg. Co., Inc.
(201) 262-9550

TX, Dallas

John Fluke Mfg. Co., Inc.
(214) 869-0311

WA, Everett

John Fluke Mfg. Co., Inc.
(206) 356-5560

Other Countries

Argentina, Buenos Aires

Coasin S.A.
Tel: 552-5248
TLX: (390) 22284

Australia, Brisbane

Elmeasco Instruments Pty. Ltd.
Tel: 369-8688
TLX: (790) AA44062

Australia, Concord

Elmeasco Instruments Pty. Ltd.
Tel: 736-2888
TLX: (790) AA25887

Australia, Ringwood

Elmeasco Instruments Pty. Ltd.
Tel: 879-2322
TLX: (790) AA36206

Austria, Vienna

Walter Rekirsch
Elektronische Gerate GmbH & Co.
Tel: 235555
TLX: (847) 134759

Belgium, Brussels

Fluke (Belgium) SA/NA
Tel: 2164090
TLX: (846) 26312

Brazil, Sao Paulo

Hi-Tek Eletronica Ltda.
Tel: 421-5477
TLX: (1391) 1135589

Canada, Burnaby, BC

Allan Crawford Associates Ltd.
Tel: (604) 294-1326
TLX: 0454247

Canada, Calgary, AB

Allan Crawford Associates Ltd.
Tel: (403) 291-3417
TLX: 03821186

Canada, Mississauga, ON

Allan Crawford Associates Ltd.
Tel: (416) 890-2010
TLX: 0696 1235

Canada, St. Laurent, PQ

Allan Crawford Associates Ltd.
Tel: (514) 731-8564
TLX: 05824944

Chile, Santiago

Intronica Chile Ltda.
Tel: 44940
TLX: (332) 240301

China, Peoples Republic of

Instrimpex - Fluke Service Center
Tel: 65-7281

Colombia, Bogota

Sistemas E Instrumentacion, Ltda.
Tel: 232-4532
TLX: (396) 45787

Denmark, Ballerup

Tage Olson A/S
Tel: 658111
TLX: (855) 35293

Ecuador, Quito

Proteco Coasin Cia., Ltda.
Tel: 526759
TLX: (393) 2865

Egypt and Sudan

Electronic Engineering Liaison Office
Tel: 695705
TLX: (927) 22782

England, Watford, Herts

Fluke (Great Britain) LTD
Tel: 40511
TLX: (851) 934583

Finland

Instrumentarium Elektronikka
Tel: 358-0-5281
TLX: (857) 124426

France

M.B. Electronique S.A.
Tel: 9568131
TLX: (842) 695414

Greece, Athens

Hellenic Scientific Representations
Tel: 7211140
TLX: (863) 219330

Hong Kong, Wanchai

Schmidt & Co (H.K.) Ltd.
Tel: 8330-222
TLX: (780) 74766

India, Bangalore

Hinditron Services Pvt. Ltd.
Tel: 33139
TLX: (953) 845741

India, Bombay

Hinditron Services Pvt. Ltd.
Tel: 8121316
TLX: (953) 112326

India, New Delhi

Hinditron Services Pvt. Ltd.
Tel: 640380
TLX: (953) 316458

Indonesia, Jakarta Pusat

P.T. Dwi Tunggal Jaya Sakti
Tel: 584685
TLX: (796) 47308

Israel, Ramat Hasharon

R.D.T. Electronics Engineering Ltd.
Tel: 483211
TLX: (922) 32143

Italy, Milan

Sistrel S.p.A.
Tel: 6181893
TLX: (843) 334643

Japan, Tokyo

John Fluke Mfg. Co., Inc.
Japan Branch
Tel: 434-0181
TLX: (781) 242-4331

Korea, Republic of

Electro-Science Korea Co.
Tel: 784-9942
TLX: MYOUNG K24283

Malaysia, Petaling Jaya

Mecomb Malaysia SDN BHD
Tel: 743422
TLX: (784) MA37764

Mexico

Industrial, S.A. (Mexel)
Diagonal No. 27
Entre Calle de Eugenia Y Ave.
Colonia del Valle
C.P. 03100, Mexico
Tel: 660-4323
TLX: (383) 1771038

Netherlands, Tilburg

Fluke (Nederland) B.V.
Tel: 352455
TLX: (844) 52683

New Zealand, Auckland

McLean Information Technology, Ltd.
Tel: 501-801, 501-219
TLX: (791) 21570

Norway, Oslo

Morgenstjerne & Co. A/S
Tel: 356110
TLX: (856) 71719

Pakistan, Karachi

International Operations (PAK), Ltd.
Tel: 221127, 239052
TLX: (952) 24494

Peru, Lima

Importaciones Y Representaciones
Electronicas S.A.
Tel: 288650
TLX: (394) 25663

Philippines, Republic of

Spark Radio & Electronics Corp.
Tel: 775192
TLX: (722) 27901

Portugal, Lisbon

Decada Espectral Equipamentos
de Electronica, Lda.
Tel: 2103420
TLX: (832) 15515

Republic of Singapore, Singapore

Rank O'Connor's (PTE) Limited
Tel: 4737944
TLX: (786) RS21023

Republic of South Africa

Fluke S.A. (Pty) Ltd.
Tel: 786-3170
TLX: (960) 424328

Spain, Madrid

Equipos y Sistemas S.A.
Tel: 458-0150
TLX: (831) 42856

Sweden, Vallingby

Teleinstrument AB
Tel: 380370
TLX: (854) 15770

Switzerland, Zurich

Traco Electronic AG
Tel: 2010711
TLX: (845) 815570

Taiwan, Taipei

Schmidt Electronics Corp.
Tel: 5013468
TLX: (785) 11111

Thailand, Bangkok

Measuretronix Ltd.
Tel: 378-2516
TLX: (788) 82796

Turkey, Istanbul

Erkman Elektronik Aletler
Tel: 4415461
TLX: (821) 24399

Uruguay, Montevideo

Coasin Uruguaya S.A.
Tel: 789015
TLX: (398) UY23010

Venezuela, Caracas

Coasin C.A.
Tel: 239-0967
TLX: (395) 21027

West Germany, Ismaning/Munich

Fluke (Deutschland) GmbH
Tel: 96050
TLX: (841) 0522472



Appendix 7A

Manual Change Information

7A-1. INTRODUCTION

This appendix contains information necessary to backdate the manual to conform with the earlier PCA configurations. To identify the configuration of the PCAs used in your instrument, refer to the revision letter (marked in ink) on the component side of each PCA. Table 7A-1 defines the assembly revision levels documented in this manual.

As changes and improvements are made to the instrument, they are identified by incrementing the revision letter marked on the affected PCA. These changes are documented on a supplemental change/errata sheet which, when applicable, is inserted at the front of the manual. To identify the configuration of the PCAs used in your Generator, refer to the revision letter on the component side of each PCA.

7A-2. BACKDATING INSTRUCTIONS

To backdate this manual to conform with an earlier assembly revision level, perform the changes indicated in Table 7A-1. If this manual documents all PCAs at their original level, no changes are necessary, and no changes will be indicated in Table 7A-1.

Section 8

Schematic Diagrams

FIGURE	TITLE	PAGE
8-1.	Mnemonics	8-2
8-2.	Schematic Symbols	8-3
8-3.	Synthesizer Block Diagram	8-5
8-4.	Output Block Diagram	8-6
8-5.	A1A1 Display PCA	8-7
8-6.	A2A1 Synthesizer PCA	8-10
8-7.	A2A2 VCO PCA	8-15
8-8.	A2A4 Output PCA	8-16
8-9.	A2A5A4 Attenuator/RPP PCA	8-21
8-10.	A2A5A5 Relay Driver/RPP PCA	8-22
8-11.	A2A7 Controller PCA	8-24
8-12.	A3A1 Power Supply PCA	8-28
8-13.	A3A3A1 IEEE-488 Interface PCA	8-29
8-14.	A4A1 Discriminator PCA	8-30
8-15.	A4A2 Analog/Digital PCA	8-32

SCHEMATIC DIAGRAMS

MNEMONIC	DESCRIPTION	SIGNAL TYPE *
A 0-15	Address	B
A12DB	Attenuator 12-dB Section Control	L
A24(1-5)	Attenuator 24-dB Section Controls	L
A6DB	Attenuator 6-dB Section Control	L
BAB 0-3	Module Section Address	H
BD 0-7	Module Section Data	B
BSEL 0.1	Module Section Select	L
CKN	N-Divider Clock	L
CLR	Display Clear	L
CONVERT	Deviation Meter A/D Convert Pulse	H
D 0-7	Data	B
DATAVAL	Deviation Meter Data Valid	H
DBIN	Read Enable	L
DD 0-7	Display Data	B
DIG	Display Digit Select	L
DR	Deviation Meter A/D Data Ready	L
EXREF	External Reference Control	L
EXTAM	External AM Control	L
EXTFM	External FM Control	L
FIL 1.2	Display Filament Supply	AC+DC
FM 0-9	FM Deviation DAC Control	H
FMEN	FM Enable	H
FMRNG 0-2	FM Range Control	H
FMV	FM Audio	AF
HAOCT	Half-Octave Control	H
HET	Het (Low) Band Control	L
HSOPT	High-Stability Option Installed	L
IEA 13-15	IEEE Address Bus	B
IEADR	IEEE Address Latch Enable	L
IECS	IEEE Chip Enable	L
IED 0-7	IEEE Data Bus	B
IEDB	IEEE Read Enable	L
IEIN	IEEE Option Installed	L
IEINT	IEEE Interrupt	L
IEW	IEEE Write Enable	L
INTAM	Internal AM Control	L
INTFM	Internal FM Control	L
KBIN	Keyboard Input Select	H
KN 0-9	PLL Gain Compensation DAC	H
KNV	Main PLL Gain Compensation Voltage	DC
KV 0-9	VCO Compensation DAC Control	H
LEV 0-11	RF Level DAC Control	H
LRFM	Low-Rate FM Option Installed	L
METERON	Deviation Meter On	H
MF400	Modulation Frequency Control	L
MID	Mid Band Control	L
MLEVHI	External Modulation High-Level Status	H
MLEVLO	External Modulation Low-Level Status	H
MODE	Triple-Modulus Prescaler	L
NVCS	NVM RAM Chip Select	L
NVEN	NVM Enable	L
NVIN	NVM Option Installed	L
POSPEAK	Deviation Meter Positive Peak	L
RIN	10-MHz Output Buffer Enable	H
RMUXD.1	Reference Multiplexer Select	H
RNG50K	Deviation Meter 50 kHz Range	H
ROPT	Rear Output Option Installed	L
RPP	RPP Option Installed	L
RPRST	RPP Reset Control	H
RPTRP	RPP Tripped Status	L
SEG 1-3.9	Display Segment Select	L
SHEN	Sub-Harmonic Reference Control	L
SHET	Synthesizer Heterodyne Control	L
SHREF	Sub-Harmonic Ref Option Installed	L
SHTUNE	Sub-Harmonic Ref Tuning Voltage	DC
TBOUT	Output Test Bit	H
TBSYN	Synthesizer Test Bit	H
TRIG	Deviation Meter Trigger	H
TRMOD	Triple-Modulus Prescaler Select	L
TRSEQ	Remote Sequence Trigger	L
TUNE	Main PLL Tuning Voltage	DC
UNLCK	PLL Unlocked or Overmodulated Status	L
UNLVL	ALC Loop Unleveled Status	L
WE	Write Enable	L
XOEN	10-MHz Crystal Oscillator Control	L

* Six SIGNAL types are listed in the following:

DC= DC Control
AC= Line Frequency
AF= Audio (modulation) Signal
L = Logic (binary) signal, active low at the source
H = Logic (binary) signal, active high at the source
B = Dynamic bus

Figure 8-1. Mnemonics











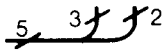
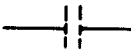

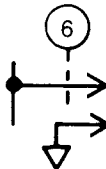
Multitpath Interconnection		Printed Capacitor	
Dual-Pin Connector Service Aid		Feed-Through Capacitor	
Dual-Pin Connector Test Point		Diode, General	
Test Point 4		Diode, Varactor	
Test Point 5, no post		Diode, Pin	
Microstrip Transmission Line		Diode, Zener	
Stripline Transmission Line		Diode, Schottky	
Printed Inductor		Factory Selected value	*

Figure 8-2. Schematic Symbols

SCHEMATIC DIAGRAMS

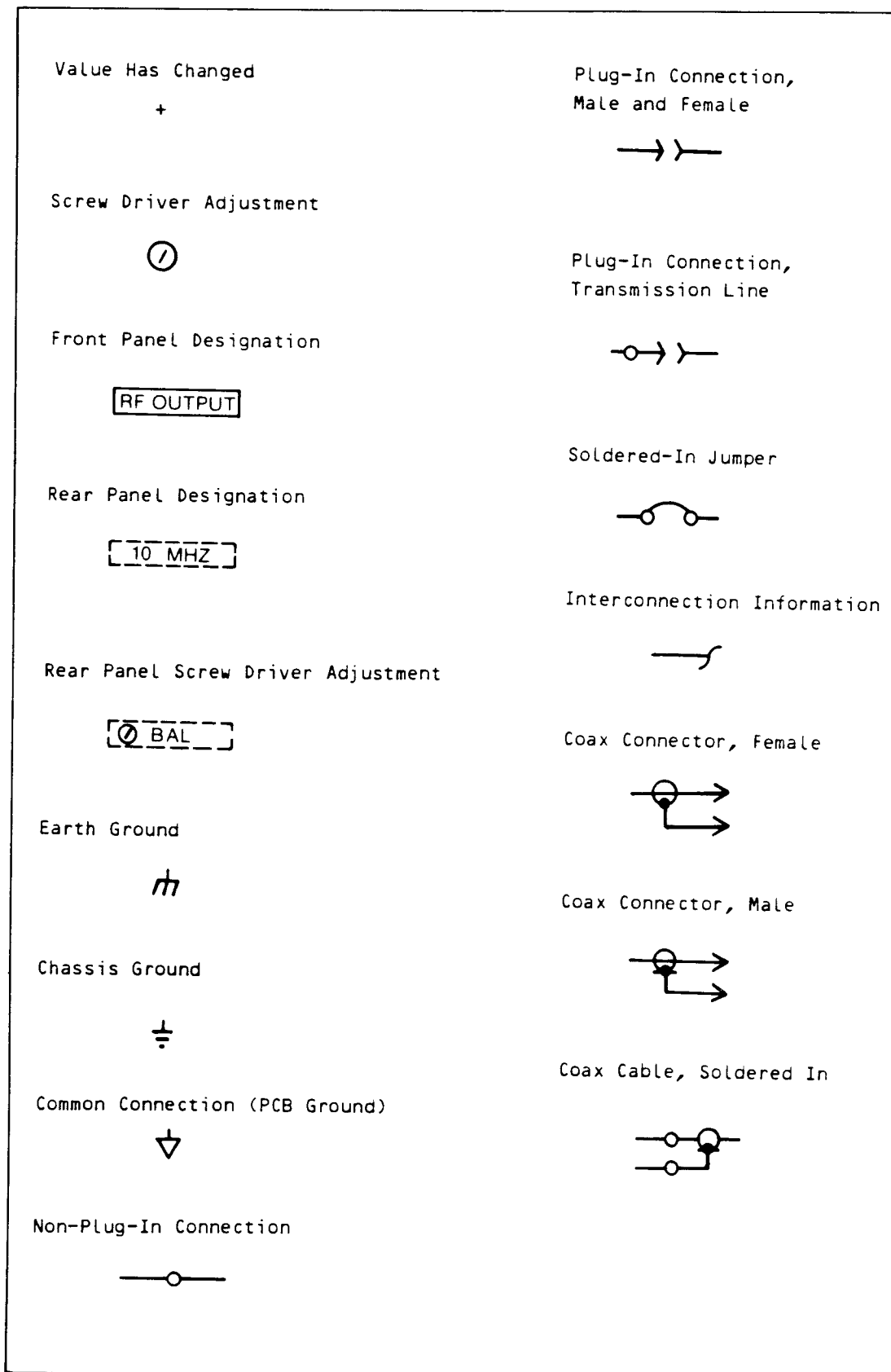

Figure 8-2. Schematic Symbols (cont)

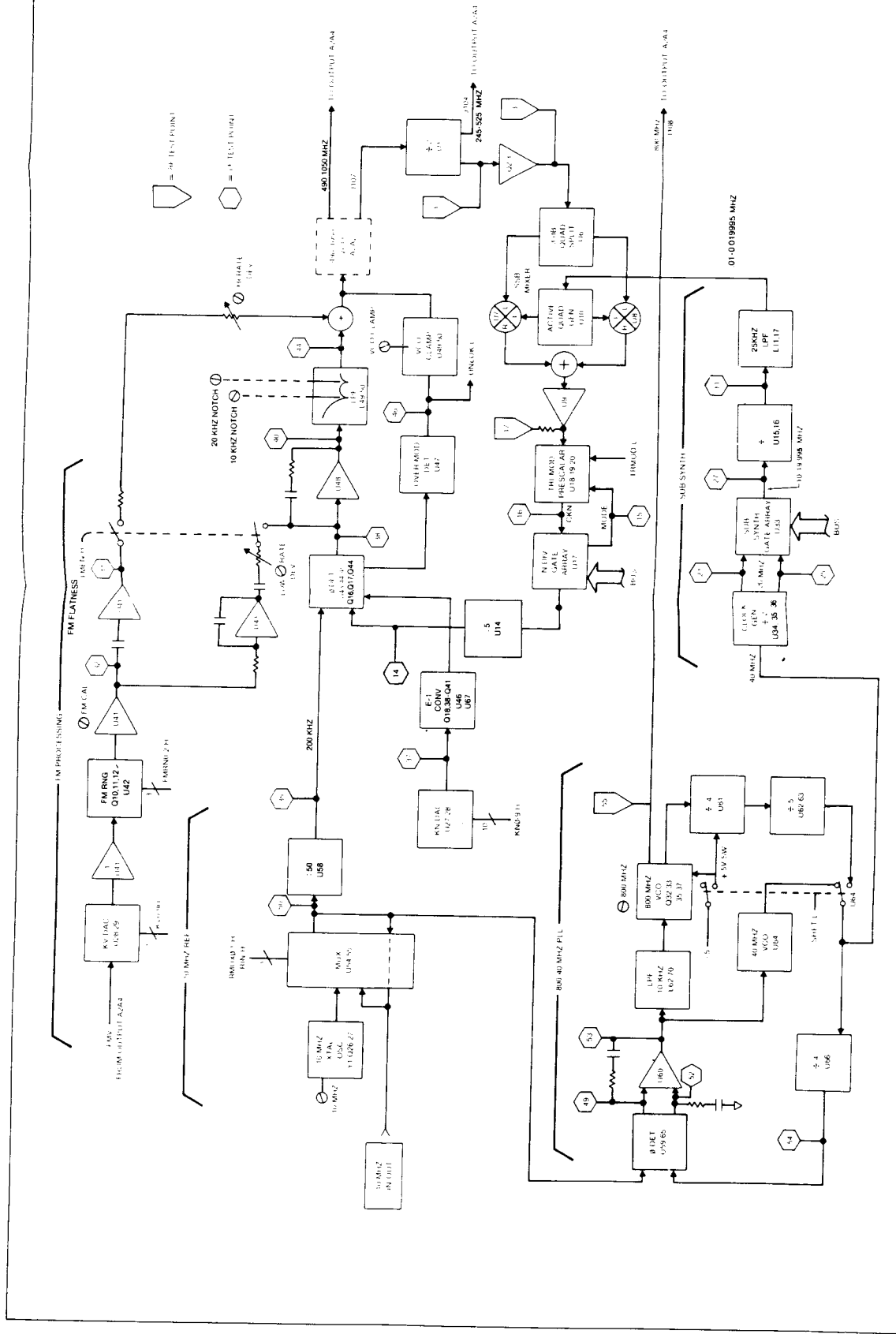

Figure 8-3. Synthesizer Block Diagram

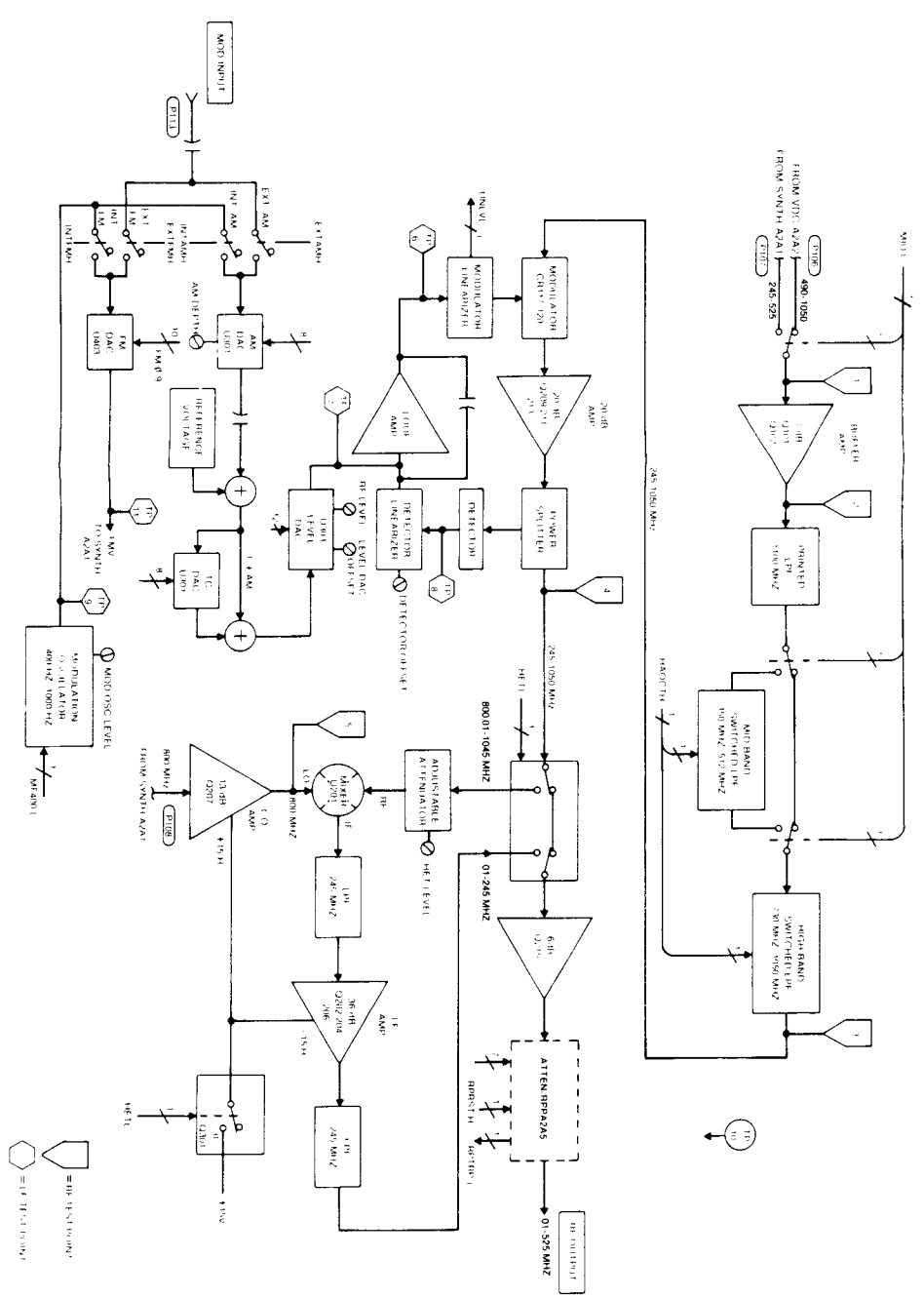
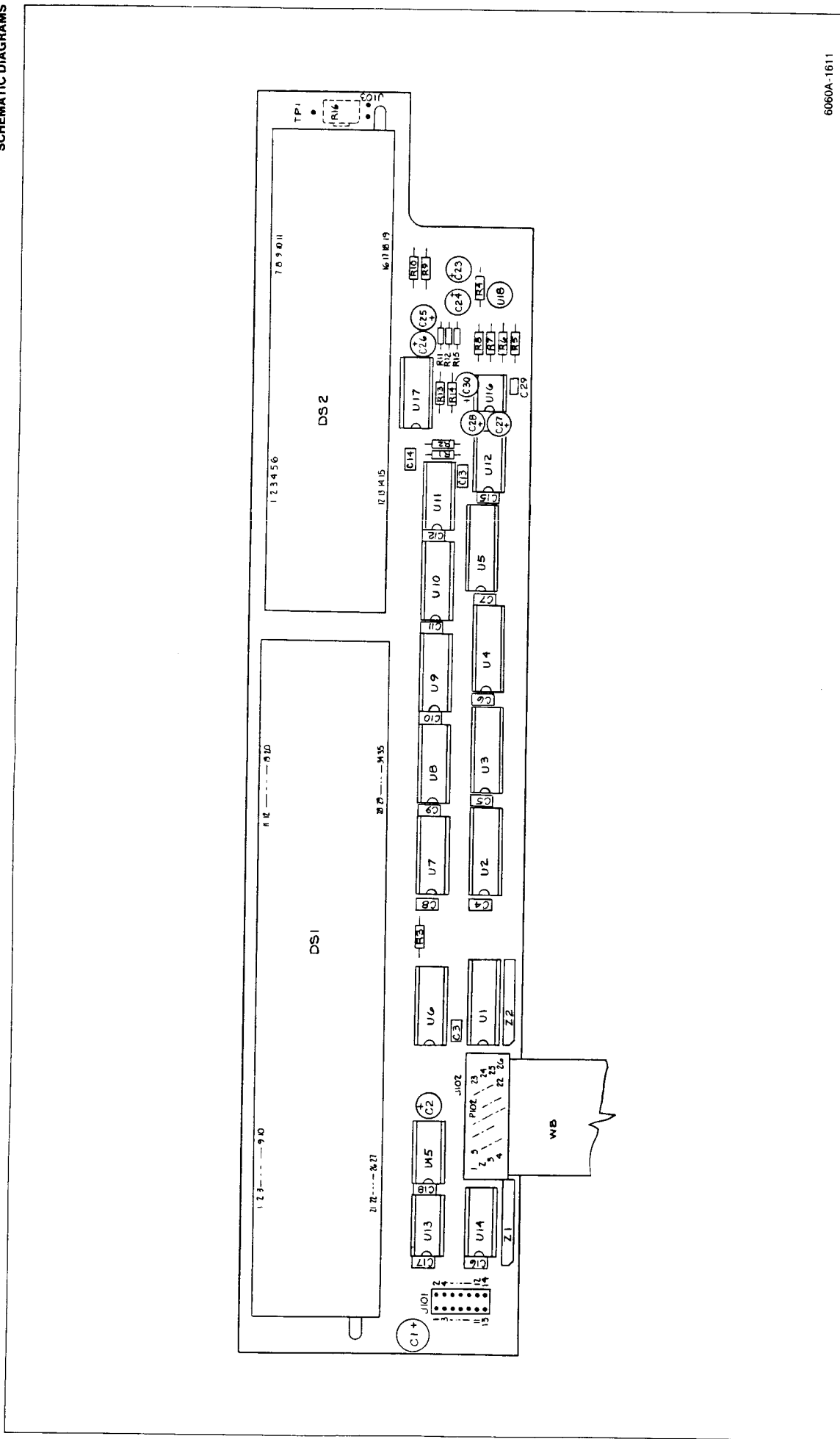

Figure 8-4. Output Block Diagram

SCHEMATIC DIAGRAMS



6060A-1611

Figure 8-5. A1A1 Display PCA

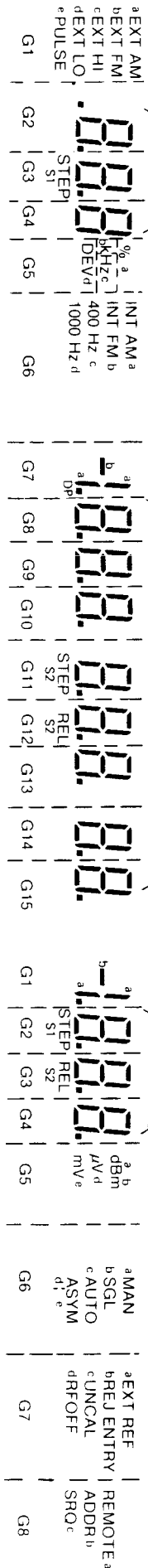
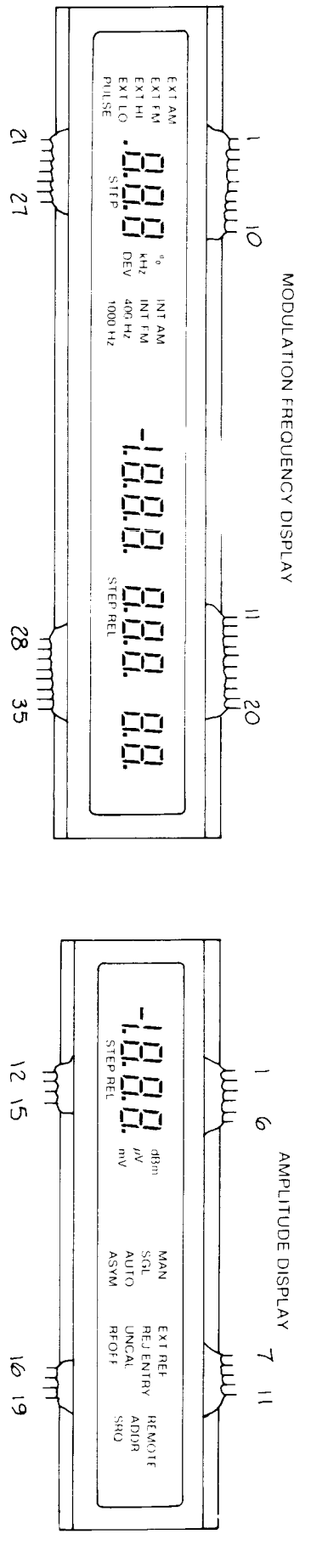

PIN NO	1	2	3	4	5	6	7	8	9	10	11	12	13	14	15	16	17	18	19	20
CONNECTION	F	S ₁	P	P	P	C	C	P	P	P	P	P	P	P	P	P	P	P	P	F

PIN NO	1	2	3	4	5	6	7	8	9	10	11	12	13	14	15	16	17	18	19	20
CONNECTION	F	P	P	P	P	P	P	P	P	P	F	S ₁	S ₂	S ₂	S ₂	S ₂	S ₂	S ₂	S ₂	S ₂

NOTES

- F Denotes Filament
- G Denotes Grid (numeric suffix identifies display field)
- P Denotes Plate (subscript identifies display segment)

DISPLAY CONNECTION INFORMATION

Figure 8-5. A1A1 Display PCA (cont)

SCHEMATIC DIAGRAMS

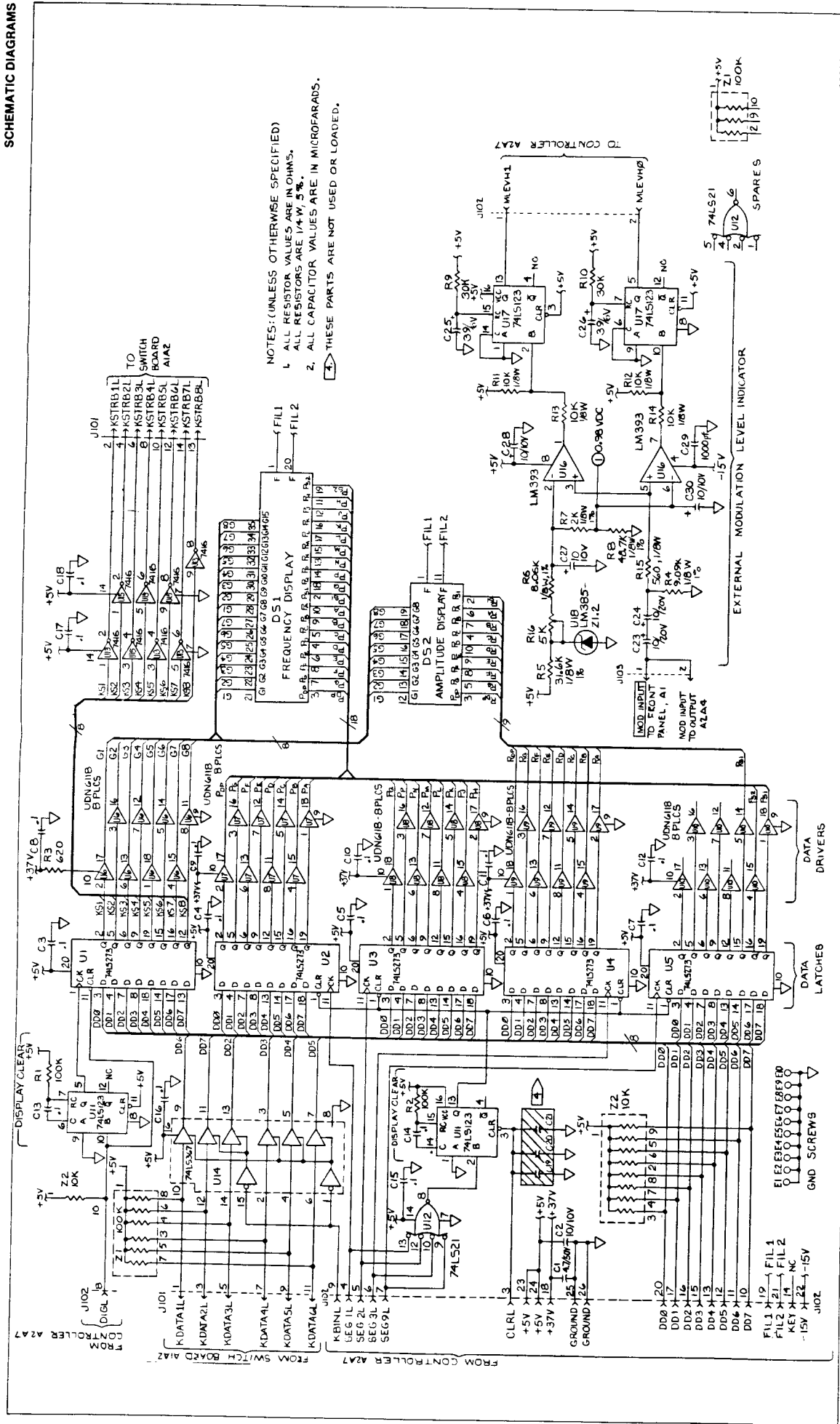

6060A-1011

Figure 8-5. A1A1 Display PCA (cont)

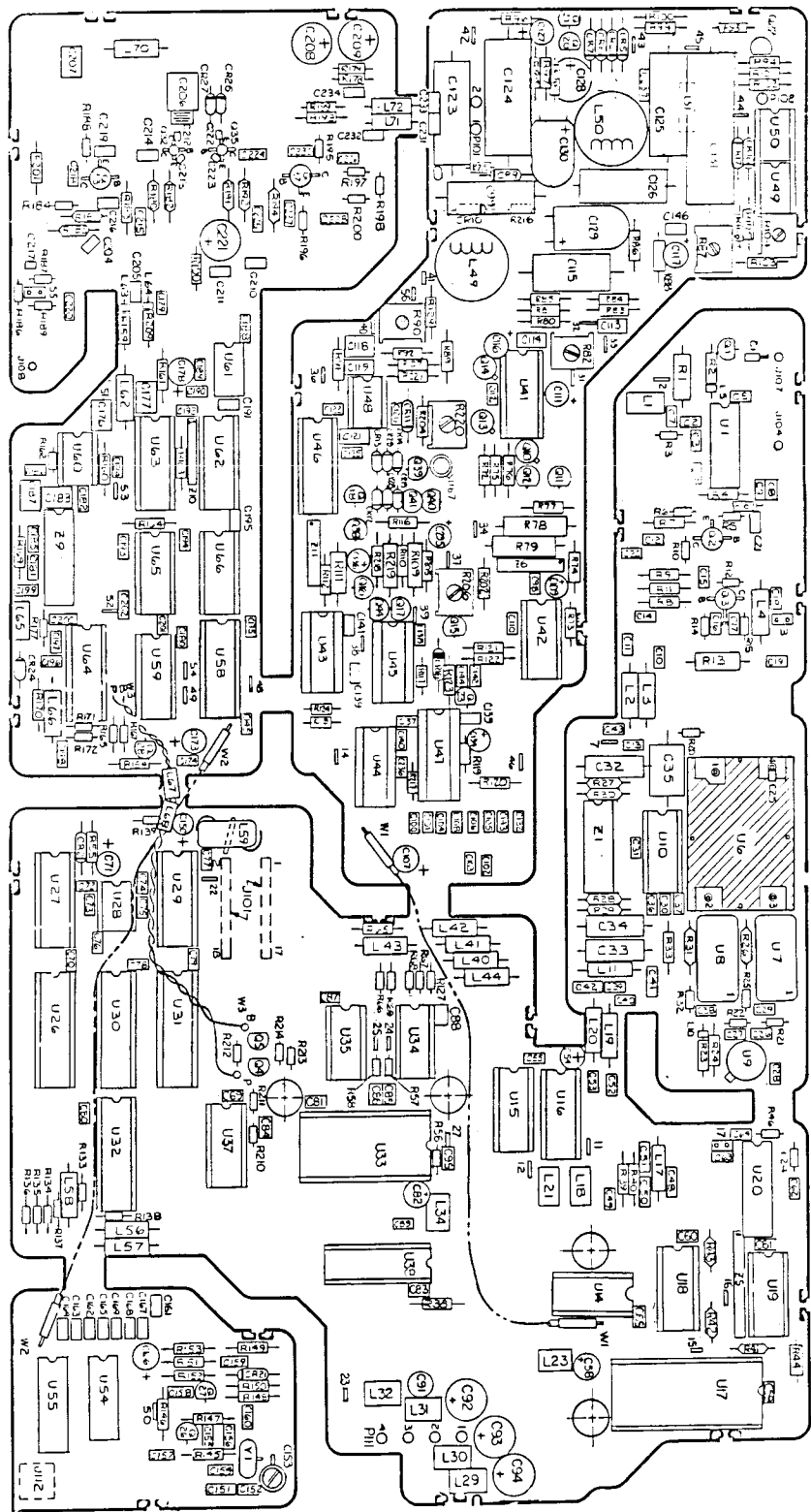
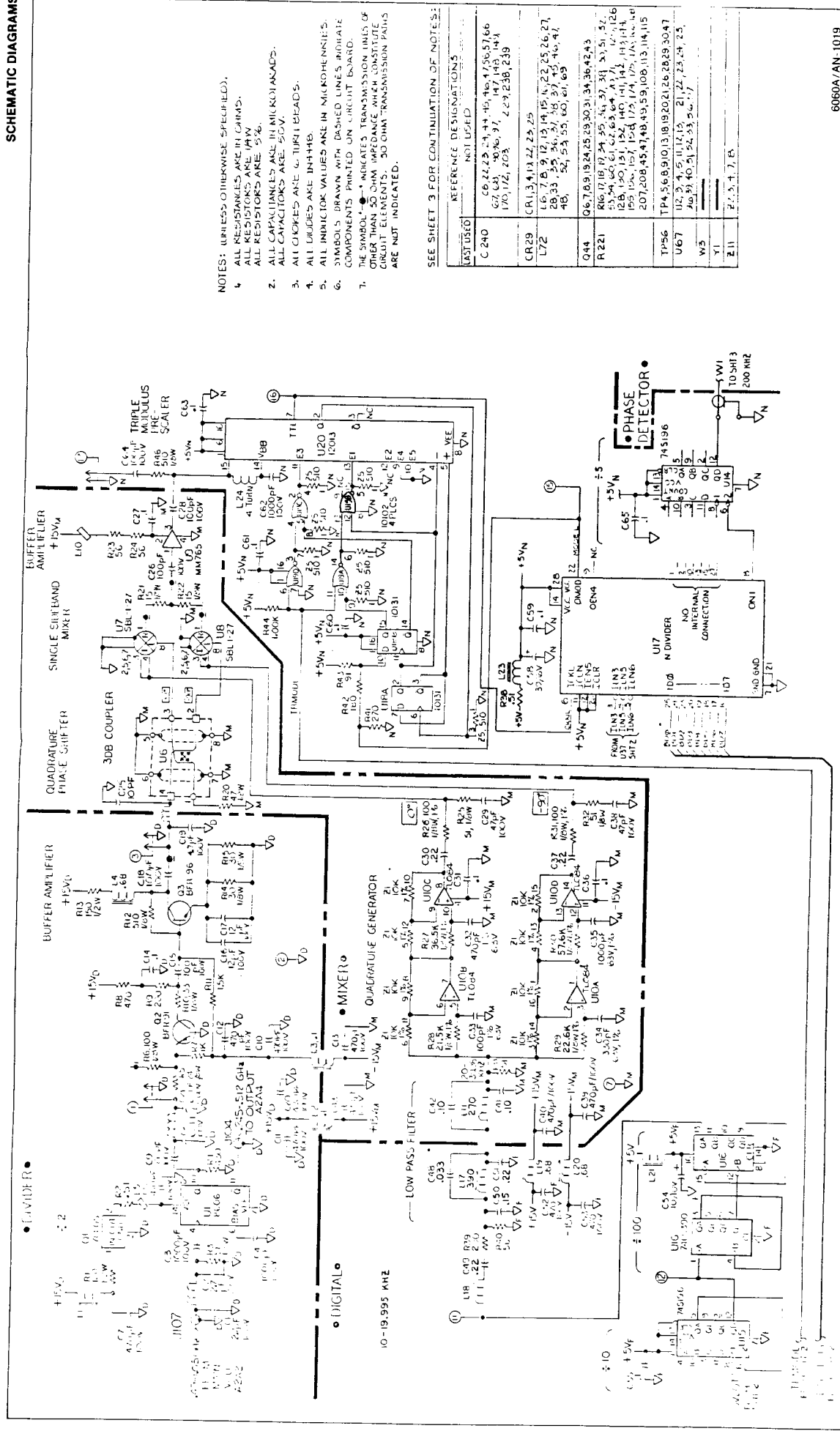

Figure 8-6. A2A1 Synthesizer PCA

SCHEMATIC DIAGRAMS



- NOTES:** (UNLESS OTHERWISE SPECIFIED)
- ALL RESISTANCES ARE IN OHMS.
 - ALL RESISTORS ARE 1/4W.
 - ALL CAPACITANCES ARE IN MICROGRAMS.
 - ALL CAPACITORS ARE 50V.
 - ALL COILS ARE 1/4 TURN BEADS.
 - ALL INDUCTORS ARE 100H.
 - SYMBOLS DRAWN WITH DASHED LINES INDICATE COMPONENTS PRINTED ON CIRCUIT BOARD.
 - THE SYMBOL \bullet INDICATES TRANSMISSION LINES OF OTHER THAN 50 OHM IMPEDANCE WHICH CONSTITUTE CIRCUIT ELEMENTS. 30 OHM TRANSMISSION LINES ARE NOT INDICATED.

SEE SHEET 3 FOR CONTINUATION OF NOTES:

FAST USED	REFERENCE DESIGNATIONS	NOT USED
C 240	C6, 22, 23, 24, 25, 26, 27, 28, 33, 35, 37, 41, 42, 43, 44, 45, 46, 47, 48, 170, 171, 203	C1, 3, 4, 13, 22, 23, 25
CR29	CR1, 3, 4, 13, 22, 23, 25	L6, 7, 8, 9, 12, 13, 14, 15, 16, 22, 23, 26, 27, 28, 33, 35, 37, 41, 42, 43, 44, 45, 46, 47, 48
L72	L6, 7, 8, 9, 12, 13, 14, 15, 16, 22, 23, 26, 27, 28, 33, 35, 37, 41, 42, 43, 44, 45, 46, 47, 48	Q44
Q44	Q6, 7, 8, 9, 13, 25, 29, 30, 31, 34, 36, 42, 43	R221
R221	R16, 17, 18, 19, 20, 21, 22, 23, 24, 25, 26, 27, 28, 29, 30, 31, 32, 33, 34, 35, 36, 37, 38, 39, 40, 41, 42, 43, 44, 45, 46, 47, 48, 140, 141, 142, 143, 144, 145, 146, 147, 148, 149, 150, 151, 152, 140, 141, 142, 143, 144, 145, 146, 147, 148, 149, 150, 151, 152, 173, 174, 175, 176, 177, 207, 208, 45, 47, 48, 49, 59, 108, 113, 114, 115	TP56
TP56	TP4, 5, 6, 8, 9, 10, 13, 18, 19, 20, 21, 26, 28, 29, 30, 47	U67
U67	U2, 3, 4, 5, 11, 12, 13, 20, 21, 22, 23, 24, 25	Y1
Y1	Y0, 3, 40, 51, 52, 53, 54, 55, 56, 57	Z11
Z11	Z1, 2, 3, 4, 7, 8	

Figure 8-6. A2A1 Synthesizer PCA (cont)

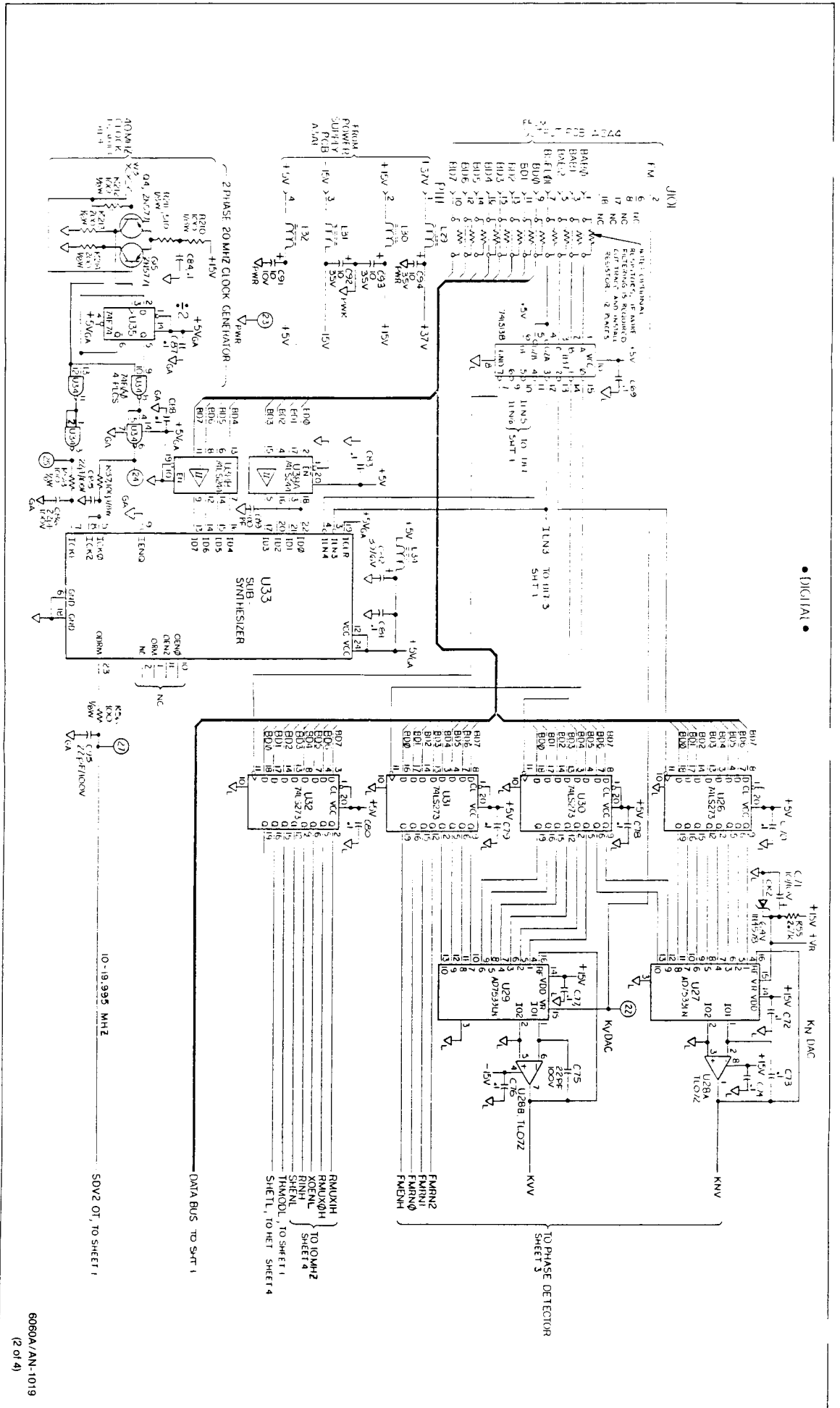
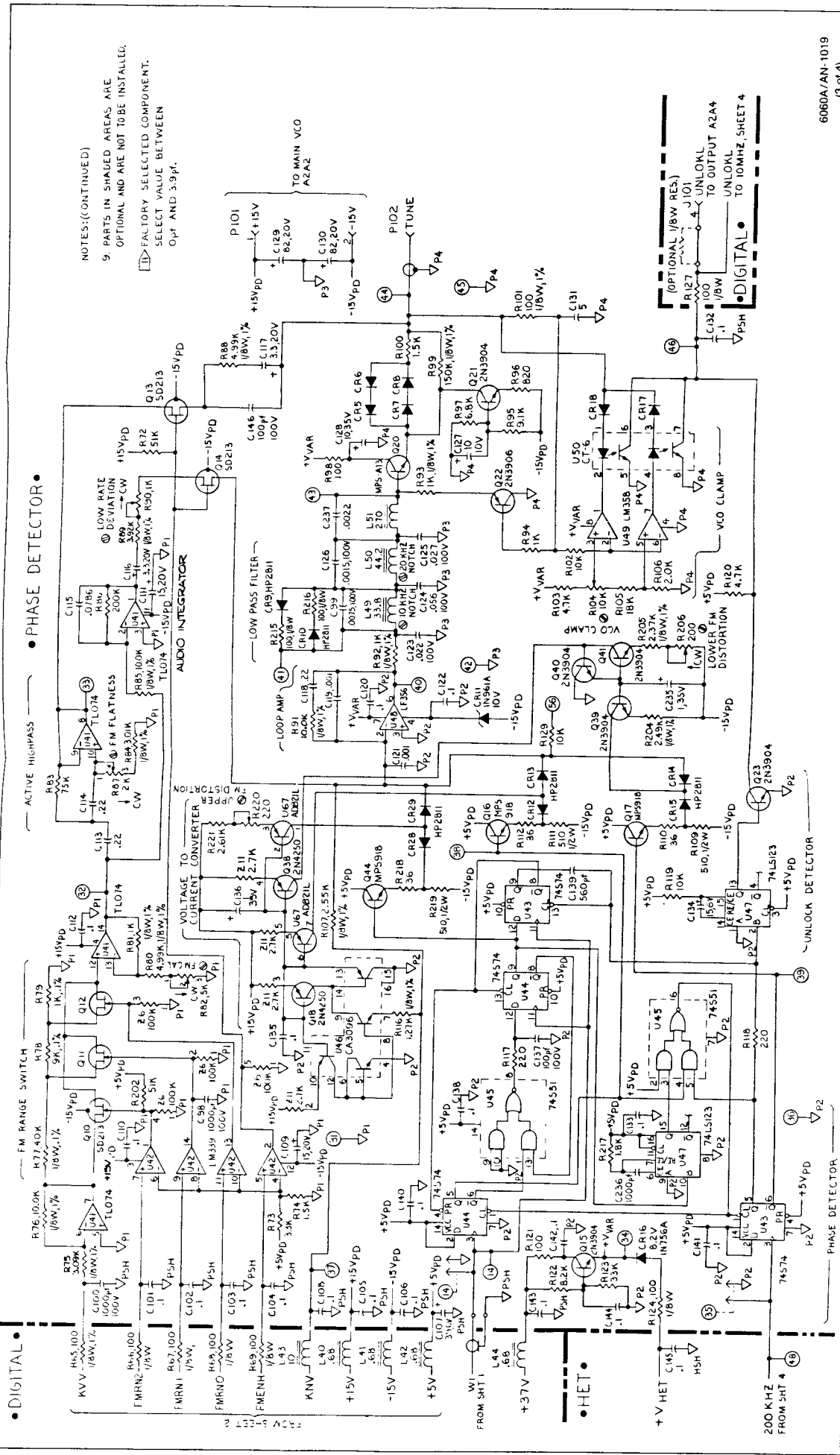

Figure 8-6. AZA1 Synthesizer PCA (cont)



NOTES: (CONTINUED)
 9. PARTS IN SHADED AREAS ARE OPTIONAL AND ARE NOT TO BE INSTALLED.
 □ FACTORY SELECTED COMPONENT.
 ○ SELECT VALUE BETWEEN 0.1μF AND 3.9μF.

Figure 8-6. AZA1 Synthesizer PCA (cont)

SCHEMATIC DIAGRAMS

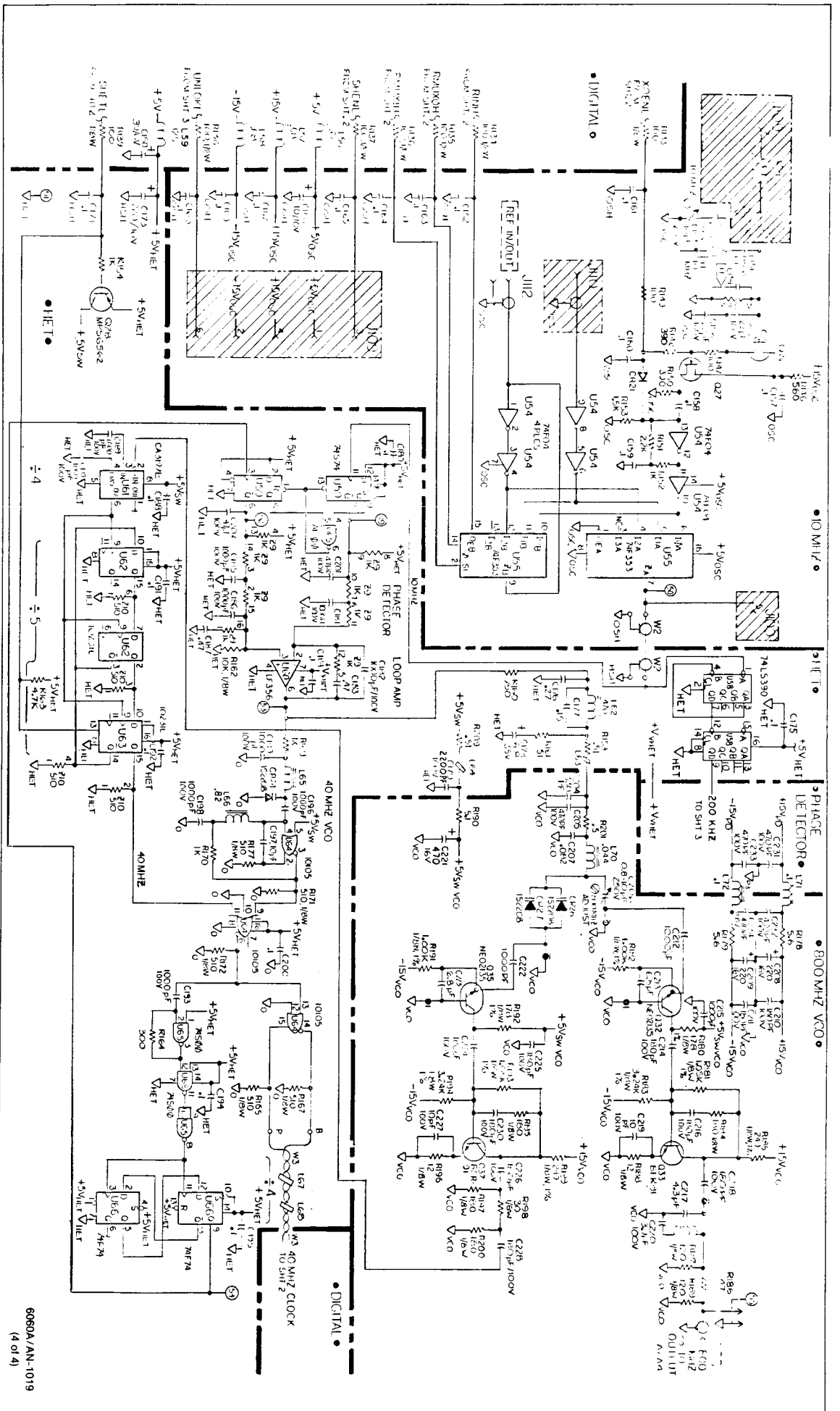
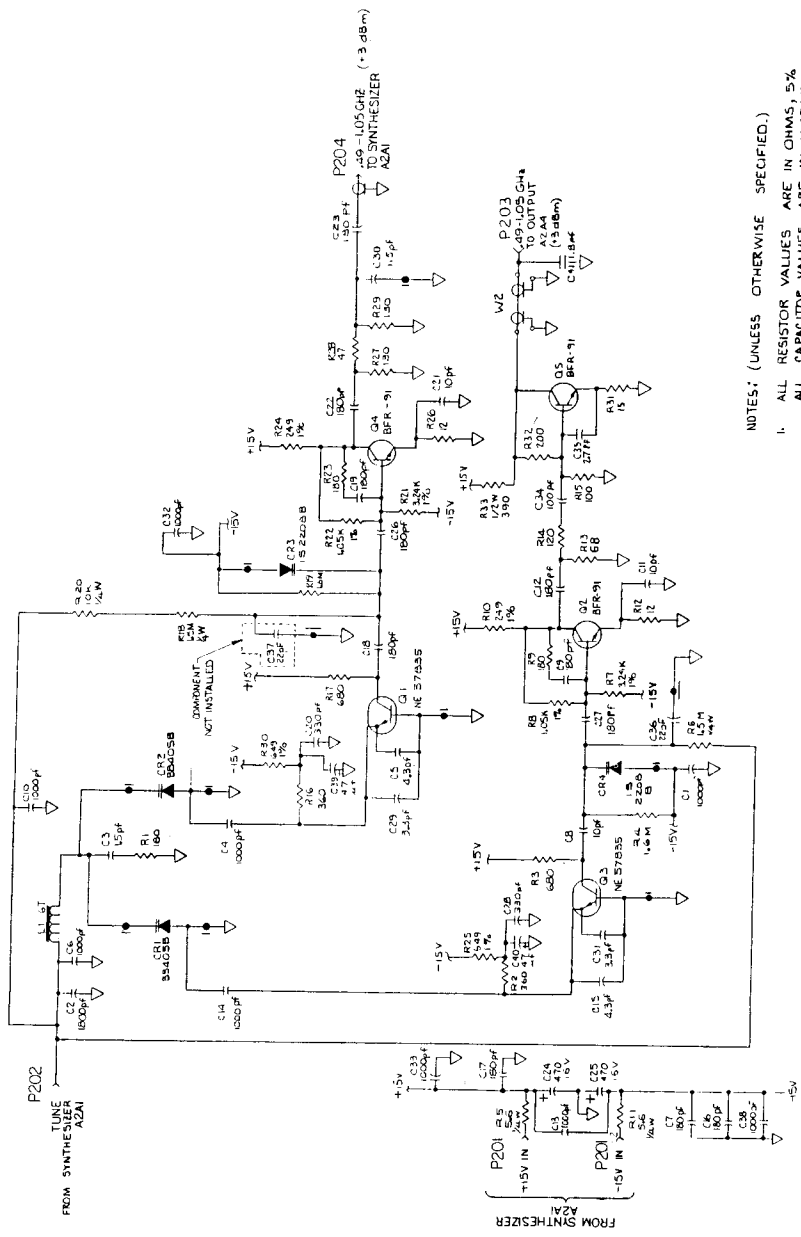
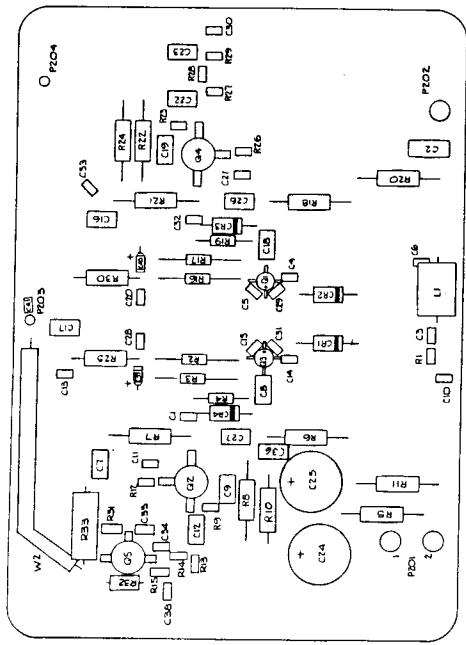

Figure 8-6. 42A1 Synthesizer PCA (cont)



- NOTES: (UNLESS OTHERWISE SPECIFIED.)
1. ALL RESISTOR VALUES ARE IN OHMS, 5%
 2. ALL CAPACITOR VALUES ARE IN MICROFARADS.
 3. ALL RESISTORS ARE 1/8W.

REFERENCE DESIGNATIONS	LAST USED	NOT USED
R33		P1, Z00
C-11		
C5		
CR-4		
P-204		
W-2		



6060A-1618

Figure 8-7. A2A2 VCO PCA

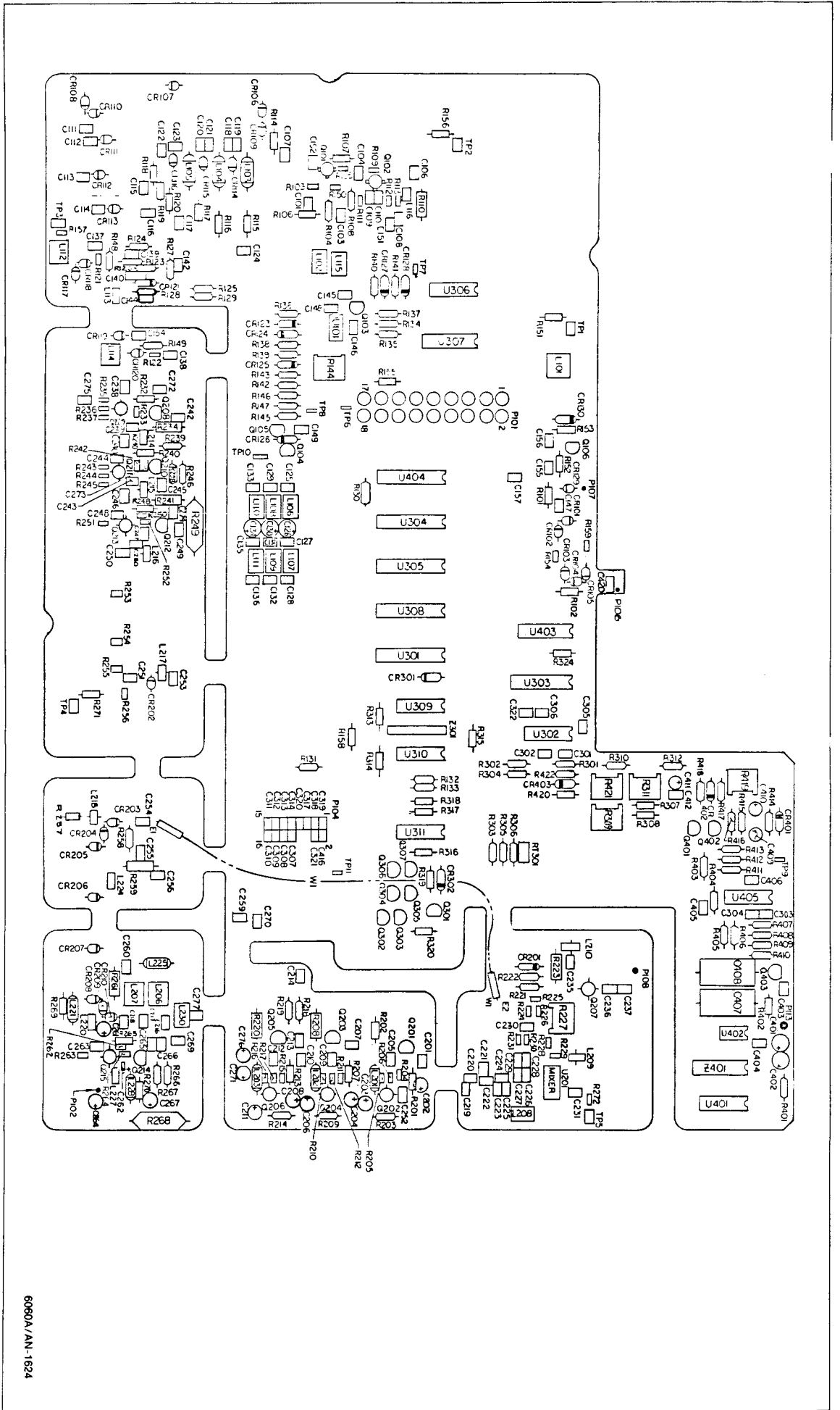
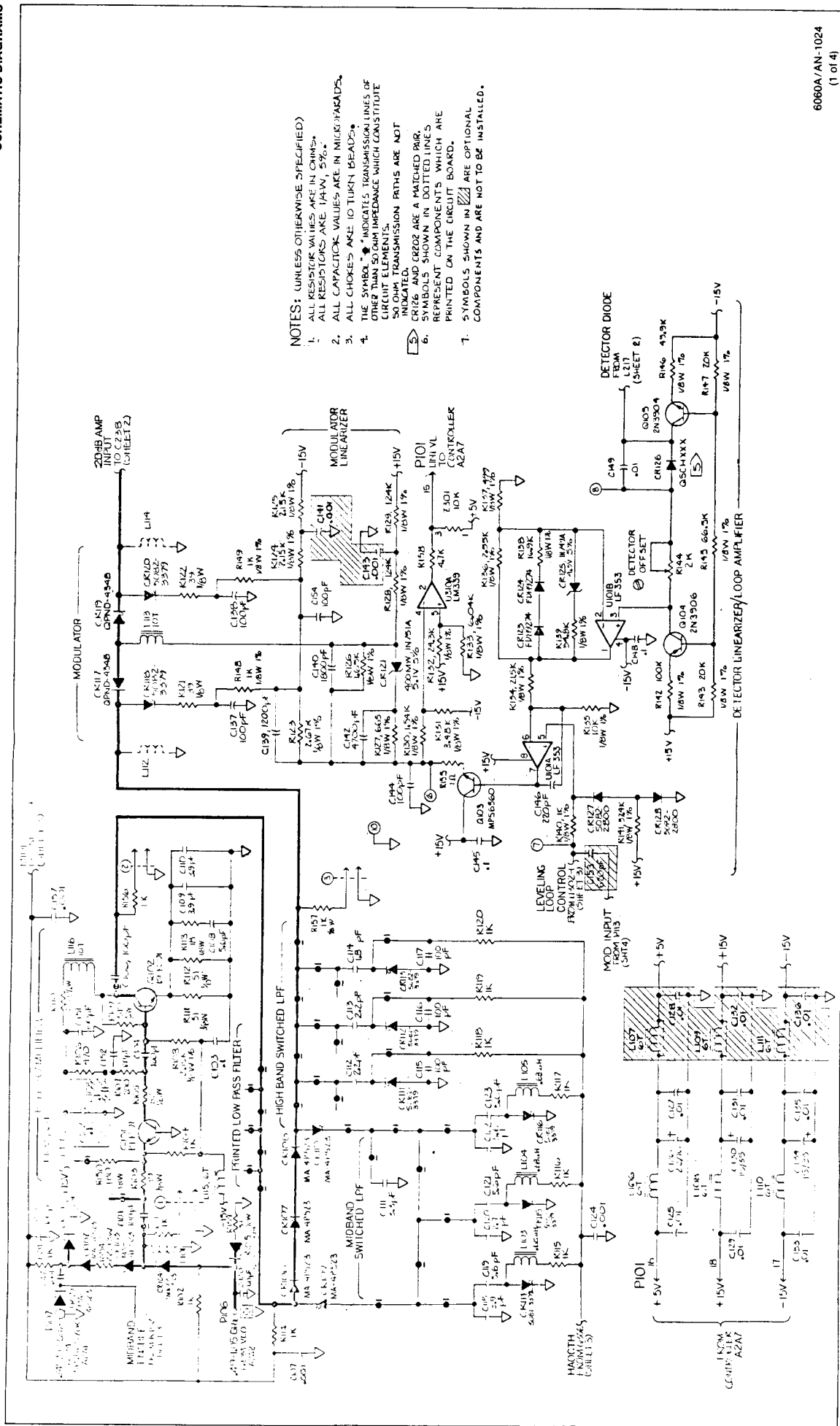

Figure 8-8. AZA4 Output PCA



- NOTES: (UNLESS OTHERWISE SPECIFIED)
1. ALL RESISTOR VALUES ARE IN OHMS. ALL RESISTORS ARE 1/4W, 5%. *
 2. ALL CAPACITOR VALUES ARE IN MICROFARADS.
 3. ALL CHOKES ARE 10 TURN BEADS. *
 4. THE SYMBOL * INDICATES TRANSMISSION LINES OF OTHER THAN 50 OHM IMPEDANCE WHICH CONSTITUTE CIRCUIT ELEMENTS.
 5. UNMATCHED CIRCUITS ARE NOT TO BE INSTALLED.
 6. SYMBOLS SHOWN IN DOTTED LINES REPRESENT COMPONENTS WHICH ARE PRINTED ON THE CIRCUIT BOARD.
 7. SYMBOLS SHOWN IN [] ARE OPTIONAL COMPONENTS AND ARE NOT TO BE INSTALLED.

Figure 8-8. A2A4 Output PCA (cont)

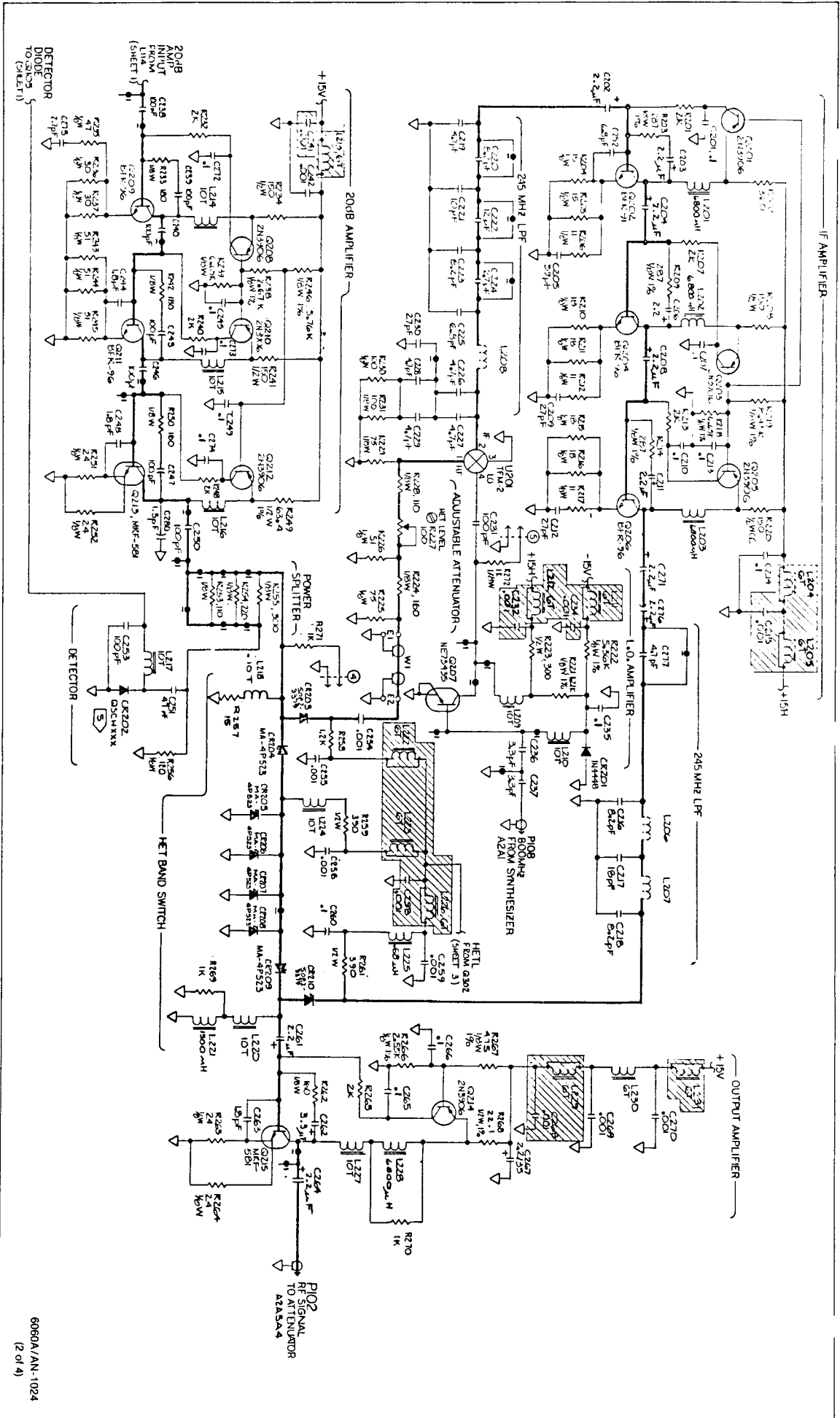
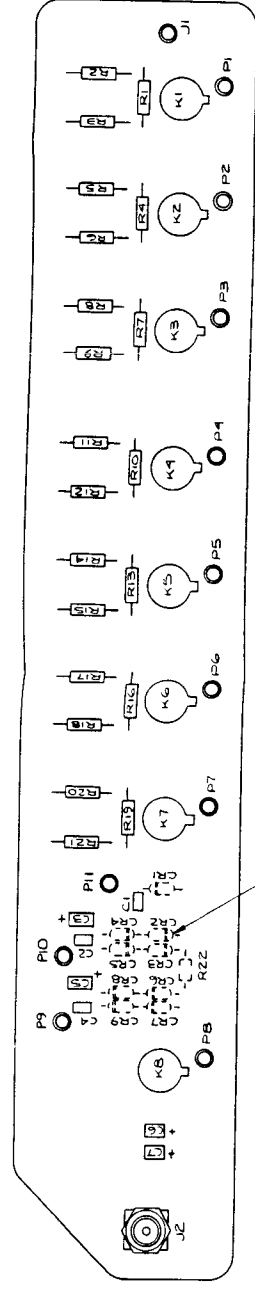

Figure 8-8. A2A4 Output PCA (cont.)



6060A-1647

ALL COMPONENTS SHOWN IN DASHED LINES ARE MOUNTED ON FAR SIDE.

FROM RELAY DRIVER/RPP CONTROLLER AZASAS

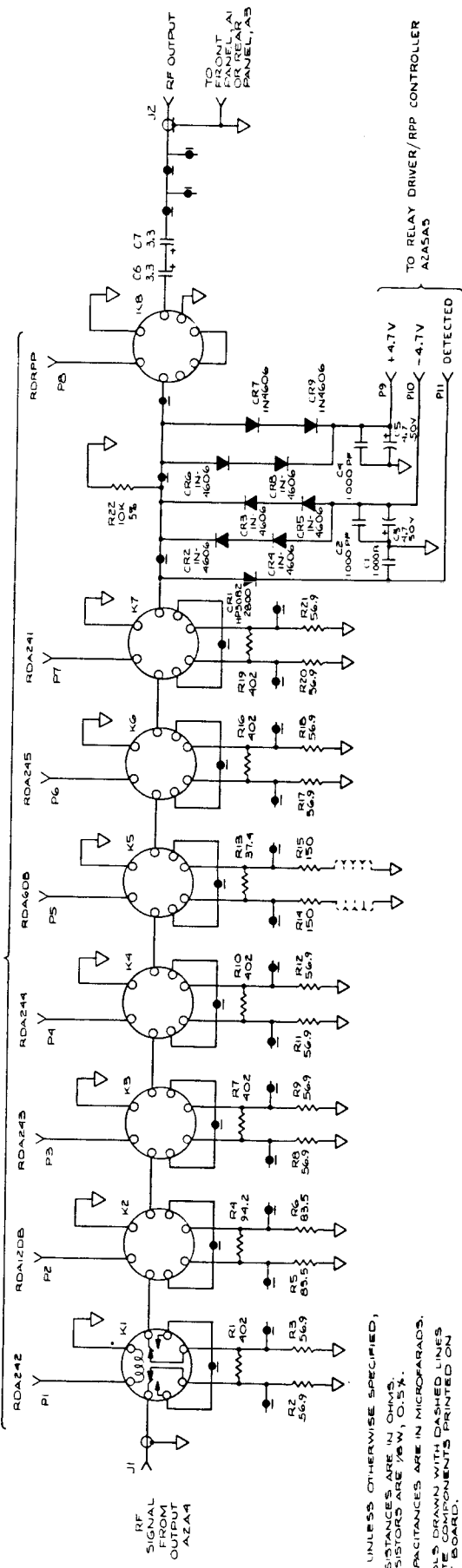

REFERENCE DESIGNATIONS	HIGHEST	NOT USED
P11		
K6		
R22		
CR9		
J2		

- NOTES: UNLESS OTHERWISE SPECIFIED,
1. ALL RESISTANCES ARE IN OHMS.
 2. ALL CAPACITANCES ARE IN MICROFARADS.
 3. SYMBOLS DRAWN WITH DASHED LINES INDICATE COMPONENTS PRINTED ON CIRCUIT BOARD.
 4. THE SYMBOL INDICATES TRANSMISSION LINE CHARACTERISTICS WHICH CONSTITUTE A 50 OHM TRANSMISSION PATHS ARE NOT INDICATED.
 5. FOR ASSEMBLY SEE 6060A-1647
 6. FOR REFERENCE DESIGNATIONS SEE 6060A-1647.

6060A-1047

Figure 8-9. A2A5A4 Attenuator/RPP PCA

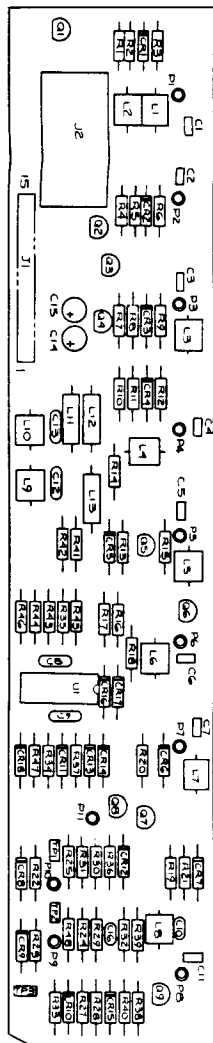

6060A-1645

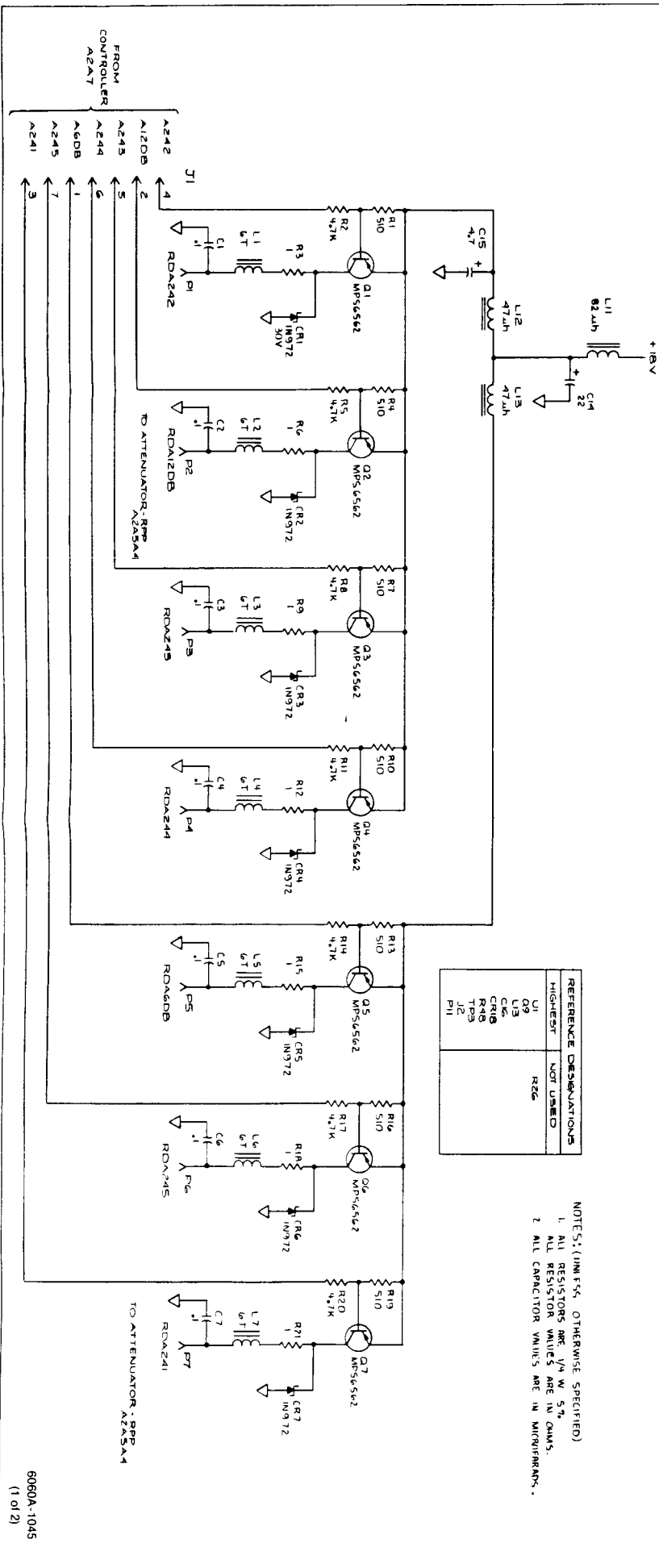

NOTE 5: (MIN FSS, OTHERWISE SPECIFIED)
 1. ALL RESISTORS ARE 1/4 W 5%
 ALL RESISTOR VALUES ARE IN OHMS.
 2. ALL CAPACITOR VALUES ARE IN MICROFARADS.

Figure 8-10. AZAS45 Relay Driver/RPP PCA

SCHEMATIC DIAGRAMS

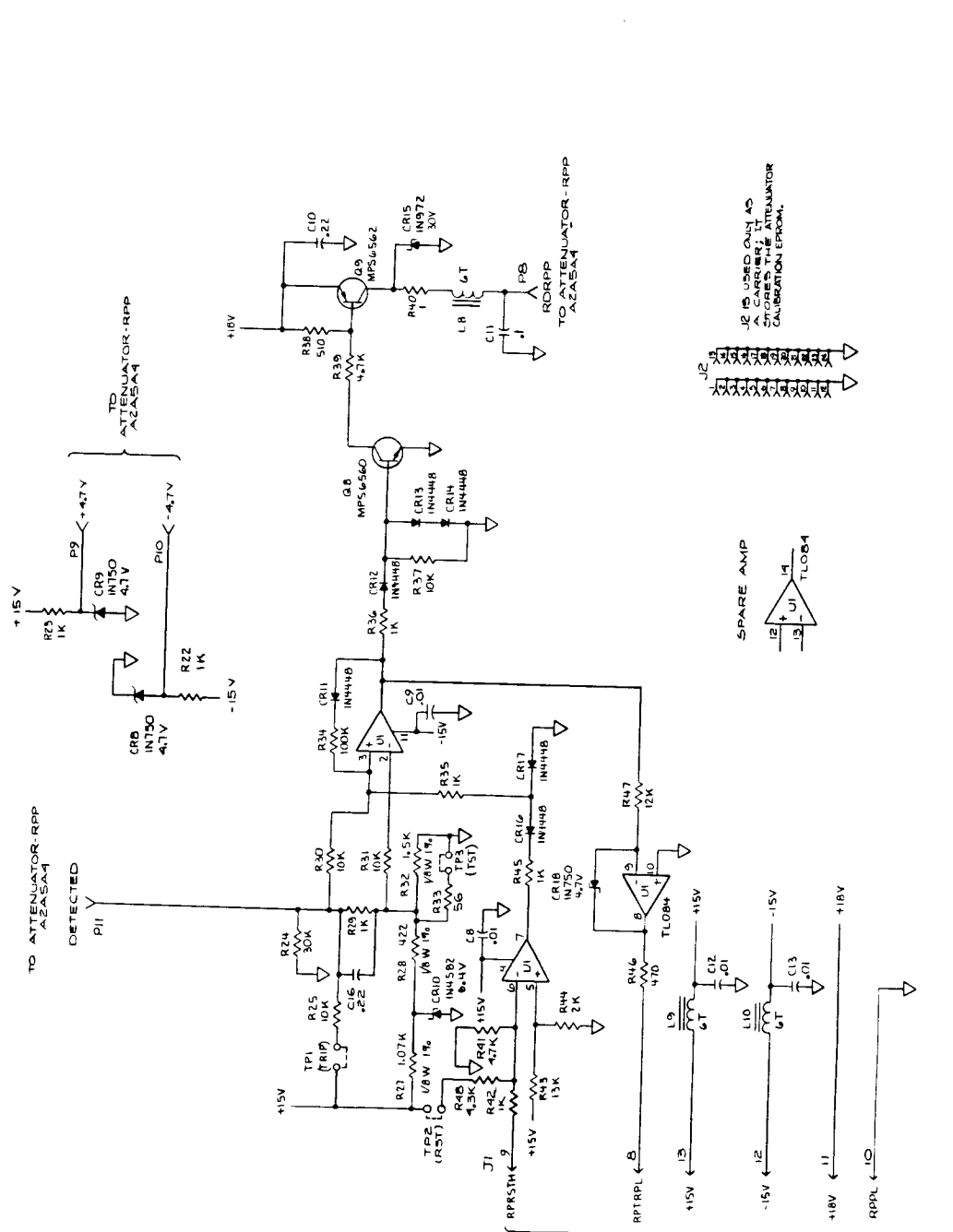

J2 IS USED ONLY AS A CARRIER; IT CHANGES THE ATTENUATOR CALIBRATION FROM:

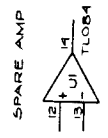

Figure 8-10. A2ASAS Relay Driver/RPP PCA (cont)

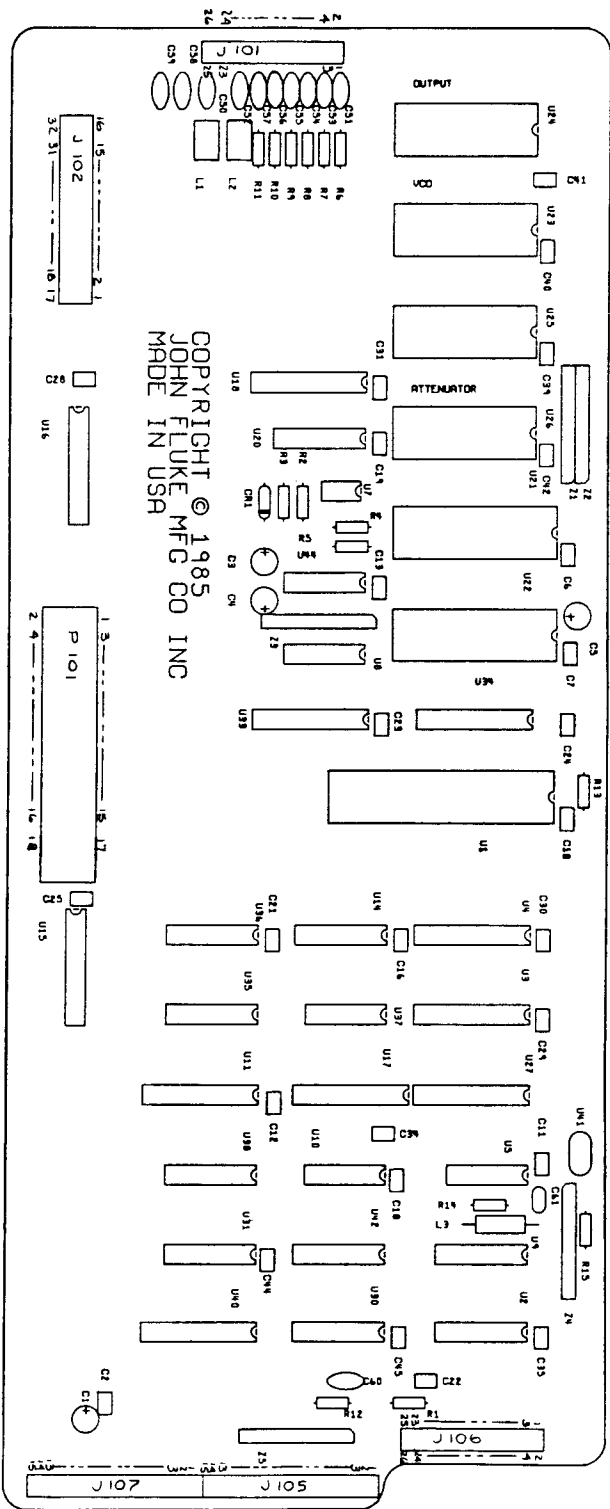

Figure 8-11. AZAT Controller PCA

SCHEMATIC DIAGRAMS

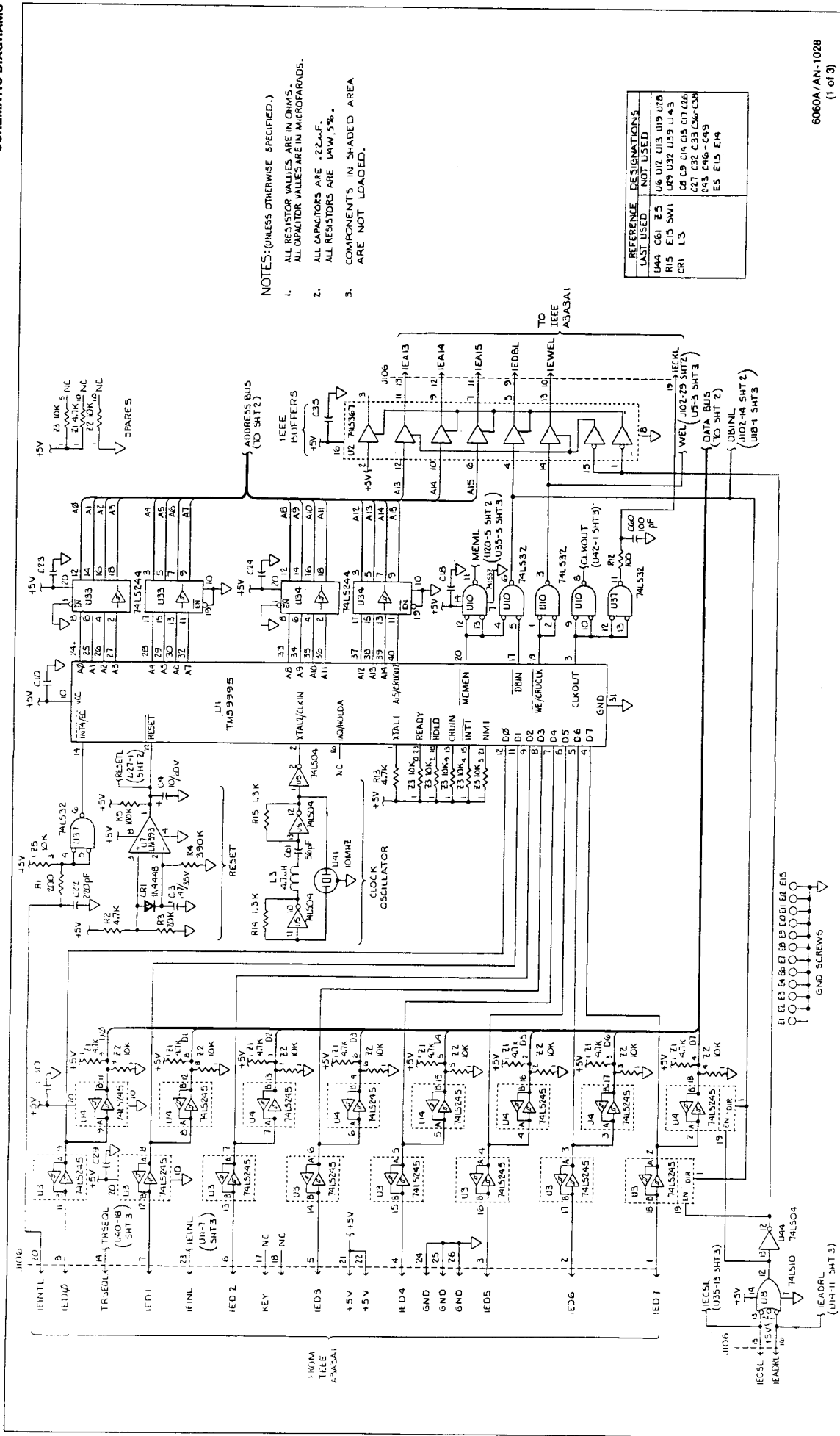
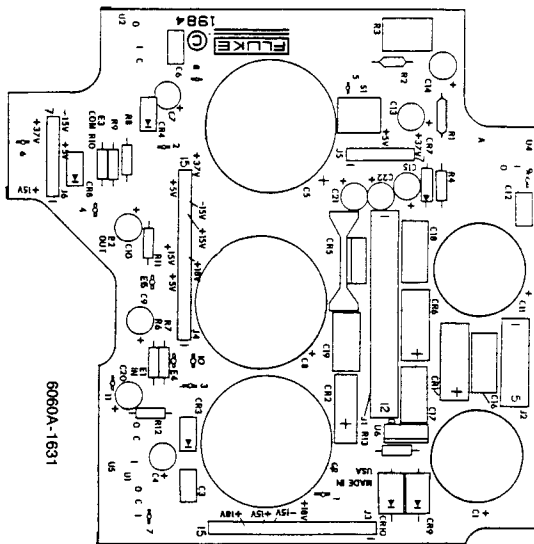

Figure 8-11. A2A7 Controller PCA (cont)

CIRCUIT 2



ASAI	REFERENCE DESIGNATIONS
LAST USED	UNUSED
A13	B5
C22	C20
C10	U6
U6	S1
S1	FP11

- NOTES: UNLESS OTHERWISE SPECIFIED.
1. ALL RESISTORS IN OHMS.
 2. ALL CAPACITANCES IN MICROFARADS.
- ⊗ RATING OF F11
1.5A WHEN AC INPUT IS 115 VAC.
1.5A WHEN AC INPUT IS 230 VAC.
- ⊕ THERMAL PROTECTOR INTERNAL TO T1.

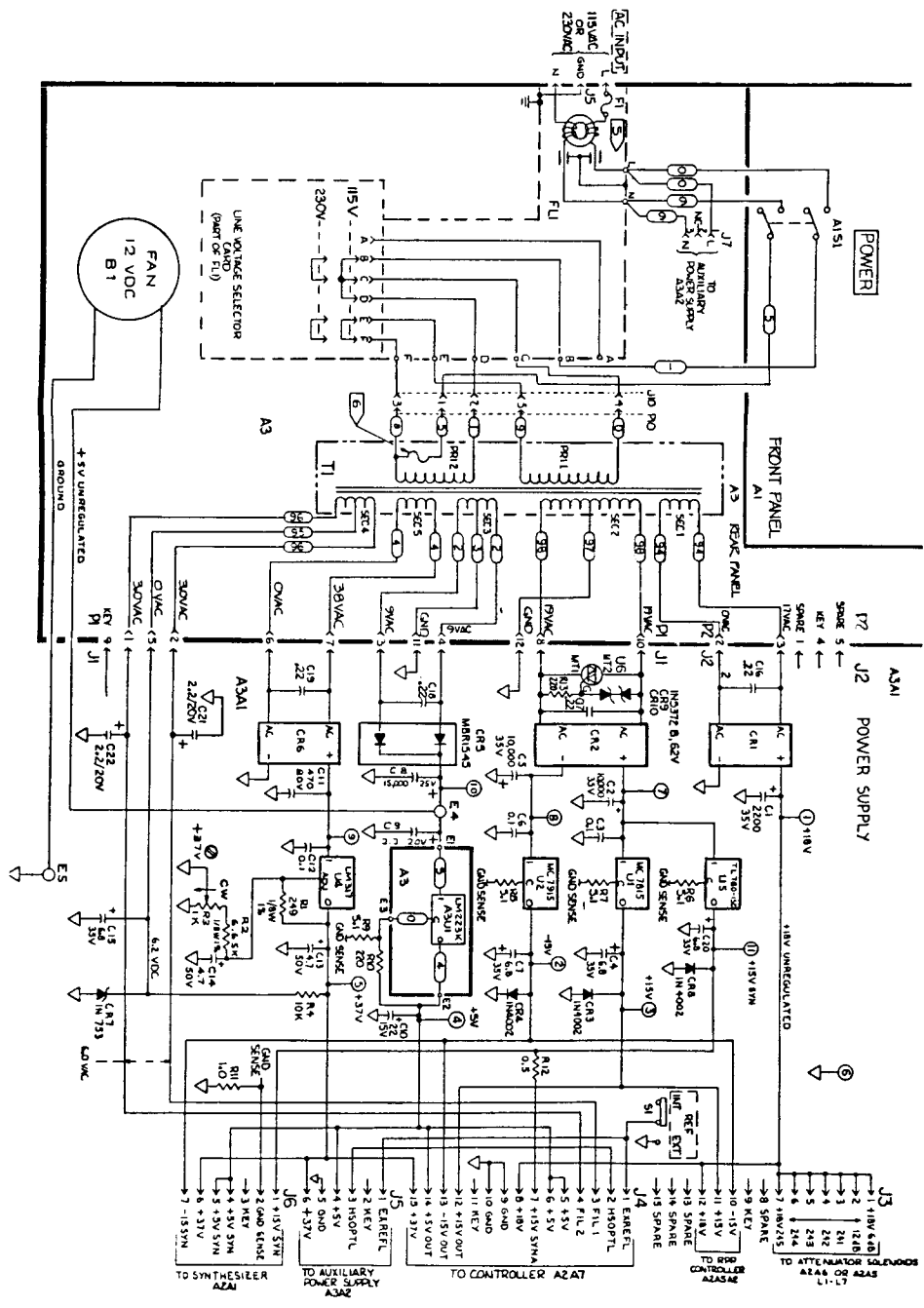

Figure 8-12. ASAI Power Supply PCA

SCHEMATIC DIAGRAMS

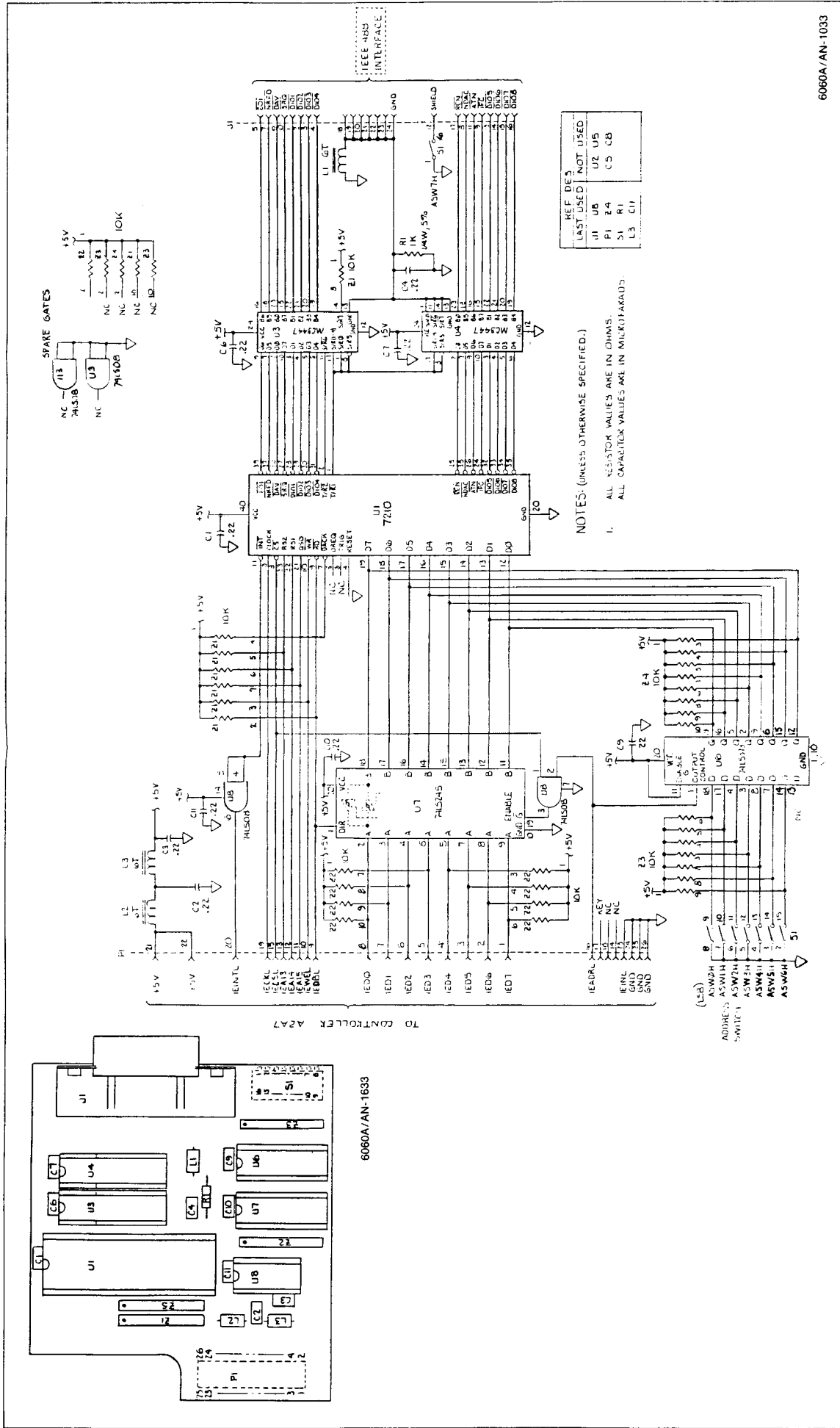
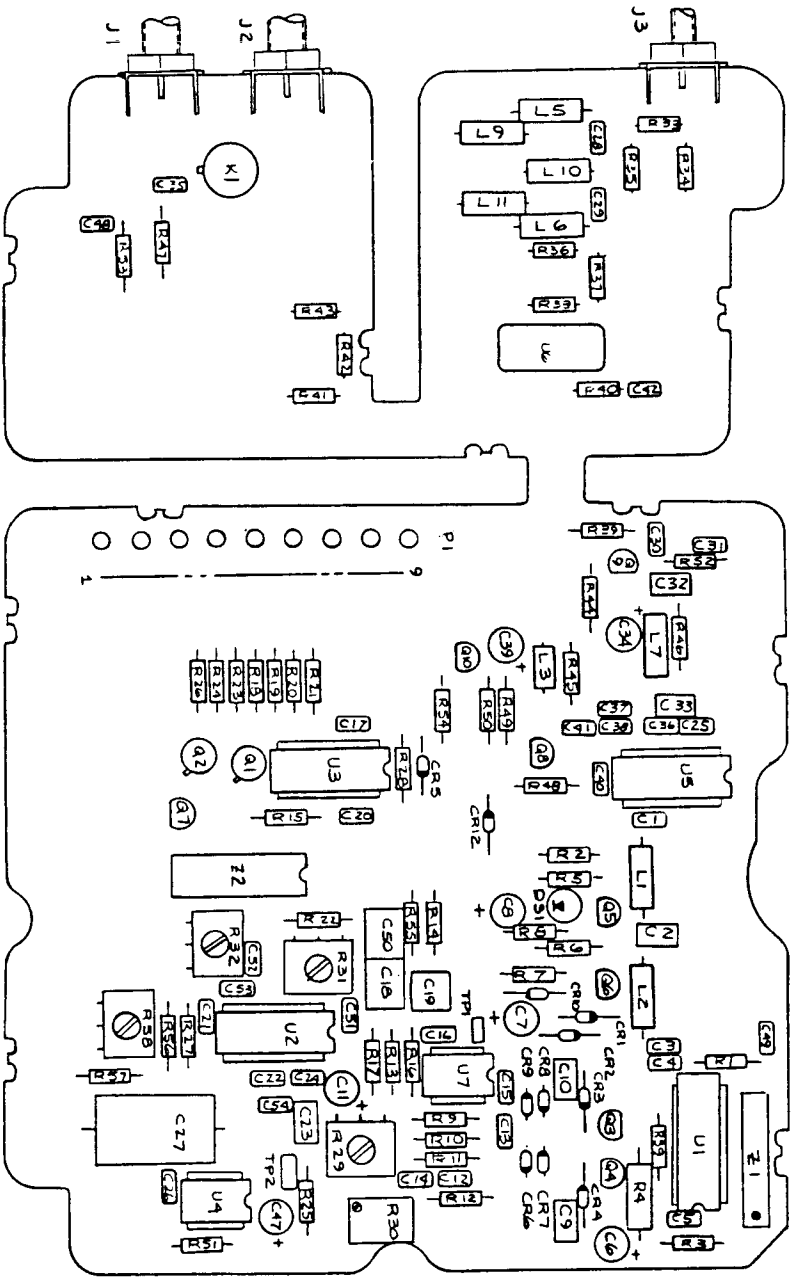

Figure 8-13. A3A3A1 IEEE-488 Interface PCA



6060A/AN-1661

Figure 8-14. A4A1 Discriminator PCA

SCHEMATIC DIAGRAMS

REFERENCE DESIGNATION	VALUE	UNIT	LAST USED
C14	0.01	μF	CR1, CR2
C15	0.01	μF	CR1, CR2
C16	0.01	μF	CR1, CR2
C17	0.01	μF	CR1, CR2
C18	0.01	μF	CR1, CR2
C19	0.01	μF	CR1, CR2
C20	0.01	μF	CR1, CR2
C21	0.01	μF	CR1, CR2
C22	0.01	μF	CR1, CR2
C23	0.01	μF	CR1, CR2
C24	0.01	μF	CR1, CR2
C25	0.01	μF	CR1, CR2
C26	0.01	μF	CR1, CR2
C27	0.01	μF	CR1, CR2
C28	0.01	μF	CR1, CR2
C29	0.01	μF	CR1, CR2
C30	0.01	μF	CR1, CR2
C31	0.01	μF	CR1, CR2
C32	0.01	μF	CR1, CR2
C33	0.01	μF	CR1, CR2
C34	0.01	μF	CR1, CR2
C35	0.01	μF	CR1, CR2
C36	0.01	μF	CR1, CR2
C37	0.01	μF	CR1, CR2
C38	0.01	μF	CR1, CR2
C39	0.01	μF	CR1, CR2
C40	0.01	μF	CR1, CR2
C41	0.01	μF	CR1, CR2
C42	0.01	μF	CR1, CR2
C43	0.01	μF	CR1, CR2
C44	0.01	μF	CR1, CR2
C45	0.01	μF	CR1, CR2
C46	0.01	μF	CR1, CR2
C47	0.01	μF	CR1, CR2
C48	0.01	μF	CR1, CR2
C49	0.01	μF	CR1, CR2
C50	0.01	μF	CR1, CR2
C51	0.01	μF	CR1, CR2
C52	0.01	μF	CR1, CR2
C53	0.01	μF	CR1, CR2
C54	0.01	μF	CR1, CR2
C55	0.01	μF	CR1, CR2
C56	0.01	μF	CR1, CR2
C57	0.01	μF	CR1, CR2
C58	0.01	μF	CR1, CR2
C59	0.01	μF	CR1, CR2
C60	0.01	μF	CR1, CR2
C61	0.01	μF	CR1, CR2
C62	0.01	μF	CR1, CR2
C63	0.01	μF	CR1, CR2
C64	0.01	μF	CR1, CR2
C65	0.01	μF	CR1, CR2
C66	0.01	μF	CR1, CR2
C67	0.01	μF	CR1, CR2
C68	0.01	μF	CR1, CR2
C69	0.01	μF	CR1, CR2
C70	0.01	μF	CR1, CR2
C71	0.01	μF	CR1, CR2
C72	0.01	μF	CR1, CR2
C73	0.01	μF	CR1, CR2
C74	0.01	μF	CR1, CR2
C75	0.01	μF	CR1, CR2
C76	0.01	μF	CR1, CR2
C77	0.01	μF	CR1, CR2
C78	0.01	μF	CR1, CR2
C79	0.01	μF	CR1, CR2
C80	0.01	μF	CR1, CR2
C81	0.01	μF	CR1, CR2
C82	0.01	μF	CR1, CR2
C83	0.01	μF	CR1, CR2
C84	0.01	μF	CR1, CR2
C85	0.01	μF	CR1, CR2
C86	0.01	μF	CR1, CR2
C87	0.01	μF	CR1, CR2
C88	0.01	μF	CR1, CR2
C89	0.01	μF	CR1, CR2
C90	0.01	μF	CR1, CR2
C91	0.01	μF	CR1, CR2
C92	0.01	μF	CR1, CR2
C93	0.01	μF	CR1, CR2
C94	0.01	μF	CR1, CR2
C95	0.01	μF	CR1, CR2
C96	0.01	μF	CR1, CR2
C97	0.01	μF	CR1, CR2
C98	0.01	μF	CR1, CR2
C99	0.01	μF	CR1, CR2
C100	0.01	μF	CR1, CR2

- NOTES - UNLESS OTHERWISE SPECIFIED:
1. ALL RESISTANCES ARE IN OHMS.
 2. ALL RESISTANCES ARE 1/4W @ 2%.
 3. ALL CAPACITANCES ARE IN MICROFARADS.
 4. ALL CAPACITANCES ARE 50V.
 5. ALL INDUCTANCES ARE IN MICROHENRIES.
 6. ALL 1% RESISTORS ARE 1/8W.

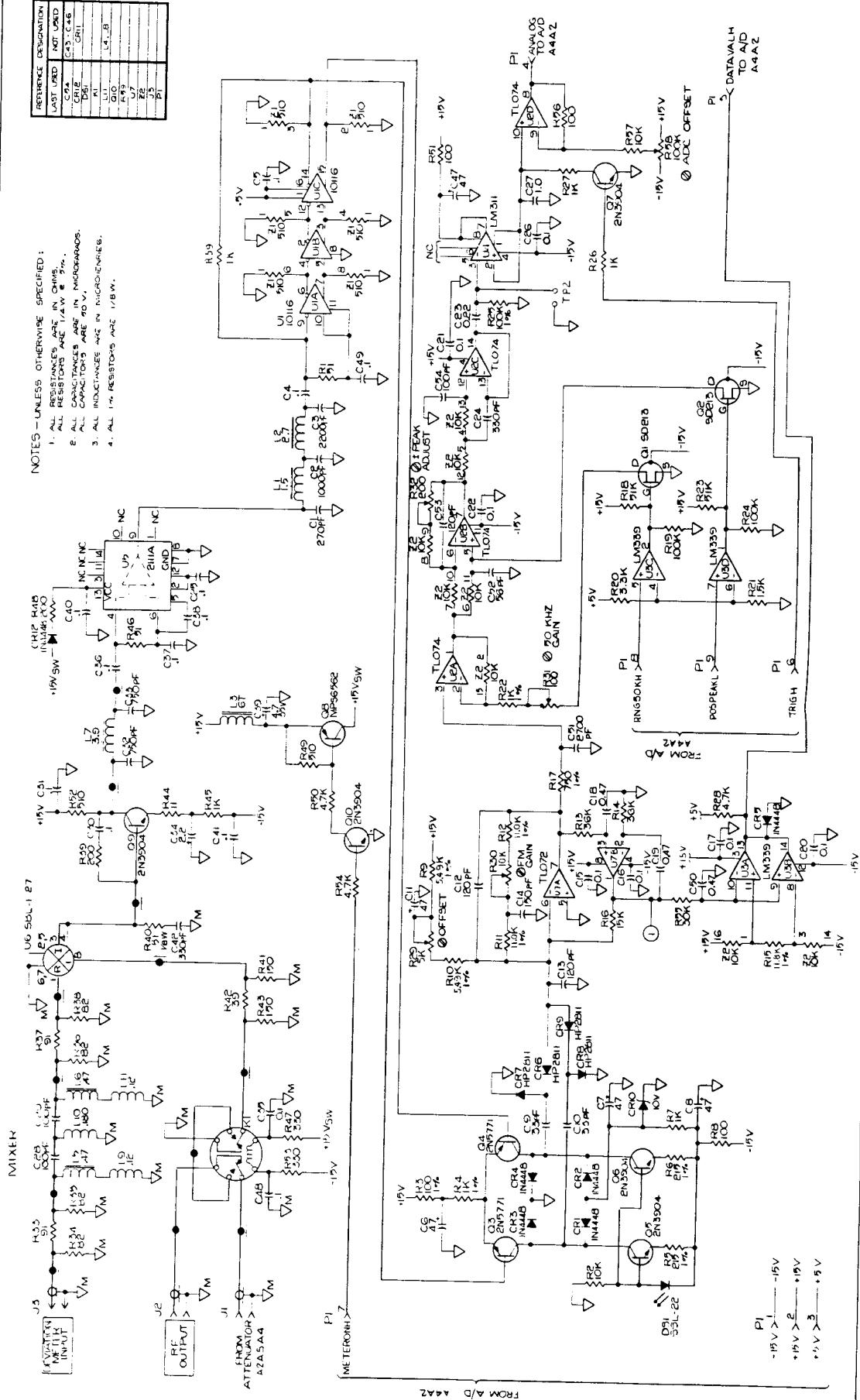
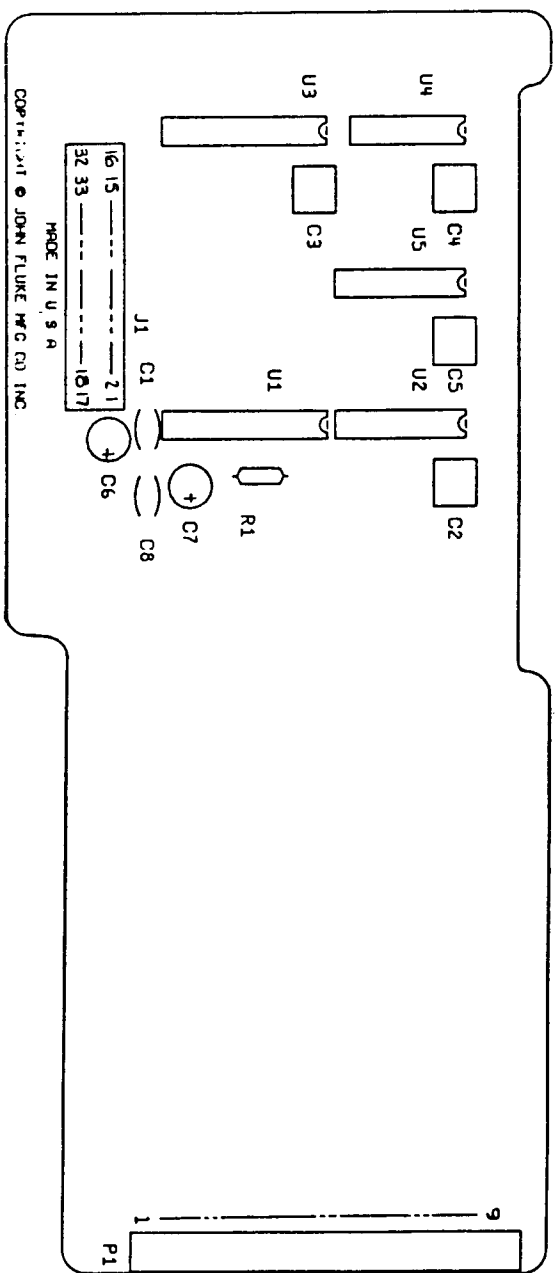

Figure 8-14. A4A1 Discriminator PCA (cont)



6060A/AN-1660

Figure 8-15. AAA2 Analog/Digital PCA

SCHEMATIC DIAGRAMS

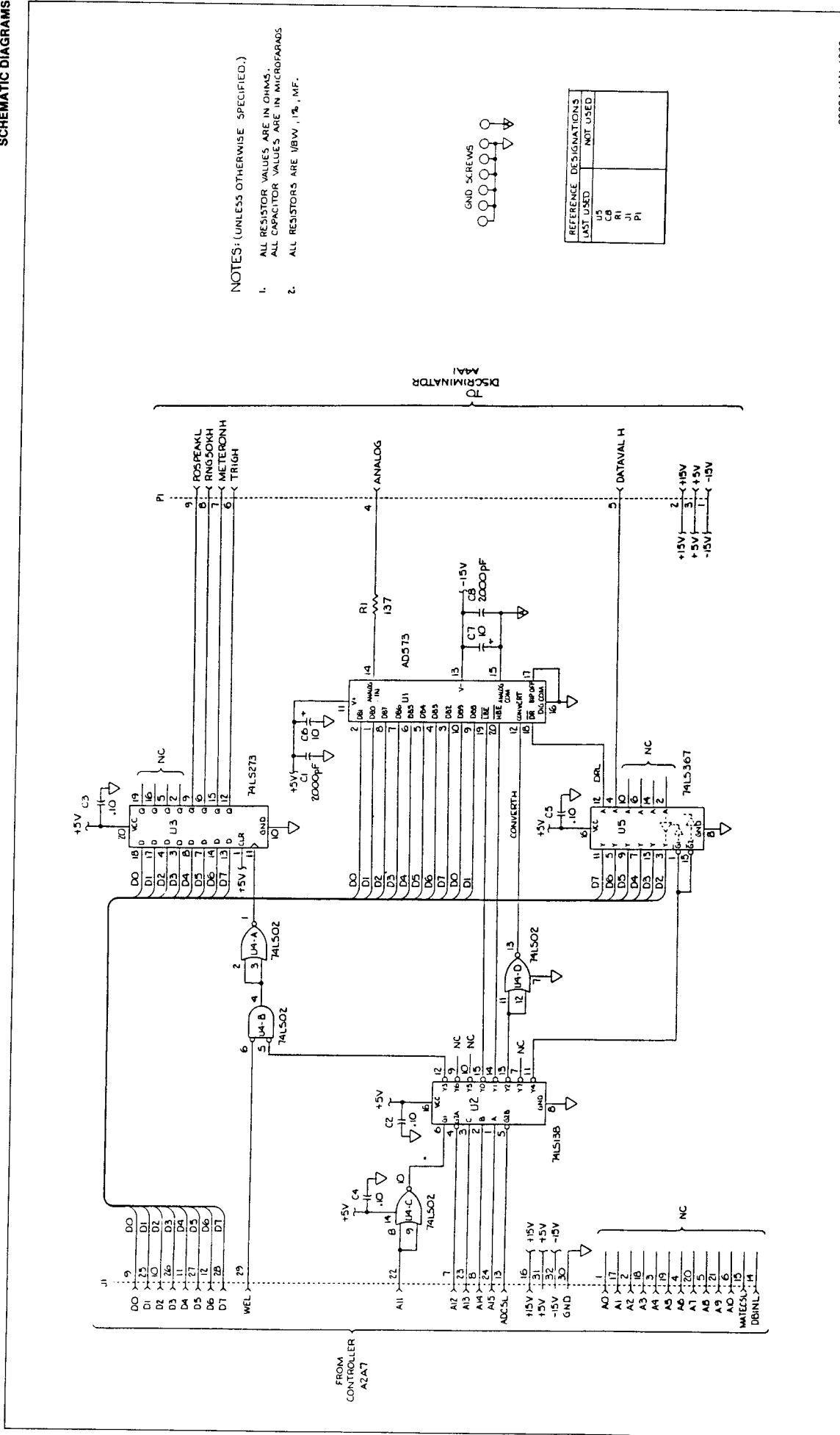

NOTES: (UNLESS OTHERWISE SPECIFIED.)

1. ALL RESISTOR VALUES ARE IN OHMS.
- ALL CAPACITOR VALUES ARE IN MICROFARADS
2. ALL RESISTORS ARE 1/8W, 1%, MF.

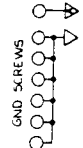

REFERENCE DESIGNATIONS	LAST USED	NOT USED
U5		
C8		
R1		
J1		
P1		

Figure 8-15. A4A2 Analog/Digital PCA (cont)

REJECTED ENTRY CODES (Press the [STATUS] key to display codes)

- 001 000 000 = FM deviation not between 0 and 500 KHz
- 002 000 000 = FM deviation Step not between 0 and 500 KHz
- 004 000 000 = AM depth not between 0 and 99%
- 010 000 000 = AM depth step not between 0 and 99%
- 020 000 000 = IEEE-488 command syntax error
- 040 000 000 = IEEE-488 input value out of range
- 200 000 000 = IEEE edit or step operation beyond allowed range
- 400 000 000 = Entry not allowed while in the meter mode
- 000 001 000 = Frequency not between 0.2 and 1050 MHz
- 000 004 000 = Frequency Step not between 0 and 1050 MHz
- 000 040 000 = Invalid memory location
- 000 100 000 = Invalid data in memory
- 000 200 000 = Special function not allowed
- 000 000 001 = Output amplitude not between 10 nV and 2V
- 000 000 002 = Insufficient resolution for units conversion
- 000 000 004 = Units conversion to volts not allowed with reference in volts
- 000 000 010 = Units conversion to dB not allowed with reference in volts
- 000 000 020 = Amplitude Step not between 0 and 166 dB or 0 and 1999V
- 000 000 040 = Units conversion of Amplitude Step not allowed
- 000 000 100 = Amplitude step and current amplitude display not in same units

UNCAL CODES (Press the [STATUS] key to display codes)

- Flashing codes (denoted by *) indicate abnormal operation or aberrated output.
- Non-flashing codes indicate operation outside specified range.
- 000 000 000 indicates no UNCAL conditions.
- 001 000 000 = FM deviation < 1 KHz
- * 002 000 000 = FM deviation > 50 KHz and freq ≤ 5 MHz
- 004 000 000 = Excess FM deviation, main or reference PLL unlocked
- 000 002 000 = Frequency < 0.4 MHz
- * 000 010 000 = Main or reference PLL unlocked
- 000 000 001 = Level vernier below calibrated range or level < -127 dBm
- 000 000 002 = Peak (AM) amplitude > +13 dBm
- * 000 000 004 = Amplitude unlevelled
- * 000 000 010 = Fixed-range level vernier at 0
- * 000 000 020 = Fixed-range level vernier at full scale
- * 000 000 040 = RPP tripped
- 000 000 100 = Level below -127 dBm
- 000 000 200 = Level correction disabled
- * 000 000 400 = RF off

SPECIAL FUNCTION OPERATION (Press the [SPCL] key, then press the 2-digit code)

The two-digit code consists of a class numeric followed by a mode numeric. The activated modes of classes 2 through 9 are shown in the FREQUENCY display field while the [SPCL] key is pressed. For example, reading from left to right, 01000201 indicates that relative amplitude, slow key-repeat-rate, and amplitude fixed-range are selected.

Code	Function	Code	Function
00	Clears all special functions	20/21	Disable/enable relative freq.
02	Initiates self test	30/31	Disable/enable relative ampli
03	Display check	40	Not used
04	Key check	50	Not used
07/08	Set/reset SRQ	60/61	Disable/enable meter mode
09	Display S/W rev & instr ID	70/71/72	Medium/fast/slow key-rep-rate
10	Display IEEE-488 address	80	Enable amplitude correction
11	Display self test results	81	Disable all level correction
12/13	Turn on/off Display	82	Disable attenuator correction
14	Initialize Memory	83-86	Program alternate 24 dB atten
15	Latch test	90/91	Disable/enable ampli fixed-rng

SELF TEST RESULTS (Press the [SPCL] [1] [1] keys to display the results)

The self test results are reported in the four display fields as follows:

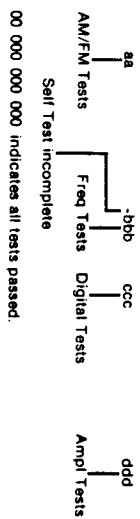

MEMORY

Instrument settings may be stored in locations 01 through 50 and later recalled. Location 98 contains the Instrument Preset State.